

# PEARL

Web: <http://www.pearl-hifi.com> #200, 2137 33 Ave, SW; Calgary, AB; T2T 1Z7

E-mail: [custserv@pearl-hifi.com](mailto:custserv@pearl-hifi.com) Ph: +. 1. 403. 607. 6633 Fx: +. 1. 403. 240. 2851

---

*Perkins Electro-Acoustic Research Laboratory.*



*Hand-Builders of Fine Music-Reproduction Equipment*

This document has been prepared as a public service and  
is intended for unrestricted distribution.

Any and all trademarks and logotypes used herein are  
the property of their owners.

Please note that the links in the PEARL logotype above are “live”  
and can be used to direct your web browser to our site or to  
open an e-mail message window addressed to ourselves.

To view our item listings on eBay, [click here](#).

## A Little Input on Audio-Output Transformers

THE PRIMARY FUNCTION of most transformers is to facilitate the transfer of power between circuits whose voltage-to-current ratios and/or DC levels are different. Transformers designed for use as impedance converters do not function in purely DC circuits, although it is sometimes necessary to allow direct current to flow through an audio transformer, such as a push-pull or single-ended coupling or output device.

An audio-output transformer is usually required to couple a high source-impedance power-amplifying stage capable of several hundred volts of swing at an output of a few hundred milliamps to a low-impedance, frequently ground-referenced load requiring a few tens of volts drive at currents of several amps.

In Watts<sub>rms</sub>, the power developed in a circuit is the product of the current flow through the circuit, in Amps<sub>rms</sub>, and the applied voltage in Volts<sub>rms</sub>. This relationship holds for DC circuits and for AC circuits where voltage and current reach their respective peak and zero values at the same instant.

In the case of an ideal (i.e. 100% efficient, no distortion, no losses, etc.) single-ended, transformer-coupled, Class A amplifier capable of delivering 32W into 8Ω, a 16.0V output forces 2.0A to flow through the 8Ω load, yielding 16.0V x 2.0A=32W of power. If the turns ratio of the transformer is 16:1, the voltage swing across the primary is 16 x 16V and the current flow is 2/16A. The power developed is 16<sup>2</sup>/8 = 32W.

If an attempt is made to force the tube output stage of this same amp to drive an 8Ω speaker directly, a tremendous reduction in the power available will be seen. The maximum current the output stage can deliver is limited to about 0.5A; as only 4.0V are required to force such a current through 8Ω, the volt/amp product yields a figure of only 2 watts!

It can be readily seen that the ratio of primary voltage to secondary voltage is 16/16<sup>2</sup>=16 while the current ratio is .125/2 = .0625.

Either of these relationships can be used to determine the *turns ratio* of the transformer, although the use of the voltage figures usually makes measurements easier. In the present case, looking from the primary to the secondary, the ratio is 16:1, i.e. for every 16 turns on the primary, there is one turn on the secondary.

The impedance reflected back to the primary side by an 8Ω load on the secondary is easily calculated: it's equal to the (turns-ratio)<sup>2</sup> x (the load impedance). Thus, an 8Ω load reflects back to the primary as 2048Ω; a 16Ω load, 4096Ω; and a 4Ω load, 1024Ω. The point here is that a transformer does not have a fixed input or output impedance as such; it is a device used to match circuits to each other in such a way that, for instance, the maximum transfer of power can take place.

An irreducible limitation is that transformers are *band-pass filters*, which, by definition, exhibit a finite usable bandwidth. The geometric center frequency<sup>†</sup> of the usable band—the *pass-band*—is determined by the design of a given transformer and is broadly defined by the intended source and load impedances used as factors in the design. Other source and load impedances can be used, provided that their ratio is made equal to the source/load impedance ratio employed in the original design; then the geometric center of the passband will simply move either up or down in frequency. As this usually occurs without serious effects, the design center values should not be taken as rigidly fixed absolutes.<sup>1</sup>

### ALAS... REALITY!

Upon leaving the world of the perfect 32W, Class A amplifier, life becomes rather more complex, and the difficult task of designing a high-power, wide-bandwidth, Class A(B) output transformer assumes its full proportions.

A tube type power-output stage can be configured in many ways: triode, fixed screen-voltage pentode/beam tetrode, swinging screen-voltage pentode/beam tetrode—ultra-linear—partially or fully cathode coupled, Class A<sub>1</sub> or A<sub>2</sub>, Class AB<sub>1</sub> or AB<sub>2</sub>, etc.<sup>2, 3, 4, 5, 6, 7</sup>

Much study of the numerous options has shown that a properly executed, ultra-linear, partially cathode-coupled, Class AB<sub>1</sub> output stage represents a well optimized, balanced solution to the various

<sup>†</sup> The geometric center frequency of any frequency band is equal to the square root of the product of the lower and upper frequencies, i.e. the geometric center of the 20Hz to 20kHz band equals the square root of 400,000, or 632.45Hz.

If a piece of frequency-response graph paper with frequency scaled logarithmically is folded in half so that the 20Hz line is laid over the 20kHz line, the crease will occur at 632Hz.

problems presented. Consequently the PEARL SC280 transformer has been specifically designed to operate in this manner. This by no means precludes its use in other output-stage configurations. The stage described presents serious design challenges; as these have been well met, the transformer will work admirably in more straightforward applications such as high idle-current class A triode stages or low idle-current, class AB<sub>1</sub>, fixed screen voltage, pentode/beam tetrode operation.

No matter the output stage configuration, good low-frequency response requires a high value of primary open circuit inductance, OCL.

A good rule is that for every 1000Ω of reflected primary impedance, the transformer should develop 70H of OCL from very low power upwards. This will yield a small-signal low-frequency -1dB point in the 3Hz region. It should be noted that the power-handling capacity of any transformer reduces to ¼ of its previous value for every halving of frequency. Thus, a device capable of a 300W output at 20Hz can meet only a 75W demand at 10Hz while at 1Hz its output capability has dwindled to a few hundred milliwatts. See Fig 1.<sup>8</sup>

While good low-frequency extension is, relatively speaking, easily accomplished, smooth, extended high-frequency performance is always difficult to achieve. The physical characteristics of the sorts of windings required for extended low- vs. extended high-frequency response are exactly opposite in nature and there exists an ultimate limit on the usable bandwidth attainable for a given output power and unit cost. If the very best of modern materials are used and no effort is spared in the precise execution of the design, the bandwidth can be extended beyond that previously considered to be practically achievable.

Among the factors to be carefully minimized are the leakage inductance,  $L_L$ , and the inter-layer and inter-winding capacitances. Due consideration must be given to the inter-winding AC potential differences, as these directly affect the net charge, hence the effective capacitance, and therefore the characteristic impedance of a given section of the winding.

Mismatches in these values cause energy reflections within the windings and result in numerous high-frequency, self-resonant modes. These in

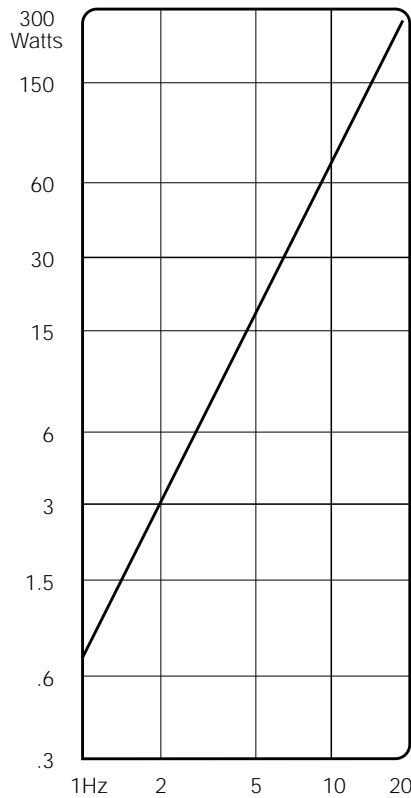


Fig. 1. The decrease of low-frequency output ability with decreasing frequency.

turn produce a rough high-frequency response with ragged phase and group-delay figures that can make the application of loop feedback a perilous undertaking.

If the amplifier is intended to operate pentode class AB, the difficulties are further compounded by the need for fantastically tight inductive coupling between the two halves of the primary—which must be accomplished with an absolute minimum of capacitive coupling.

The need for low capacitive-coupling between the half primaries must be met, as any half-primary-to-half-primary capacitance acts—with an increase in driving frequency—as a decreasing value shunt load between the opposing halves of the output stage. At high frequencies, a lowered impedance between these two points will excessively load the output tubes and adversely affect the high-frequency output at the secondary.<sup>9, 10, 11, 12, 13, 14, 15, 16, 17</sup>

In a class A amplifier, current always flows in both halves of the primary, whereas pentode class AB operation results in the cessation of current flow in one or the other half-primary as the output stage makes the transition from class A into class B. Because the two half-primaries are never perfectly flux-coupled to each other, a back EMF spike is generated in the half-primary-to-half-primary  $L_L$  whenever current flow is abruptly terminated in either half primary.<sup>†</sup> This voltage acts to stimulate a resonant circuit consisting of the half-primary to half-primary  $L_L$  and some portion of the various capacitances present.

This causes the appearance of a pernicious form of *notch distortion*<sup>††</sup>, resulting in upper-frequency common-mode signals that can partially couple into the load. As the feedback network samples the output from the amplifier at the point of interface with the load, this error voltage finds its way, via the feedback loop, throughout the entire amplifier.

Unfortunately, feedback can do nothing to reduce this particular distortion form. The circuit exhibiting the distortion being *downstream* from the output tube(s) biased into cutoff, feedback can only serve to aggravate the problem.<sup>18, 19, 20</sup>

<sup>†</sup> Triode and UL connections are not nearly as problematic in this respect as fixed-screen-voltage pentode/beam tetrode connections.

<sup>††</sup> Not to be confused with the *crossover distortion* exhibited by improperly biased solid-state amplifiers

Two of the cures for this situation are:

- the—very difficult—reduction of  $L_L$  to vanishingly low levels
- the use of the McIntosh unity-coupled circuit

In their early papers McIntosh suggested that a ratio of OCL to half-primary-to-half-primary  $L_L$  of 80,000:1 would be required to effectively eliminate the Class B notch-distortion problem. In the PEARL SC280 transformer this ratio is 40,000:1.

Any push-pull amplifier must show extreme precision with regard to the balance of its push and pull halves.<sup>2, 21, 22, 23</sup> Without such balance, common-mode error voltages are generated that cannot be extracted by any known corrective measure.<sup>24</sup>

Additionally, such voltages can be generated through any of the following actions:

- capacitive coupling of the AC line to the core of the power transformer, to the chassis, and hence to signal ground
- poor noise/ripple rejection or high internal impedance in the various power supplies
- improper phase-inverter stage AC balance<sup>25</sup>
- unbalanced gains in the push and pull halves of the driver and output stages
- tube-aging and thermal-drift effects<sup>26</sup>
- AC and DC winding imbalances and, if the output transformer is intended for Class B operation, high half-primary-to-half-primary leakage inductance  $L_L$ .

The amplifier design presently in progress in our

lab is one in which all of the factors above and numerous others have been very carefully considered.

No matter how admirable the standard set by the circuitry preceding the output transformer, much performance can be lost if the transformer has not been designed for excellent high-frequency common-mode performance. Such a specification demands extraordinary AC and DC balance within the windings, and these have been achieved in the SC280 transformer. See the *Specifications* section for more details.

In summary, the present transformer is the fruit of a thorough-going and often arduous research and development effort spanning a four year period.

Much study of the prior art revealed many fascinating aspects of the work done during the heyday-era of the vacuum tube. We have been able to “look over the shoulder” of some of the most talented designers of the day.

In this work we have used what we consider to be the very best ideas expounded by numerous workers and writers in the field. To this admixture of knowledge and experience we have added our own insights. Our finished product incorporates a host of design and construction features never before simultaneously embodied in any output transformer of which we have knowledge.

## NOTES ON THE SPECIFICATIONS

The transformer is spec'd overleaf in just one of many possible configurations. The device can be wound to meet almost any requirement, based on the clear understanding that all the electrical parameters co-mingle: one cannot be changed without affecting most of the others.

---

## REFERENCES

- 1 Using Audio Transformers, Herbert Ravenswood, *Radio-Electronics*, April 1960
- 2 A Multi-Loop Self-Balancing Amplifier, J.R. Macdonald, *I.R.E. Transactions on Audio*, July-August 1955
- 3 Class-A Push-Pull Amplifier Theory, H.L. Krauss, *Proc. I.R.E.*, January 1948
- 4 New 50-Watt Amplifier Circuit, F.H. McIntosh & G.G. Gow, *Audio Engineering*, December 1949
- 5 Realistic Audio Engineering Philosophy, N.H. Crowhurst, *Audio Engineering*, October 1950
- 6 Ultra-Linear Amplifiers, F. Langford-Smith & A.R. Chesterman, *Radioelectronics*, May, June, July 1955
- 7 Amplifiers And Superlatives, D.T.N. Williamson & P.J. Walker, *Wireless World*, September 1952
- 8 Puzzled About Transformers, N.H. Crowhurst, *Radio-Electronics*, December 1960
- 9 Output Transformers, James Moir, *Audio*, February & March, 1960
- 10 Design of the Output Transformer, R.C. Hitchcock & W.O. Osborn, *Electronics*, November 1930
- 11 How Good is an Audio Transformer? N.H. Crowhurst, *Audio Engineering*, March 1952
- 12 Measuring Up an Audio Transformer, N.H. Crowhurst, *Audio Engineering*, November 1952
- 13 Audio Transformer Design, N.H. Crowhurst, *Audio Engineering*, February 1953
- 14 Output Transformer Design, N.H. Crowhurst, *Audio*, September 1956
- 15 Audio Transformers CAN Be Good, N.H. Crowhurst, *Audio*, May 1956
- 16 Leakage Inductance, N.H. Crowhurst, *Electronic Engineering*, April 1949
- 17 Winding Capacitance, N.H. Crowhurst, *Electronic Engineering*, November 1949
- 18 Quasi-Transients in Class-B Audio-Frequency Push-Pull Amplifiers, A. Pen-Tung Sah, *Proc. I.R.E.*, November 1936
- 19 The Distortion Resulting from the Use of Center-Tapped Transformers in a Class-B Power Amplifier, R.G. De Buda, *I.R.E. Transactions on Audio*, July-August 1960
- 20 Extended Class-A Audio, H.T. Sterling, *Electronics*, May 1951
- 21 Push-Pull Balance, W.T. Cocking, *Wireless World*, November 1947
- 22 Balanced Amplifiers, F.F. Offner, *Proc. I.R.E.*, Waves and Electrons Section, March 1947
- 23 Push-Pull R/C-Coupled Amplifiers, F.F. Offner, *Review of Scientific Instruments*, January 1937
- 24 Understanding Common-Mode Signals, R.N. Marsh, *Audio*, February 1988
- 25 Distortion & Phase-Splitter Unbalance in Push-Pull Amplifiers, N. Sokal, *Radio & TV News*, issue unknown (Copies are available from PEARL)
- 26 Balanced Output Amplifiers of Highly Accurate and Stable Balance, E.M.I. Laboratories, *Electronic Engineering*, June 1946

# The PEARL 280 Watt, Class AB Audio-Output Transformer

## Basic Specifications

(as of 09/96, subject to improvement without notice)

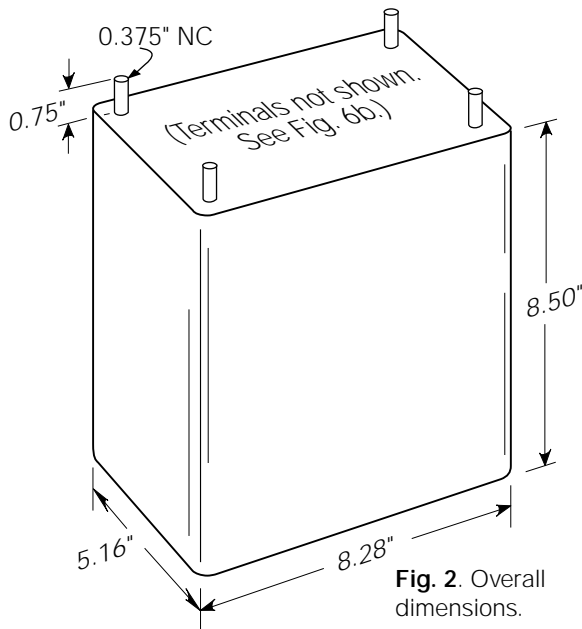


Fig. 2. Overall dimensions.

**Output power at 20Hz:** 280W into 4/8Ω.  
**Primary impedance:** 1040Ω, ct. Others available.  
**Secondary impedance:** 4/8Ω, ct.  
**Ultra-linear winding:** 30% pri turns, ct. Others available.  
**Tertiary f/b winding:** 200% sec turns, ct. Others available.  
**Turns ratio; pri. to sec:** 15.8/11.2:1. Others available.  
**Square-wave response:** See Fig. 3.  
**Frequency response:** See Fig. 4.  
**Primary inductance:** 70H @ 1W delivered into 8Ω  
**Tolerable DC-unbalance;** 10mA  
**Leakage inductance:** 685μH, pri. to sec., referred to pri. 2750μH, ½ primary to ½ primary.

**Capacitances:**  
 Pri. to sec: 6000pF  
 ½ pri. to ½ pri: 1500pF  
**DC balance:** From the center-tap to either end, any winding's  $R_{dc}$  is within 0.1%. The 100kHz frequency response from any half-section, 'A' to any other section is within .5dB of that from the the other half-section, 'B', to the same section.†

**AC balance:**  
**First resonance:** 190kHz.  
**Rise time:** 1.3μSec.  
**Winding configuration:** Astatic, interleaved, cross-coupled.

**Winding DC resistances:**  
 Primary: 18Ω plate-to-plate.  
 Secondary: 0.13Ω load-to-load.  
 Screen: 34Ω screen-to-screen.  
 Tertiary: 8.8Ω end-to-end.  
**Winding rms current capacity @ 800 circular mils/amp:**  
 Primary: 800 mA (400mA per ½ primary).  
 Secondary: 12A. (= 1152W<sub>rms</sub> into 8Ω)  
 Screen: 250mA (125mA per ½ screen).  
 Tertiary: 250mA (125mA per ½ tertiary).  
**Interlayer insulation:** Low-loss, low dielectric constant.

**Insulation Voltage Rating:**  
 Primary to secondary 1500V  
 Primary to screen 1000V  
 Primary to tertiary 1500V  
 Higher voltages are possible but at reduced bandwidth

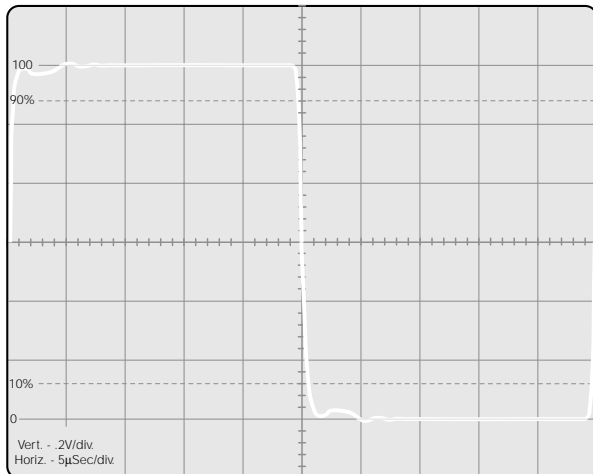


Fig. 3. 20kHz. Square-wave response @ 1.5 watts output into an 8Ω resistor from a 600Ω push-pull source.

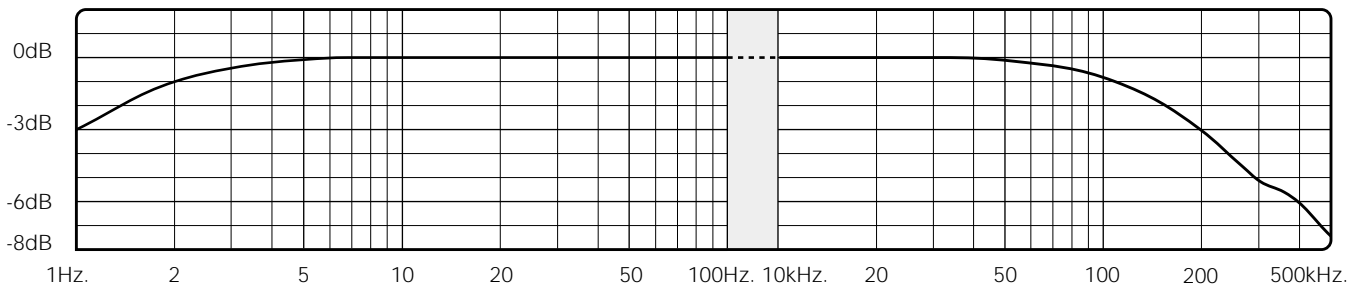


Fig. 4. 1.5 watt, primary-to-secondary frequency response from a 600Ω push-pull source into an 8Ω resistor.

**Impregnation:** High-temperature, vacuum drying, followed by vacuum/ pressure, microcrystalline-wax impregnation.

**Potting:** Microcrystalline wax

**Core type:** C-core; 4 mil, Silectron (3% Si.)

**Core power-rating at 16kG:** 280W.

20Hz: In excess of 2500W.

60Hz: Deep drawn, aluminum can.

**Enclosure:** Textured, black powder-coat.

**Finish:**

**Termination:** Secondary: leads come directly off the windings. All others: 21 AWG Polythermaleze insulated, Ohno Continuously Cast, 99.99%-pure (4-9s) copper.

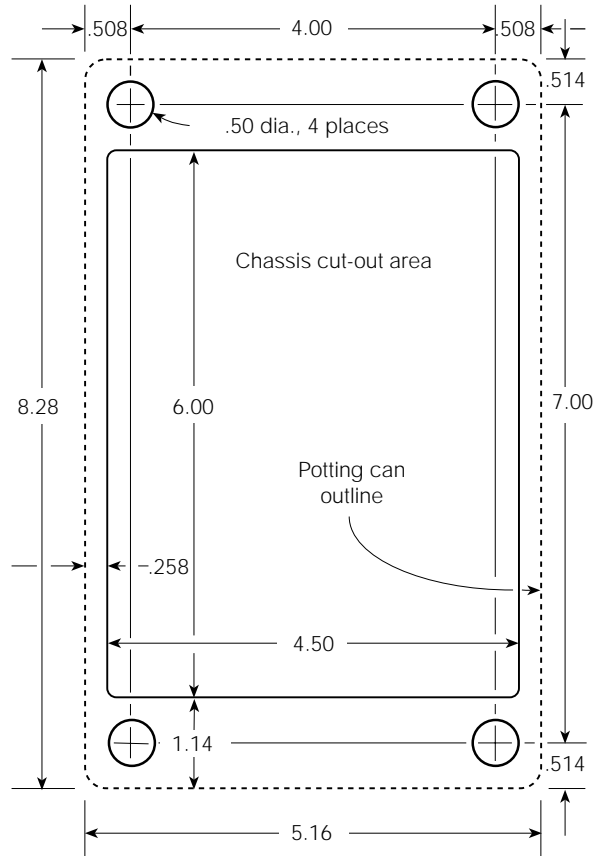
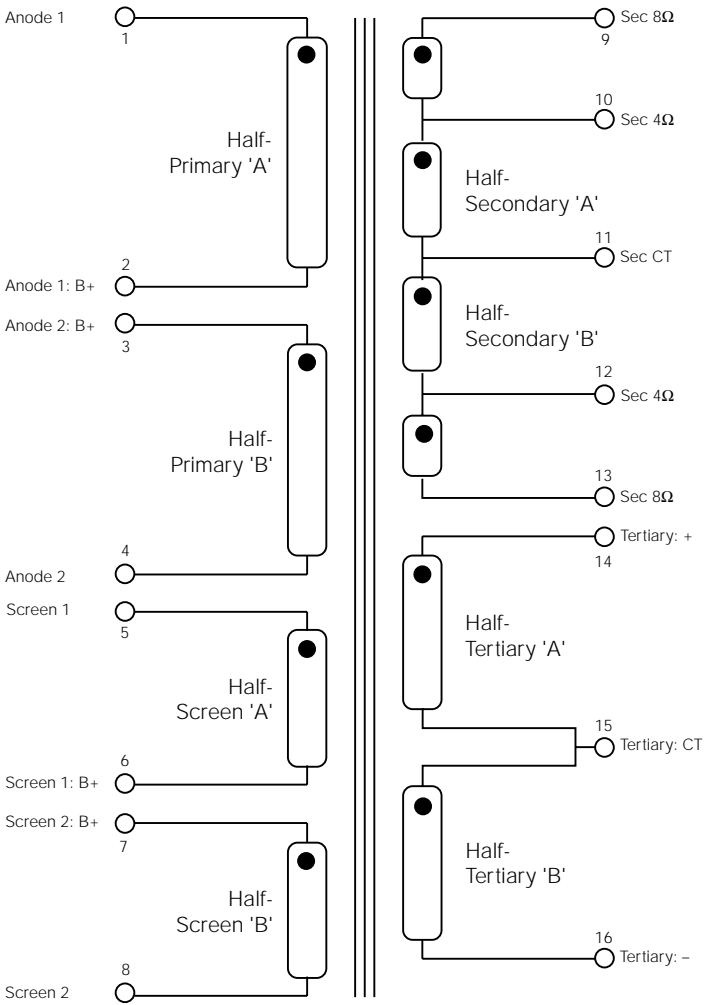
**Dimensions:** 85"H x 8.28"W x 5.16"D. See Fig. 2.

**Mounting:** 4 aluminum studs protrude from the bottom of the can.

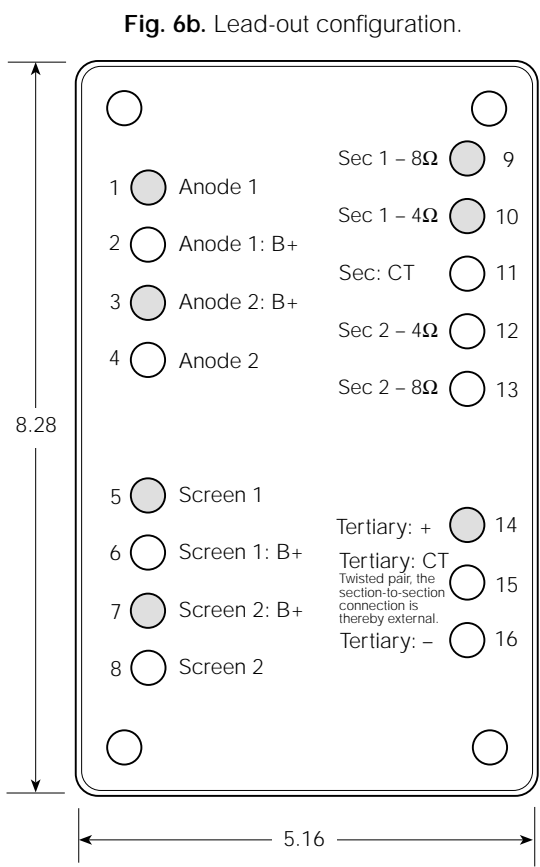
**Weight:** 38 pounds, 17.3 kgs.

†For example, the response from half-primary 'A' to half-secondary 'B' is within .5dB at 100kHz of that from the other half-primary 'B' to either half-secondary 'A' or half-secondary 'B'. The primary and secondary center taps must be connected together and tied to the common of the measuring system used.

**Fig. 5.** Transformer schematic & winding polarities.

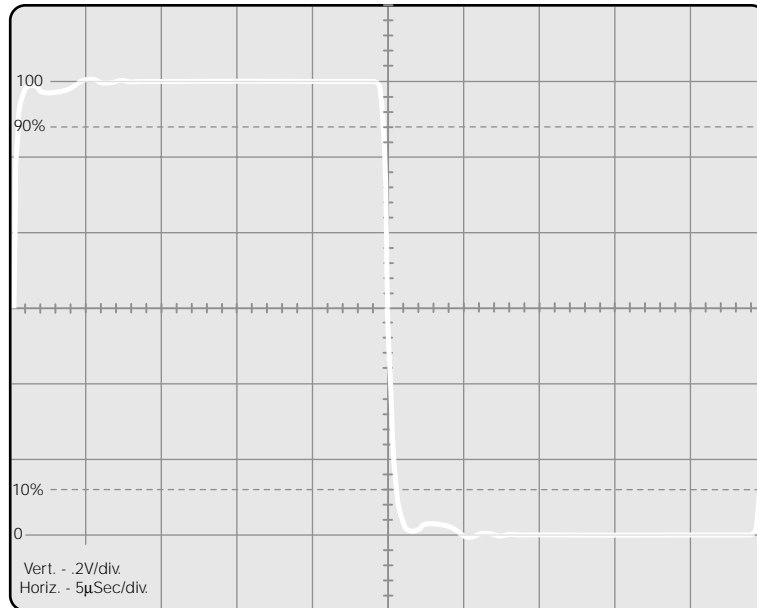


**Fig. 6a.** Chassis cut-out.



**Fig. 6b.** Lead-out configuration.

## Short-form Data: SC 280.2 Output Transformer



20kHz. square wave into a 6Ω resistor from a push-pull 600Ω source.

- A Tektronix FG504 function generator driving a purpose-built, precision phase-splitter energized a pair of HP 467 10W, wide-band, low-distortion lab amplifiers. These provided the high-accuracy push-pull signal required to correctly drive the primary. The square wave rise-time from the FG504 to the 467s was limited to 100nS. To mimic the 1000Ω  $R_p$  of 4 pairs of triode operated, push-pull, parallel-connected KT90s, 250Ω resistors were connected in series with the output of each 467. The secondary load was 8Ω connected across the full winding.
- The output was measured differentially across the centre-tapped secondary using a Tektronix 5113 mainframe oscilloscope with a 5A18N vertical plug-in set to the *Invert Ch.2/Add Ch.1-Ch.2* mode. The time base used was a 5B10N.
- All signal-commons were tied together, ie. the primary centre tap, the secondary centre tap, the common from the push-pull lab-amp pair and the grounds from the oscilloscope probes.
- The horizontal scale is 5µsec./div while the vertical scale is .2V/div.
- The rise/fall time—measured from the 10% line to the 90% line—is 1.3µsec.
- The frequency response is -1dB at 2Hz. and 120kHz. at ½ W into 8Ω.
- The primary resonance is approx 190kHz., the primary-to-secondary leakage inductance—referred to the primary—is 685µH, the half-primary to half-primary leakage inductance is 2750µH.
- *For MacNerds only:* Photo taken with a Tektronix C-50 'scope camera and converted to line art using a hyper-thyroid Mac IIfx juiced to run at 50Mhz into 20 megs of RAM and SCSI-accelerated by an FWB Jackhammer. Scans were taken with a Microtek 600 dpi grey-scale scanner, processed in Adobe Photoshop 2.5 and Aldus FreeHand 4.0. Each *Audio Note* is printed on an QMS 1725, high speed, duplexing laserwriter equipped with a dedicated 80 meg hard drive. The page layout has been done with Quark XPress 3.31.

## Update to Audio Note 2.1

### The Regulated-Screen Ultra-Linear Output Stage

FURTHER STUDY OF THE PROBLEMS relating to transformer-coupled, tube-type, audio-power-output stages has yielded some interesting insights. While a detailed paper will have to await time to write our Audio Note 17; *Triode vs. Pentode, The Grass is Greener in the Middle*; it is useful to present an overview here. Ultra-linear operation of the output stage has long been the subject of controversy and some of the reasons for this have recently become apparent to me.

The basic operation of such stages has been investigated in a very thorough manner by several researchers, most notably Herbert Keroes and David Hafler early in the 1950s and by F. Langford-Smith & A.R. Chesterman<sup>6</sup> a few years later. Broadly speaking, the UL stage has been shown to exhibit lower total harmonic distortion than either triode or fixed-screen pentode/beam tetrode<sup>†</sup> operation, very nearly the power gain of the pentode configuration and much lower, more triode-like, source impedance. While it would seem like an ideal solution to many problems, few designers have availed themselves of its benefits. Fixed screen, pentode operation remains the most common output stage configuration despite its considerable disadvantages, particularly when driven into Class B operation.

The sound of UL stages has often been described as somewhat soft, veiled and lacking in dynamics. As all of these descriptions invoke visions of poor power supply regulation it was decided to consider this pos-

sibility. It is well known that pentode operation benefits greatly from good regulation of the screen supply and only rarely does one see a modern design in which this supply isn't regulated. If a pentode is operated with its control grid-to-cathode voltage fixed and with its screen tied to an unvarying DC source, variations in plate voltage will cause only slight changes in plate current. If, however, the plate voltage is fixed and the screen voltage is varied, large changes in plate current will be observed. It follows that if the screens are energized from the usually unregulated plate supply in a power amplifier, any variation in this voltage will cause a variation in plate current. See Figs. 1a & 1b. Due to the usually considerable internal impedance of an unregulated supply of any sort, changes in current flow through such a supply will cause the voltage dropped across its internal impedance to either increase or decrease. This causes variations in the available output voltage as an inverse function of the current demanded from the supply. The greater the need for current, the lower the voltage available to force that same current through the load; with a diminution in current flow, the available voltage increases. This results in the dynamic compression of a music signal as follows; increasing signal voltage demands increased current flow through the power supply, causing increased voltage drop across the supply's internal impedance, resulting in lowered available voltage at the output of the supply. Lowered supply voltage means lowered screen voltage means lowered plate current means lowered output power. In other words, dynamic compression is taking place by means of the situation where the amplifier's output voltage decreases under load, due to lowered screen voltage, and increases with diminishing output, due to increasing screen voltage.

If the output stage is connected in a conventional UL manner, with the screens deriving their DC polarization from taps on the primary of the output transformer, the mechanism of dynamic compression just described is at work. The problem with conventionally wound and tapped UL output transformers is that, short of regulation of the main B+, there is no

<sup>†</sup>The terms *pentode*, *tetrode*, *beam-pentode* and *beam-tetrode* are often used interchangeably to describe the devices used in the output stages of tube amplifiers. This can be a rather confusing state of affairs as these are *different* items. Because only a handful of beam-pentodes have ever been designed, this configuration won't be further described.

Any tube designed for audio output service that uses a screen grid must embody some method of controlling secondary emission. Three-grid pentodes and two-grid beam tetrodes both suppress secondary emission from the plate by the creation of a near-zero-potential region between the screen grid and the plate. Tetrodes used for RF amplification aren't generally designed to suppress secondary emission but work around the problem by keeping the plate voltage well above the screen potential although this results in a considerable loss in circuit efficiency.

Providing it's not a triode and in the absence of the exact details of the internal construction of a given audio-output tube, the best way to describe it is as a *pentode/beam-tetrode*. This being rather a mouthful, I usually abbreviate to simply, *pentode*.

way to stabilize the DC potential on the screens. Even if such regulation was implemented, slight imperfections in the regulator's action would still act on the screens and hence, detrimentally on the music. Consequently, the SC280 transformer has been re-designed to include a separate, *unity-coupled* screen winding that allows the implementation of a dedicated soft-starting, regulated screen supply. This allows different voltages to be impressed upon the plate and screen making it possible to recoup the loss in power when going from pentode to ultra-linear by increasing the UL plate voltage to yield greater available swings in plate voltage and hence greater power.

Additionally, the leakage inductance between the two sections of each half-primary created by a screen tap is always high. With correct positioning, a separate screen winding can reduce this detrimental loss of coupling to nearly zero.

In terms of secondary plate-emission, UL operation is not well optimized with the plate and screen energized from the same DC potential. By carefully balancing the plate and screen potentials and the screen-feedback ratio further benefits can be obtained.

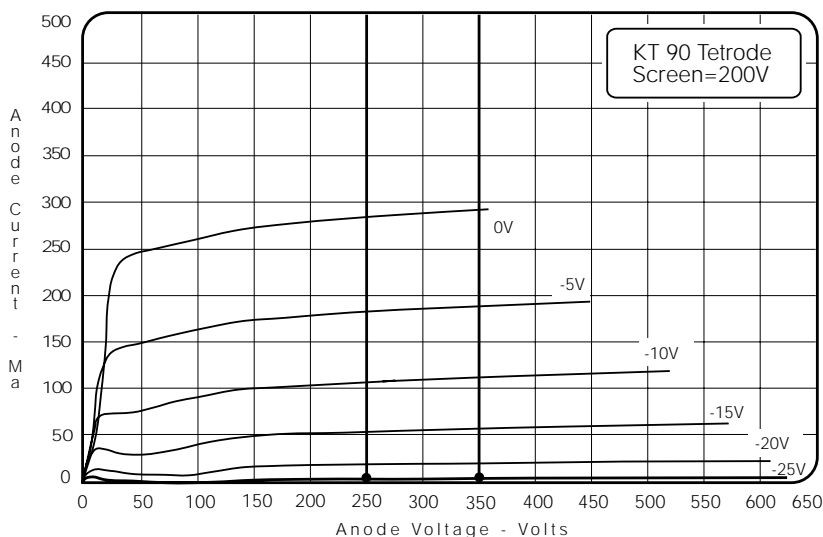
### MORE GOOD NEWS

Regarding the previously mentioned difficulties with Class A, fixed-screen, pentode operation and the notch distortion problem created thereby, it can be shown that triode and UL stages do not suffer from this problem to any great extent. With a transformer-coupled, push-pull output stage the action of a tube being turned on causes its plate voltage to decrease, ie. its plate becomes less positive than the B+ supply. Due to the *autotransformer action* of the output transformer, the opposing plate becomes *more* positive than the B+ supply. As a result, there can be a peak-to-peak AC potential difference of nearly twice the B+ voltage between opposing plates at full output. To repeat an earlier statement; for a given control-grid-to-cathode voltage, pentode plate current is essentially a function of screen voltage. In other words, if a pentode is biased into cut-off by sufficiently negative control grid-to-

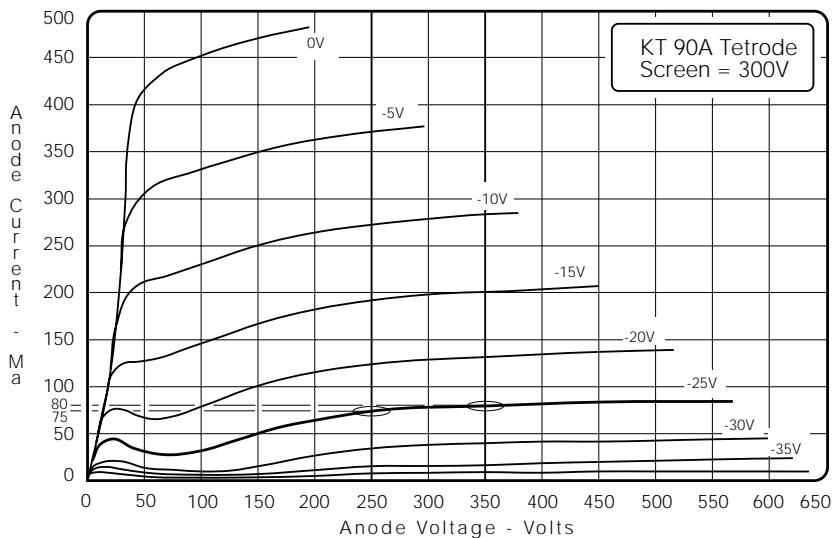
cathode voltage, no sustainable amount of increase in plate potential will cause significant current flow to resume. With its high voltage gain, sufficient negative control-grid-drive will abruptly terminate current flow through one half of the pentode configured push-pull output stage.

The triode, with its lower voltage gain, does not exhibit this effect as plate current, for a given grid-to-cathode voltage, is very much a function of plate

**Figs. 1a & 1b.** Plate current vs. plate voltage for two different screen voltages is shown for the KT90 beam tetrode.



**Fig. 1a.** Observe that there is only a slight change in plate current when the plate voltage is increased from 250V to 350V with a negative bias—grid to cathode voltage—of -25V on the control grid. Also note the plate current at just a few mA.



**Fig. 1b.** Note the increase in plate current due to the increase in screen voltage, from +200V to +300V. The -25V bias line is highlighted for ease of comparison with Fig.1a. When the plate voltage is increased from 250V to 350V the plate current increases less than 7%, from 75mA to 80mA. In both 1a & 1b observe the abruptness with which plate current drops to zero (cut-off) with increasingly negative control grid voltage.

potential. For a given plate voltage, the control grid can be made sufficiently negative to cut-off plate current flow. However current will flow once again with an increase in plate voltage and such an increase occurs as a natural consequence of the autotransformer action of the output transformer. The greater-than-B+ plate voltage induced thereby acts to keep current flowing through the tube being turned off despite increasingly negative control grid drive. See Fig. 2.

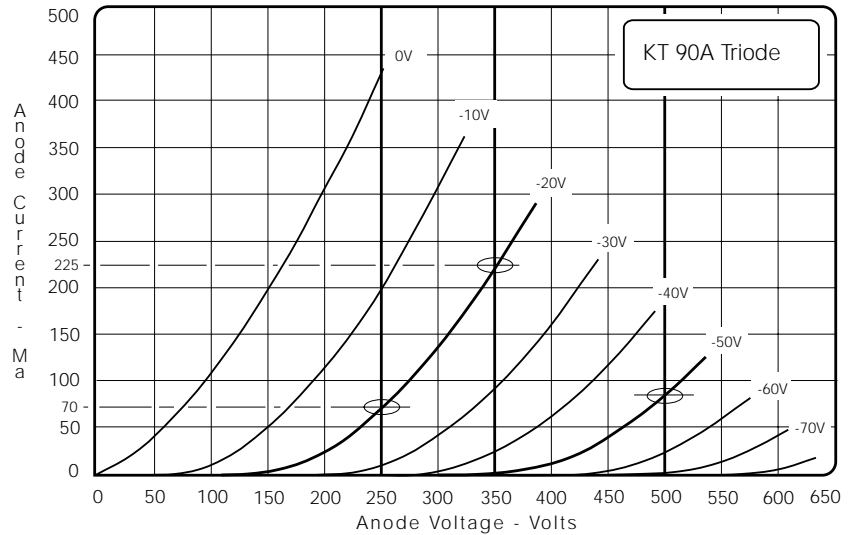
As it is the *abrupt* cessation of current flow in a half-primary that sets its leakage inductance into resonance with its stray capacitance, it can be seen that if this sudden switching action can be alleviated or eliminated so can the notch-distortion problem. Being that this distortion is more-or-less a given with pentode operation—in that feedback has no beneficial effect and in fact aggravates the situation—it becomes all the more apparent why triode stages with their softer turn-off characteristic are enjoying renewed interest.

Because the UL stage makes the transition from Class A to Class B in a similarly gentle manner, it exhibits the same freedom from the nasty sounding notch-distortion problem as the triode stage. See Fig. 3.

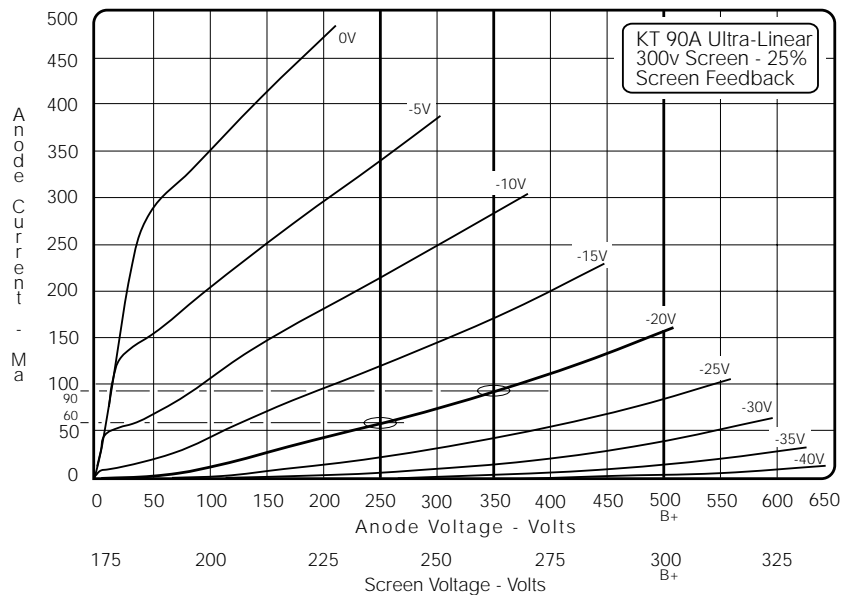
Additionally, the UL stage exhibits a very low input capacitance which is something that must be forsaken with triode operation. Due to the Miller Effect, this value is typically 3-5 times greater with a triode connected output stage than with UL or pentode operation. The stage driving triodes must therefore source current to and sink it from the output stage at a far greater rate than when driving a pentode or UL output stage. This must be done in order to retain equivalent output bandwidth, feedback loop stability and consequent immunity to the reactive loading presented by most loudspeakers.

Thus we see that UL operation can yield the much appreciated sweetness and load tolerance of the triode stage with the power output capacity of the pentode stage all for the price of a well-placed screen-winding within the output transformer.

A properly executed ultra-linear stage offers the advantages of both triode and pentode operation with shortcomings of neither.



**Fig. 2.** Plate current vs. plate voltage for a triode-connected (screen tied to plate) KT90. Note the substantial effect of plate voltage upon plate current; an increase in plate voltage from 250V to 350V results in a 320% increase in plate current—from 70mA to 225mA. Following the highlighted 350V line down from maximum to zero plate-current, note that the amount of negative-grid-drive required to cut off current flow through the tube is -50V and that current flow is gradually turned off with increasing negative control grid bias. Follow the highlighted -50V line over to the 500 plate-volt line, note that plate current has risen from zero to 80mA. Compare this result with Fig. 1b to see that, in the tetrode, -50 control-grid volts will cut off current flow almost completely.



**Fig. 3.** Plate current vs. plate voltage for a KT90, ultra-linearly driven. The screen grid is connected to a dedicated winding of 25% the number of turns on the primary. Note the triode-like plate-current-as-a-function-of-plate-voltage and the gradual cut off of plate current with increasingly negative grid drive. Note also the increase from zero plate current at cut-off to some significant value with increased plate voltage.