

INTRODUCTION

There are many books of circuits, and others giving the theory of various circuits for people with different levels of technical education; but there seems to be a lack of books to help to solve the "obscure" problems that arise when a piece of equipment has been built, but just doesn't work. This book has been prepared to fill that gap, particularly in relation to audio frequency amplifiers.

Perhaps it can be regarded as the gap between *theory* and *practice*. Books of the constructional type give practical instruction, and books of theory undoubtedly cover all the possibilities that can occur to stop our particular piece of equipment from working properly; but how often has it been helpful to have an experienced man at hand to put his finger on the trouble? The author has often successfully played the part of "the experienced man"—even over the telephone. So he realised that what could be achieved this way could well be put into book form. It is with this in mind that the TROUBLE TRACING GUIDE has been prepared. Where the man on the telephone would say to him "so-and-so happens," the reader turns to the guide to find the appropriate symptoms, and there sees a reference to the chapter or chapters explaining the possible causes in detail.

But the book should not be left on the shelf until trouble comes. It has been arranged in a logical sequence for reading, so as to gain valuable permanent knowledge of the subject. When some particular problem arises, and the reader perhaps only remembers that it was dealt with in this book, then he can use the guide. (It has been assumed, of course, that the wiring and circuit values have been checked to diagram, and that still something is wrong.)

Whether the reader has little or much practical experience or theoretical knowledge, the author believes his book will be of interest and help. He has tried to avoid using expressions that those with inadequate technical knowledge would not understand, and he is confident that this presentation will also prove helpful to many who have learned the theory in more technical terms, because often the "classical" explanation does not give a really clear understanding of the matter.

N. H. CROWHURST.

London, 1951.

I

DISTORTION

THIS chapter deals with various kinds of distortion caused by operating valves under incorrect conditions, in some way or other. To understand this matter properly, one must be able to appreciate the full significance of valve characteristics, according to their type. The best means to this end is the drawing of what is known as a load line. Engineering text books make the treatment so mathematical that ordinary un-mathematical people seldom understand it properly, even though they may have passed exams in the subject. So the author makes no apology in offering an explanation in simpler language.

Different Forms of Valve Characteristics

In the first place, there are two ways of showing valve characteristics—this can be confusing. Figure 1 shows both ways for the same

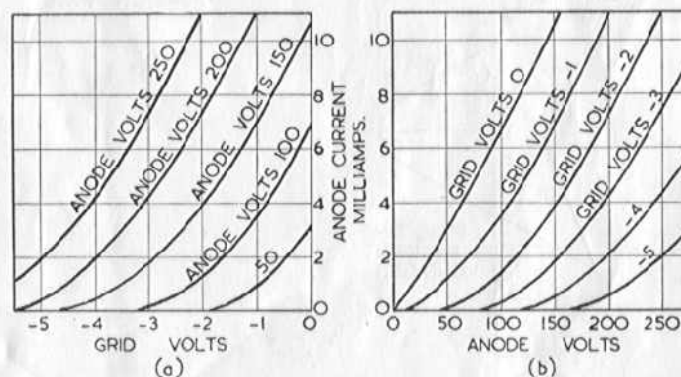

FIG. 1. DIFFERENT PRESENTATIONS OF VALVE CHARACTERISTICS.

type of valve. The arrangement at (a) gives curves showing how anode current changes when grid voltage is altered, for fixed values of anode voltage. If, in use, only anode current fluctuated when a signal voltage fluctuation was applied to the grid, then these curves would tell the whole story. This would happen if anode and cathode (or filament) were connected directly to h.t. plus and minus respectively. But then

AUDIO HANDBOOK No. 1: AMPLIFIERS

there would only be anode *current* fluctuations, and the valve would be no good as an amplifier, because signal *voltage* is also required, whether to be passed on to the grid of the next valve, or to be fed to a loudspeaker through a transformer. As soon as some arrangement is made so that voltage fluctuations are obtained, the curves of Figure 1 (a) cease to tell the story properly.

But for the moment imagine that there are no anode voltage signal fluctuations, so one of these curves could be used. Figure 2 shows the method usually chosen. The grid voltage reference lines are drawn

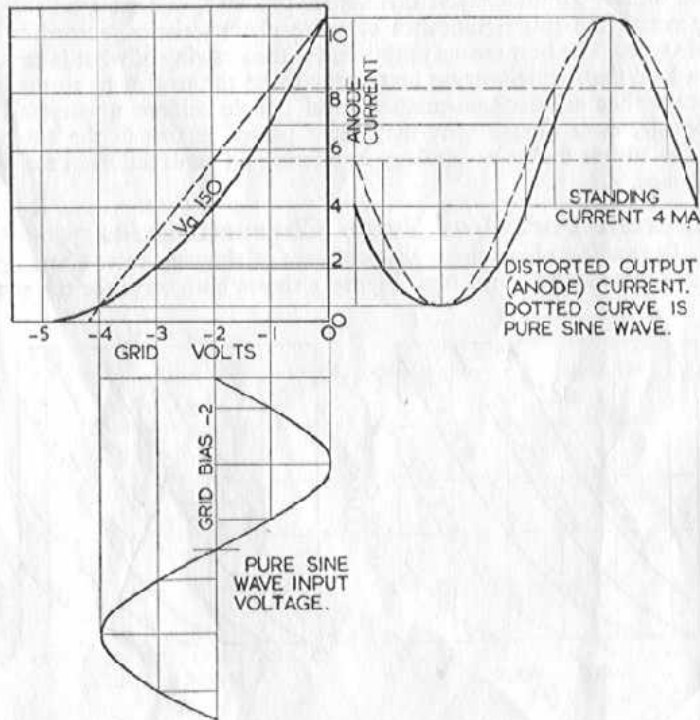

FIG. 2. METHOD OF USING A CURVE FROM FIG. 1 (a).

down further, and a sine wave is drawn on them, representing a pure signal input voltage to the grid. If the characteristic were straight, as shown dotted, then each value of grid voltage would cause the corresponding anode current marked off by the dotted lines horizontally, and extending to the right, so that a sine wave representing a pure signal current fluctuation in the anode circuit could be drawn, as

DISTORTION

shown dotted. However, a practical valve characteristic is curved, so the anode current fluctuations follow the shape at the right drawn in solid line instead of the dotted sine wave. Thus the wave is distorted due to the "curvature" of the valve characteristic.

Now turn to the characteristics shown at Figure 1 (b) for the same valve as that represented at Figure 1 (a). Here graphs have been plotted showing how anode current changes when anode voltage is altered, for six different fixed grid voltages. At (a) the graphs showed how anode current changed when grid voltage is altered, for five different fixed anode voltages. For a triode type valve, these two types of characteristic are similar to look at, and for this reason they can easily be confused at first sight. To know which one is being used, the reference scales must be examined. At (a) the quantity plotted along the bottom is grid voltage, and the curves are "labelled" with anode voltages, while at (b) the quantity plotted along the bottom is anode voltage, and the curves are "labelled" with grid voltages.

Each set of curves presents the same information in a different way. In fact, one set of curves can be made from the other. This is rather laborious, and the reader will probably never bother to do it; but understanding how it can be done helps in seeing their usefulness. Figure 3 shows the method. This is just a copy of the curves at Figure 1, with the labelling left off of the curves themselves, so that numbers

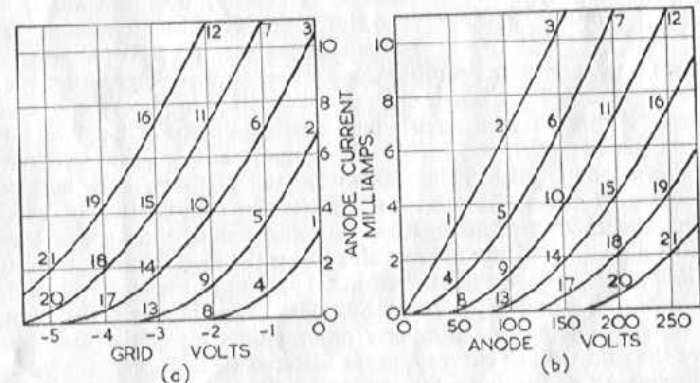

FIG. 3. FIG. 1 REPEATED TO SHOW THE COMPARISON OF THE TWO FORMS OF PRESENTATION.

can be written in identifying the same points on both sets of curves. At (a) a grid voltage is represented by an upright straight line, while at (b) it is represented by a curve. Thus the points 1, 2, 3 are all at a grid voltage of zero on both diagrams, and points 8, 9, 10, 11, 12 are all at a grid voltage of minus 2. At (b) an anode voltage is represented by an upright straight line, while at (a) it is represented by a curve

AUDIO HANDBOOK No. 1: AMPLIFIERS

Thus points 7, 11, 15, 18, 20 are all at an anode voltage of 200 on both diagrams. The reader can trace out the correspondence of other points on both graphs for himself.

Load Lines

But what is a load line? And how does it help show the behaviour of the valve? Suppose the anode h.t. supply, of 250 volts, is connected to the "top" end of a 25,000 Ohm resistor, the "bottom" end of which is connected to any valve anode, as at Figure 4.

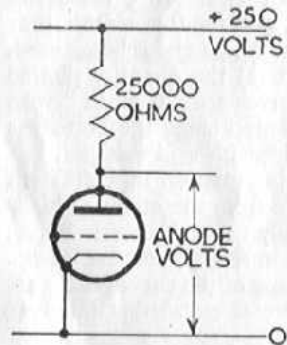

FIG. 4. CIRCUIT FOR SIMPLE LOAD LINE.

If the valve does not pass any anode current, there will be no current through the resistor, and the anode voltage will be the same as h.t. plus, 250 volts positive. But if the valve draws 10 milliamps, there will be a volt drop of 250 volts in the 25,000 Ohm resistor, so its bottom end will be 250 volts negative from h.t. plus, *i.e.*, zero. If the valve draws say, 4 milliamps, there will be a volt drop of 100 volts, leaving the anode at $250 - 100 = 150$ volts positive. A lot more points could be taken, representing different anode voltages according to the current taken by the valve; but they will all be found to connect up in the straight line AB or Figure 5 (a). Whatever happens in

the grid circuit, the anode voltage and current must be given by some point along this line, because of the volt drop in the 25,000 Ohm resistor. For this reason, such a line is called a 25,000 Ohm load line.

At Figure 5 (b), the curves of Figures 1 and 3 (b) are redrawn and the 25,000 Ohm load line drawn on top of them. Now suppose that the grid voltage is minus 1. Then the combination of anode current and anode voltage must be somewhere along the curve marked "grid volts - 1." Since it must also be on the load line AB, the only possible anode voltage and current in the circuit of Figure 4, when the grid voltage is minus 1, is given by point D on Figure 5 (b), about 120 volts, 5 milliamps. Similarly other points along the load line, where the grid voltage curves cross it, lettered C, E, F, G, H, give the anode voltage and current for the grid voltage represented by each curve.

How to Use Load Lines

Figure 6 shows how the information obtained from such curves with a load line can be used to produce an output waveform for a pure input wave, in a manner similar to that used in Figure 2. Anode voltages along the load line AB of Figure 5 (b) are plotted against a scale of grid voltages. The reference lines are again extended downwards

DISTORTION

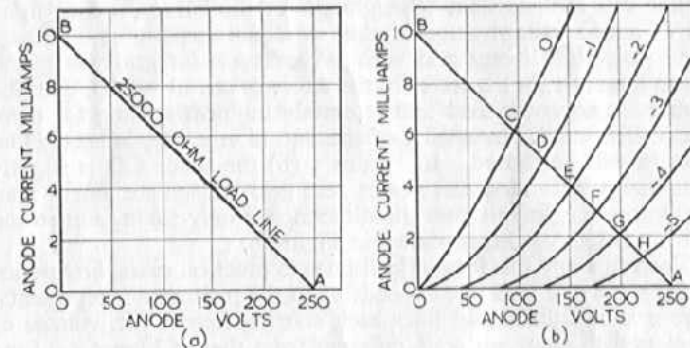

FIG. 5. LOAD LINE IN ITS SIMPLEST FORM—CIRCUIT OF FIG. 4.

and to the right, so that a sine wave can be drawn as input to the grid, and a corresponding output waveform be drawn by reference to the curve. Again, if the curve were straight, the output would be pure, but curvature causes distortion.

In practice this curve need not be drawn to find out whether the

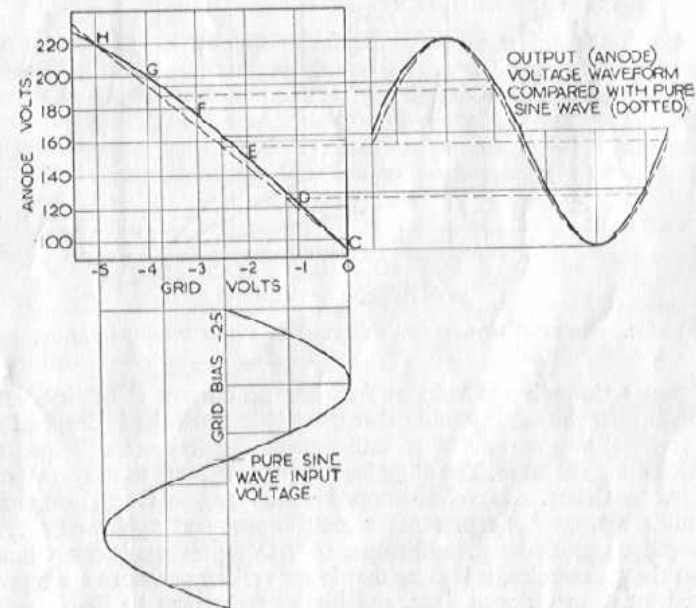

FIG. 6. METHOD OF FIG. 2 USED WITH LOAD LINE OF 5 (b).

load line causes distortion. Straightness of the curve depends upon steps of anode voltage corresponding to equal steps of grid voltage being equal. If adjacent grid voltage curves are for grid voltages at uniform intervals (in Figure 5 (b) the intervals are all 1 volt), then the curves must cross the load line at exactly uniform spacing for there to be no distortion. Inequality of spacing, in any way, indicates that distortion will be caused. In Figure 5 (b) the space CD is slightly longer than GH, and spaces nearer zero grid voltage are longer than those nearer H. In this case the difference is only slight, and so the distortion is only slight, as shown in Figure 6.

Now, to apply this idea of load lines to practical cases, first notice how the slope of a load line depends upon the resistance it represents. Figure 7 shows three load lines each starting from a h.t. voltage of 250, plotted to a current scale different from that of Figure 5. Line

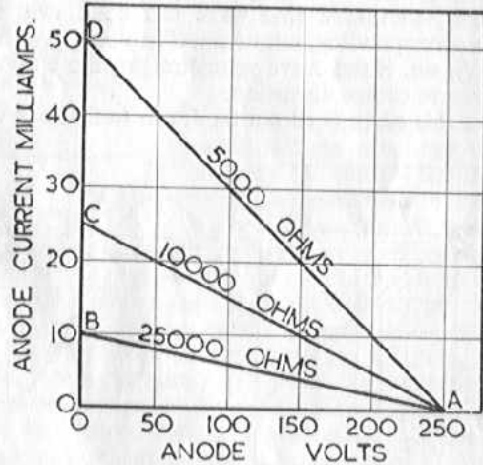

FIG. 7. SHOWING HOW SLOPE OF LOAD LINE DEPENDS ON VALUE.

AB passes through 250 volts at A, when no current is flowing, and through zero voltage (meaning that the whole 250 volts is dropped in the resistor) at a current of 10 milliamps. This represents a load of 25,000 Ohms, as before. The other load lines correspond to 10,000 Ohms and 5,000 Ohms. 250 volts dropped across 10,000 Ohms produces 25 milliamps, so AC represents 10,000 Ohms, and 250 volts across 5,000 Ohms produces 50 milliamps, so AD represents 5,000 Ohms. From these examples, it is clear that lower resistance values are represented by steeper sloped lines, and higher resistances by lines nearer horizontal.

Load Lines for Practical Circuits

Figure 8 shows load lines representing two types of circuit applied to triode type characteristics, and Figure 9 applies the same types of circuit to tetrode or pentode characteristics. At (a) in each case, the load line arrangement represents resistance/capacitance coupling, shown in Figure 10. The load line AB represents the d.c. drop down

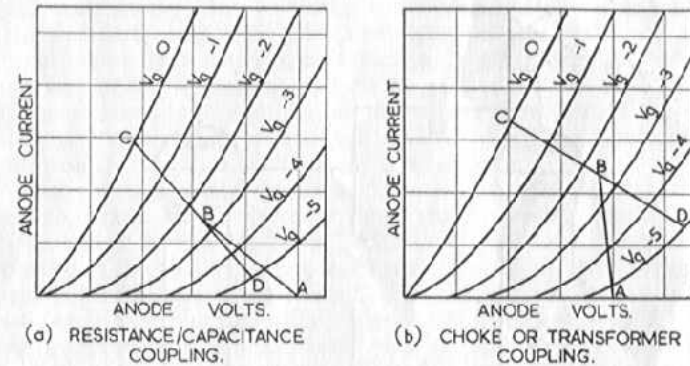

FIG. 8. LOAD LINES FOR PRACTICAL CIRCUITS—TRIODES.

the resistor R_1 , as already explained. But when signal voltages are received at the grid, changing its voltage momentarily from the steady bias value represented by point B (-2.5 volts in Figure 8 (a), -2 volts in Figure 9 (a)), the change of anode voltage will cause charges on the coupling capacitor to be changed, producing small currents in R_2 . This means that from the viewpoint of signal voltages, R_2 is in

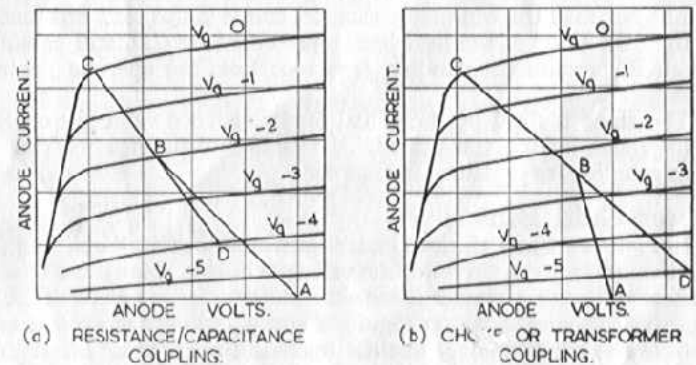

FIG. 9. LOAD LINES FOR PRACTICAL CIRCUITS—PENTODES OR BEAM TETRODES.

parallel with R_1 , reducing the effective load resistance; but the operating point is still fixed by the volt drop down R_1 only. So the operating load line, CD, will have a steeper slope, but will still pass through point B.

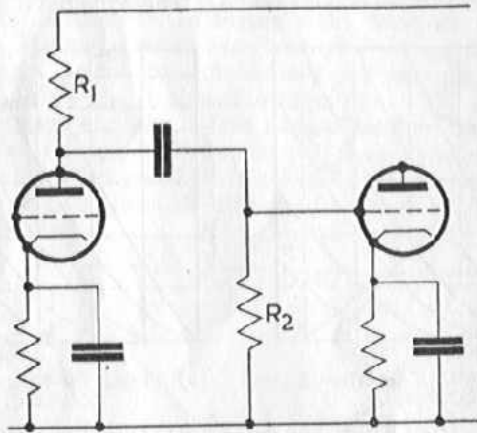

FIG. 10. RESISTANCE/CAPACITANCE COUPLING CIRCUIT.

In (b) of Figures 8 and 9, the load line arrangement is for choke/capacitance or transformer coupling. In each case AB represents the volt drop due to the resistance of the winding connected in the anode circuit. But the winding will have a very high inductance, which is not considered in the load line diagram for the moment. This inductance is used to provide coupling to a load resistance that is much higher than the winding resistance, and it is this load resistance that fixes the slope of the load line, represented by CD, still passing through B, because the winding resistance fixes the operating point due to grid bias.

The slope is fixed by the actual load resistance value for choke coupling, and by the transferred, or matched, resistance for transformer coupling, as explained in Chapter 9.

Wrong Grid Bias

In Figures 8 and 9, the load lines shown are about the "optimum," or best values, for the curves of the valves as drawn. Now turn to see the effect of operating under incorrect conditions. To obtain the full use of the load lines shown in Figures 8 and 9, not only must the load line have the correct slope, but the operating point must be in the correct place along it, otherwise signal voltage applied to the grid will swing the anode current and voltage beyond one end of the useful

part of the load line, before the other is reached (this is what happens if incorrect grid bias is used).

Too little bias means that the end where the zero grid volts curve crosses will be reached first. Unless the valve is used under "power drive" conditions (explained later), when the grid voltage runs past zero, the fact that the grid starts to collect electrons, as well as the anode, means that grid current will cause a volt drop in the grid circuit resistances; this volt drop will start suddenly at one point in the waveform, where the grid passes zero voltage, so the volt drop will not follow the waveform, as it does in the anode resistor, but will come on suddenly, causing distortion. In effect the grid circuit resistance is usually so high that all the voltage above zero is dropped in it, and the waveform at the grid is flattened off as if chopped off at the voltage where the grid passes through zero.

Too much grid bias results in distortion at the other end of the load line, before the positive excursion from bias voltage reaches zero. This is known as "anode bend" distortion, because it is due to the curvature of the anode current characteristic when the grid voltage is almost cutting off the anode current. This form of distortion is not so drastic as grid current distortion. Figure 11 (a) shows a typical waveform produced by insufficient bias, while (b) shows one produced by too much bias, as shown on an oscilloscope screen when the input is pure (shown dotted so that departure from the proper shape can be seen better).

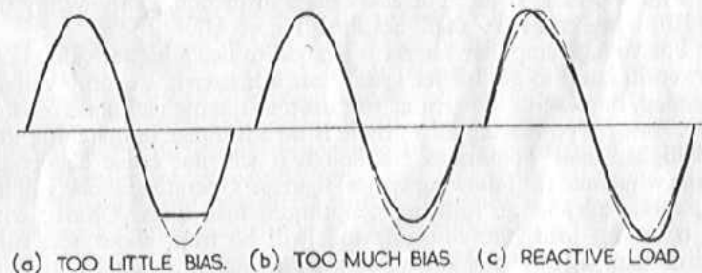

FIG. 11. DISTORTION CAUSED BY VARIOUS INCORRECT OPERATING CONDITIONS. Alternative causes are given in the text.

Wrong Load Resistance

That is what can happen when the correct load is there, but the grid bias is wrong. Now to see what happens when the load goes haywire. The simplest way for this to happen is by using the wrong resistance, or combination of resistances, for the valve in question.

Suppose first that the valve is a triode, with characteristics similar to those in Figure 8, repeated to show this point in Figure 12: with

AUDIO HANDBOOK No. 1 : AMPLIFIERS

the correct load line AB, there is no distortion ; using a higher value, passing through the same operating point, gives a load line such as CD, representing twice the resistance of AB ; this still gives little or

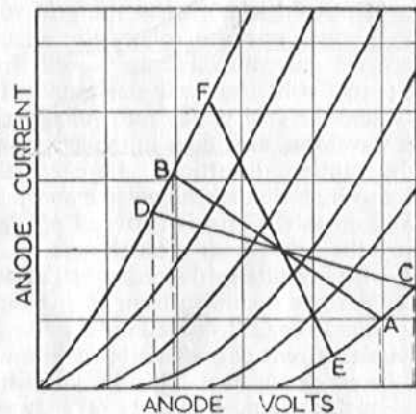

FIG. 12. DIFFERENT LOAD RESISTANCES—TRIODES.

no distortion, and produces a slightly larger anode voltage swing, as shown by the dotted lines. Using a lower value, however, not only drops the available swing, but also causes distortion, as shown by the line EF, representing a value one-third that of AB.

For voltage amplifier stages, it is good to use a higher value than the "optimum" to get higher gain ; but a higher h.t. supply voltage is needed, because of the greater volt drop in the higher anode resistor value. But for power amplifiers there is no advantage in matching to a load higher than "optimum," although it will not cause distortion. To see why, take the following typical figures. Operating anode voltage 250, anode current 40 milliamps, optimum load 4,000 Ohms : with this optimum load, the voltage swing will be from about 120 volts 72.5 milliamps, to about 380 volts 7.5 milliamps, a signal output of about 2.1 watts. Using double the load, 8,000 Ohms, the swing changes from about 95 volts 60 milliamps to about 405 volts 20 milliamps, a signal output of about 1.5 watts.

(The formula for power output is

$$\frac{\text{voltage swing} \times \text{current swing}}{8000}$$

current swing in milliamps, power in watts.)

For triodes, the exact load is not highly important ; but it is better to be on the high side than the low side of the optimum value.

Turning to tetrodes and pentodes with characteristics similar to

DISTORTION

those shown in Figure 9, repeated for this purpose in Figure 13. The optimum load line is AB, and CD and EF represent loads of

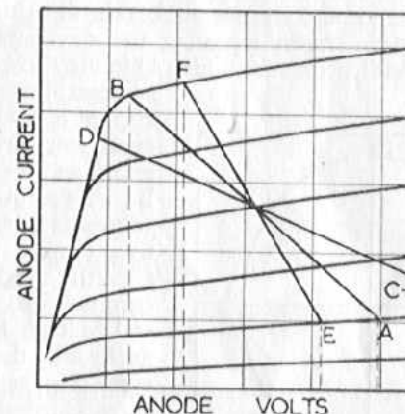

FIG. 13. DIFFERENT LOAD RESISTANCES—PENTODES OR BEAM TETRODES.

double and half optimum respectively. The half value, EF, reduces voltage swing at the output to about half ; but there is little or no distortion. The double value meets the zero grid volt curve where it bends over and begins to meet the others, while the other end of the load line reaches up to very high anode voltages (off the right hand side of the figure). This shows two bad features : (a) excessive distortion is caused ; (b) high anode voltages occur, which may do damage. The result of using too low a value does not cause distortion ; but the output is roughly proportional to load resistance, so valuable gain or power output may be lost.

The waveform caused by working a triode with too low a load resistance is similar to the anode bend distortion of Figure 11 (b), while that caused by working a tetrode or pentode with too high a load resistance causes distortion similar to that shown in Figure 11 (a).

With R/C coupling it must be remembered that the load resistance is not simply the anode coupling resistor, but is effectively the coupling resistor in parallel with grid leak or input resistance of the following stage.

Elliptical Load Lines—Reactive Load

Those cases deal with wrong bias or wrong load, always supposing the load in the valve anode circuit behaves as a pure resistance. In practice, especially at the ends of the frequency range, it is seldom like a pure resistance. Inductances and capacitances in the circuit make the load line "elliptical." This is not so difficult to understand

as is often supposed. The property of a pure reactance, *i.e.*, a capacitor or high Q inductance by itself, is that the peaks of current coincide with zeros of voltage and vice versa.

A load line due to pure reactance takes the form shown in Figure 14. The arrowheads shown represent the direction taken by the operating voltage and current for a high Q inductance. When voltage is a maximum positive, at A, current is zero; quarter of a cycle later current is at maximum, and voltage is zero, at B; another quarter cycle, and voltage is at maximum negative, current is zero, at C; after the third quarter cycle, current is maximum negative, and voltage is zero at D; finally after the fourth quarter cycle the position is back at A. Current reaches any position in its cycle, quarter of a cycle after voltage has passed the same position. For a capacitance, the direction of the arrowheads would be reversed.

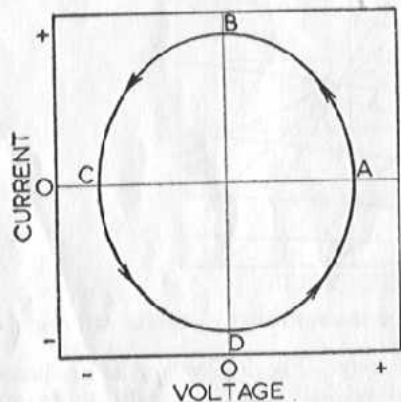

FIG. 14. ELLIPTICAL LOAD LINE DUE TO PURE INDUCTANCE.

In valve circuits pure reactance loads can never occur, because there must be coupling resistances, etc., and the voltage and current never become actually negative, but fluctuate, always in a positive direction. The reactance component appears either in shunt or in series with the known resistance load.

The effect of parallel addition of reactance to a resistance load, AB, across "ideal" valve characteristics (*i.e.*, in which the grid voltage "curves" are all straight, parallel, and equally spaced), working at the operating point C, is shown in Figure 15 (a), while (b) represents the effect of reactance added in series with a resistance load. It is not easy to show elliptical load lines on practical valve characteristics where the effect of reactance causes distortion, because the ellipse goes out of shape, the current waveform being distorted differently from the voltage waveform. But from the ideal ellipses, applied in imagination to actual valve characteristics, it is easily understood that shunt reactance, in the case of triodes and series reactance, in the case of tetrodes or pentodes, cause distortion.

Practical Cases of Elliptical Load Line

In tetrodes or pentodes, series reactance causes distortion very like that caused by too high value of resistance load. One kind of series

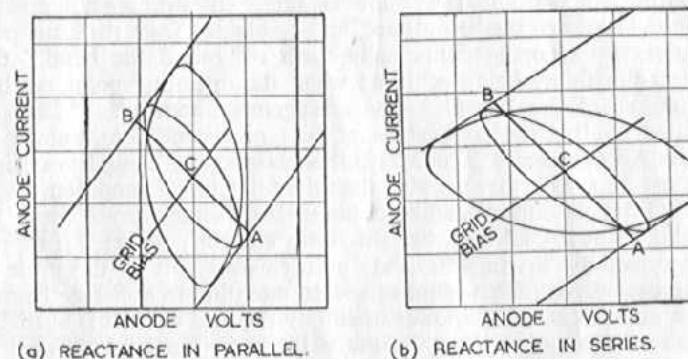

FIG. 15. "IDEAL" LOAD LINES FOR REACTANCE ADDED TO FIXED RESISTANCE, AB.

reactance normally met in these circuits is the coupling capacitor, so this distortion can arise at low frequencies if the coupling capacitor following a tetrode or pentode stage is too small. A commoner cause is the speech coil reactance of a loudspeaker, used as a load for a tetrode or pentode output. This is partly why tetrodes or pentodes need correction capacitors connected, either from anode to earth, or across the secondary of the output transformer.

In triodes, the kind of shunt reactances that may cause trouble are the grid input capacitance of the following stage, which is unlikely, and the inductance of a coupling choke or coupling transformer primary. The latter will cause distortion particularly at low frequencies, if the inductance is not high enough for the purpose. Notice that this distortion is quite different from that produced by saturation of the core of the choke or transformer, due to too high a level at too low a frequency. The latter is quite another source of distortion, and one usually less often met in modern practice.

The kind of waveform produced is rather different from anode bend distortion, although it does not sound very different. Figure 11 (c) shows the waveform produced by a coupling choke of too low an inductance value.

Push-Pull Working Gives Bigger Outputs

Push-pull operation, particularly of triode type valves, enables a greater output to be obtained from each valve with less overall distortion. It was noted that use of too low a load value with triodes causes distortion similar to the anode bend type. Using two valves in push-pull allows both of them to work with a lower load resistance, giving a bigger power output, because the bend distortion cancels in

the output. This is known as "low-loading." By working at a greater negative bias, even bigger outputs can be obtained from the same pair of valves by swinging deliberately further "round the bend," the greatest possibility being achieved when the operating point reaches the middle of the "bend"—the arrangement known as "Class B operated." Intermediate values of bias give conditions known as "Class AB operated." These have the advantage of being less critical to adjust for satisfactory working than the full Class B condition.

Still bigger outputs can be obtained from some types of valve by working them in push-pull like this, with a slightly higher h.t. supply voltage, and by driving the grids positive over part of the cycle at maximum output. This requires special attention to the stage before, to see that the necessary power to supply the grid current is available without causing distortion. As much literature has been devoted to circuit designs for this purpose, this book will not go into details of such circuits.

Recognising and Locating Cause of Distortion

From the information in this chapter it is evident that a variety of causes can introduce distortion of one of the types shown in Figure 11, and careful checking up is necessary even after the offending stage has been located, in finding just why the distortion appears. If an oscilloscope is available, the distortion is easy to recognise from this figure; but in the absence of an oscilloscope, it may be necessary to rely on listening tests. Waveforms as in Figure 11 (a) result in sound very like that produced if the speech coil is knocking against the pole piece or some other object at one end of its travel. Having checked that this is not happening, it will be known that one of the types of distortion resulting in this kind of waveform must be occurring. Waveforms shown at (b) or (c) do not cause such noticeable distortion to the ear, but can be recognised best on certain programmes as producing a rather sharp reproduction.

If all sounds above a certain level, regardless of frequency (pitch), are distorted, then the trouble is incorrect loading or biasing of a valve somewhere. If the low frequency or high frequency sounds are particularly distorted, then the trouble arises due to reactances, the low due to a coupling inductance (choke or transformer primary) of too low value, the high due to insufficient correction capacitance on the output tetrode or pentode.

A simple check for localising the cause of distortion is to measure anode currents, or volts across bias resistors, while the amplifier is in use. Anode bend causes a rise in current or bias volts when signal is present. Grid current causes a drop in current or bias volts. Slight changes proportional to signal level are normal; but a sudden change when a certain level is reached indicates distortion. Bias or load resistors should be altered accordingly to correct the defect.

INSTABILITY

SOME of the results of instability are not unlike those produced by the forms of distortion dealt with in the last chapter, which is why this one is put next to it. A variety of effects come under the heading of instability. The word means unwanted oscillation, or a tendency to oscillate. The frequency of unwanted oscillation is usually either low or high, often below or above the audio range of frequencies. Below the low end it causes what is known as "motor-boating." Above the high end, it causes "h.f. blocking." Sometimes it is not above the range of audible frequencies, when a high pitched squeal will be heard.

Motor-boating

Take motor-boating first, because the possible causes are fewer than for h.f. forms of instability. It will not occur in amplifiers having fewer than three stages. It is due to positive feedback at a low frequency. The most common cause is insufficient decoupling of the h.t. supply. Use of either larger decoupling capacitors, or smaller coupling capa-

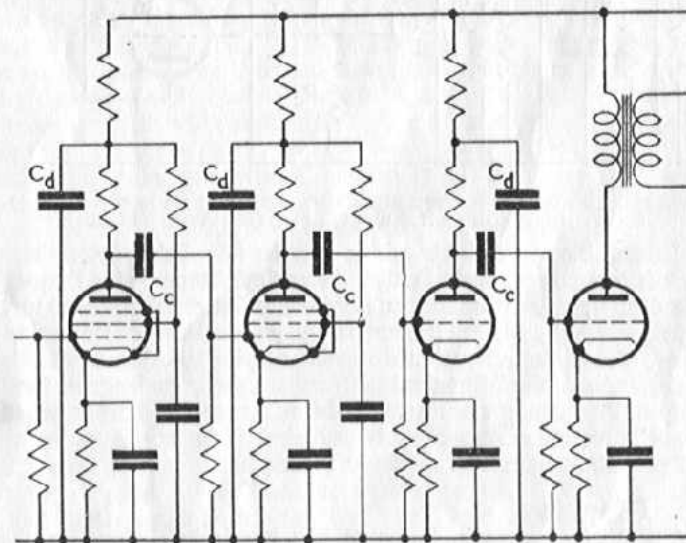

FIG. 16. TYPICAL CIRCUIT LIABLE TO MOTOR-BOATING.