

the output. This is known as "low-loading." By working at a greater negative bias, even bigger outputs can be obtained from the same pair of valves by swinging deliberately further "round the bend," the greatest possibility being achieved when the operating point reaches the middle of the "bend"—the arrangement known as "Class B operated." Intermediate values of bias give conditions known as "Class AB operated." These have the advantage of being less critical to adjust for satisfactory working than the full Class B condition.

Still bigger outputs can be obtained from some types of valve by working them in push-pull like this, with a slightly higher h.t. supply voltage, and by driving the grids positive over part of the cycle at maximum output. This requires special attention to the stage before, to see that the necessary power to supply the grid current is available without causing distortion. As much literature has been devoted to circuit designs for this purpose, this book will not go into details of such circuits.

Recognising and Locating Cause of Distortion

From the information in this chapter it is evident that a variety of causes can introduce distortion of one of the types shown in Figure 11, and careful checking up is necessary even after the offending stage has been located, in finding just why the distortion appears. If an oscilloscope is available, the distortion is easy to recognise from this figure; but in the absence of an oscilloscope, it may be necessary to rely on listening tests. Waveforms as in Figure 11 (a) result in sound very like that produced if the speech coil is knocking against the pole piece or some other object at one end of its travel. Having checked that this is not happening, it will be known that one of the types of distortion resulting in this kind of waveform must be occurring. Waveforms shown at (b) or (c) do not cause such noticeable distortion to the ear, but can be recognised best on certain programmes as producing a rather sharp reproduction.

If all sounds above a certain level, regardless of frequency (pitch), are distorted, then the trouble is incorrect loading or biasing of a valve somewhere. If the low frequency or high frequency sounds are particularly distorted, then the trouble arises due to reactances, the low due to a coupling inductance (choke or transformer primary) of too low value, the high due to insufficient correction capacitance on the output tetrode or pentode.

A simple check for localising the cause of distortion is to measure anode currents, or volts across bias resistors, while the amplifier is in use. Anode bend causes a rise in current or bias volts when signal is present. Grid current causes a drop in current or bias volts. Slight changes proportional to signal level are normal; but a sudden change when a certain level is reached indicates distortion. Bias or load resistors should be altered accordingly to correct the defect.

INSTABILITY

SOME of the results of instability are not unlike those produced by the forms of distortion dealt with in the last chapter, which is why this one is put next to it. A variety of effects come under the heading of instability. The word means unwanted oscillation, or a tendency to oscillate. The frequency of unwanted oscillation is usually either low or high, often below or above the audio range of frequencies. Below the low end it causes what is known as "motor-boating." Above the high end, it causes "h.f. blocking." Sometimes it is not above the range of audible frequencies, when a high pitched squeal will be heard.

Motor-boating

Take motor-boating first, because the possible causes are fewer than for h.f. forms of instability. It will not occur in amplifiers having fewer than three stages. It is due to positive feedback at a low frequency. The most common cause is insufficient decoupling of the h.t. supply. Use of either larger decoupling capacitors, or smaller coupling capa-

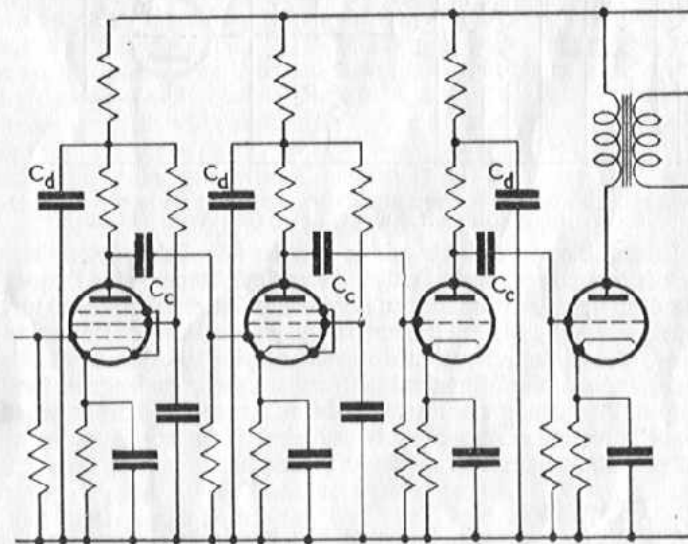

FIG. 16. TYPICAL CIRCUIT LIABLE TO MOTOR-BOATING.

AUDIO HANDBOOK No. 1: AMPLIFIERS

citers, may effect a cure. Figure 16 shows one circuit where this may be the case, and the capacitors marked C_c may be made smaller, or those marked C_d larger.

Another circuit that can be unstable is shown in Figure 17. The cause is usually unbalance between the output valves at extremely low frequencies, due to slightly different values of the lettered components that should be identical. Although this circuit has been in favour with quality enthusiasts, a good phase-splitting transformer saves a valve, avoids this cause of instability, and generally gives quality not inferior to that from the circuit of Figure 17.

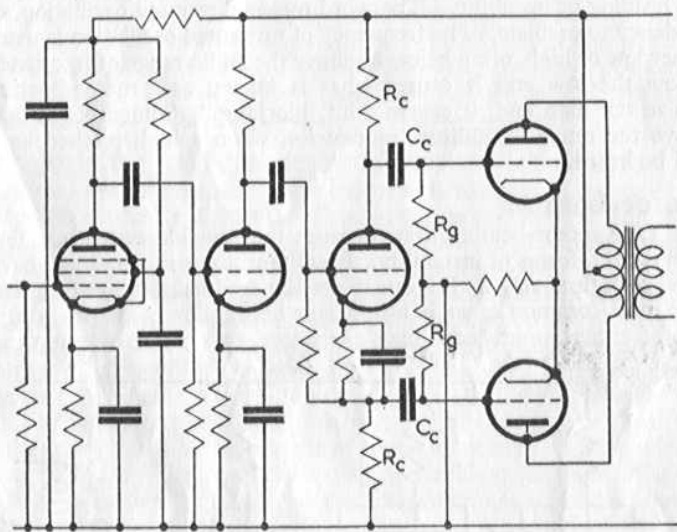

FIG. 17. AN AMPLIFIER WITH PUSH-PULL OUTPUT FED FROM A PHASE-SPLITTING STAGE CAN SUFFER MOTOR-BOATING TROUBLE.

In amplifiers with high gain it may be found that increasing the value of decoupling capacitor only reduces the motor-boating frequency, while changing the coupling capacitors has little effect, or may raise the frequency slightly. The amount of gain makes it impractical to increase decoupling enough to prevent the instability. Under these circumstances, a useful method is to reduce the impedance of the h.t. supply unit. A good circuit that reduces h.t. supply unit impedance, and at the same time supplies a high degree of smoothing, as required for high gain amplifiers, is shown in Figure 18.

H.F. Blocking

There are two main forms of h.f. instability: those involving several stages, and those where just one valve oscillates by itself. Where

INSTABILITY

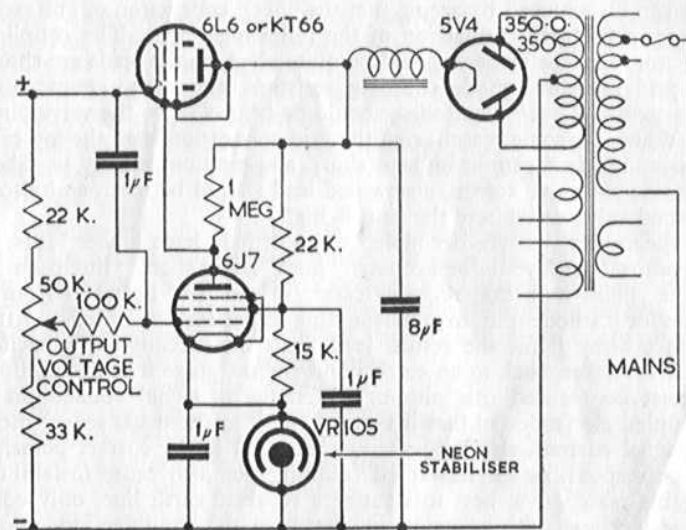

FIG. 18. REDUCTION OF H.T. SUPPLY UNIT IMPEDANCE. USING THIS CIRCUIT HELPS WITH MOTOR-BOATING AND OTHER PROBLEMS OF INSTABILITY.

the oscillation is continuous, the effect of both is somewhat similar. The amplifier is working at full output, or nearly so, at a frequency so high that it is inaudible. In the absence of signal, the output appears unusually quiet. The h.f. oscillation may be strong enough to prevent any desired sounds coming through at all, or it may be that just the strongest sounds will temporarily reduce the strength of h.f. oscillation, allowing a little sound to break through. Sometimes, where the h.f. oscillation is not very strong, practically all the sound gets through; but it sounds as if it is breaking through—quite a similar effect to that produced by an intermittent connection just touching.

The kind of oscillation that occurs through several stages, usually the whole amplifier, is due to feedback from output to input at a very high frequency, beyond the audio range. Amplifiers with very high gain are particularly susceptible to this trouble. If the frequency should be within the audio range the trouble is more obvious. To prevent stray coupling, which might cause such oscillations, each stage should be separated from the next by an earthed metal screen, and the wiring should be arranged so that connections belonging to each stage are kept separate. The layout should keep stages near the output well away from those near the input end of the amplifier. It is good to arrange the wiring so that "hot" leads are as short as possible.

This can be achieved by seeing that the anode connection of one stage is near to the grid connection of the following stage. The coupling capacitor, or transformer, should be quite close, so the leads are short, and grid resistors, anode coupling resistors, and other components connected to "hot" electrodes, should be kept close to the valve pins.

Where for some reason, *e.g.*, the grid connection is on the top cap, the coupling lead cannot be kept short, and may not readily be taken up inside the valve screen, a screened lead should be used, and also a screened valve cap where the gain is high.

Electrodes that are decoupled to earth may have longer leads, if that assists the layout for keeping "hot" leads short. But there is another point here that requires care: a lead may be taken from a screen or cathode pin to a decoupling capacitor, mounted a little distance away; but the return lead from this decoupling capacitor should be taken back to an earth point for the stage it is decoupling. It must be realised that although there is no signal voltage on a decoupled electrode (so that it is not "hot" in the usual sense) there is a signal current, and if this is not returned to the correct point, it can be responsible for unwanted coupling that will cause instability. For this reason it is best to arrange a separate earth line, only connected to chassis at one point, preferably at the amplifier input, and connect all earth returns from each stage back to one point on the earth

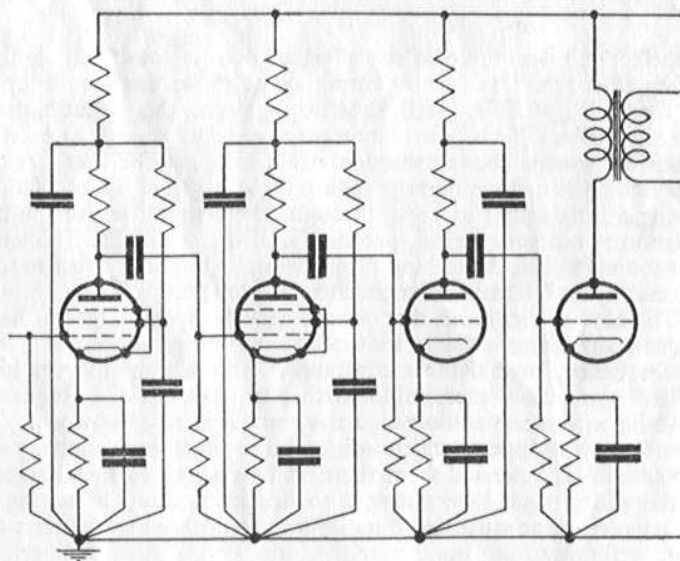

FIG. 19. METHOD OF EARTH WIRING TO AVOID INSTABILITY AND OTHER TROUBLES.

"line." Figure 19 shows the method diagrammatically. If metal-cased electrolytic capacitors are used, it may be advisable to use a chassis earth, where the chassis mounting forms the earth return; but care should be taken to see that the capacitors are near to the stage to which they are connected. It is simpler, for high gain amplifiers, to use one of the carton-packed electrolytics, so that mounting position is not so important, and the necessary care can be taken by means of the negative return lead.

Turning to h.f. oscillation in single valves by themselves, one possibility occurs with beam tetrodes, such as the KTZ63, as high gain amplifiers. Some of the recommended circuits for these valves use a high series screen feed resistor with a decoupling capacitor to earth, as in Figure 20. But under some conditions this circuit will produce an oscillation of extremely high frequency, due to the geometrical structure of the beam electrodes. When this happens, the anode current falls almost to zero, and the screen volts drop down nearly to zero. The frequency of oscillation is so high that it is not passed on to later stages, but it blocks signal in the valve concerned, giving the break-through effect. The cure is usually effected by using a lower value of screen feed resistor, with perhaps a somewhat lower value of anode resistor, to maintain the correct balance of anode and screen currents.

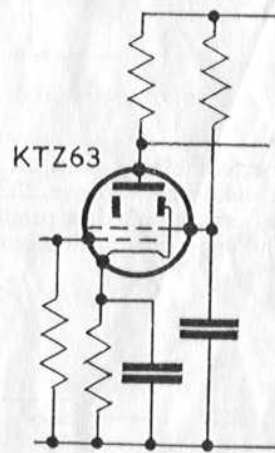

FIG. 20. THIS BEAM TETRODE CIRCUIT CAN CAUSE H.F. BLOCKING.

The next possibility occurs generally in high slope output valves. Both triodes and pentode or tetrode types are subject to it. The cause is that the grid wiring forms a h.f. tuned circuit, and the anode load is inductive at the frequency of oscillation. A capacitor from anode or cathode will sometimes cure this; but the more general cure is the insertion of resistors known as "anode stoppers" and "grid stoppers." For pentodes or tetrodes, sometimes screen stoppers are necessary as well. Suitable values are: 50 to 500 Ohms for anode stoppers, according to valve impedance; and 5,000 to 15,000 Ohms for grid stoppers, again according to size of valve (larger valves requiring lower values because of the grid input capacitance). Figure 21 shows a typical push-pull output stage with grid and anode stoppers fitted.

It is important that "stopper" resistors should be connected so the resistor itself is right against the valve-holder pin.

AUDIO HANDBOOK No. 1 : AMPLIFIERS

A problem occurs where this form of oscillation starts up in an output intended for power drive operation. Grid stoppers cannot be

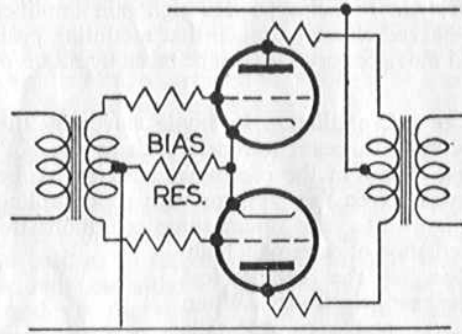

FIG. 21. METHOD OF WIRING GRID AND ANODE STOPPERS.

inserted as in Figure 21, because they would defeat the object of providing power drive. The only alternative is to provide a stopper resistor connected in parallel with the drive output, as in Figure 22. The appropriate value can only be determined by experiment, as it

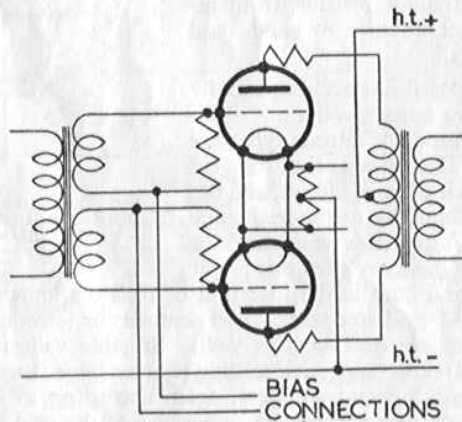

FIG. 22. STOPPER CONNECTIONS WITH POWER DRIVE (CLASS B₁).

depends on the design of the transformer as well as on the types of valve used for both drive and output.

INSTABILITY

Locating H.F. Oscillation

Oscillation originating in a single stage can usually be located by voltage and current measurements. A valve, known to be up to standard, is found to be working at low anode current, with apparently almost zero bias and full h.t. volts on the anode. All circuit values check, so it seems as if Ohm's Law has gone wrong! H.f. oscillation is the explanation—only part of the actual bias being produced across the self-bias resistor, the rest caused by grid current. If the oscillation causes blocking, the voltages will show a change whenever sound breaks through.

Parasitic Oscillation

There is another type of oscillation that appears, sometimes in Class B amplifiers using power drive, only when a signal is being passed. The waveform on an oscilloscope is shown in Figure 23. A shock-excited wave train is set up at each point where grid current ceases. Usually the frequency of this wave train is too high to be audible, and if only the one note, shown in Figure 23, were being passed through the amplifier, there would be no audible evidence of the effect. The trouble becomes evident when mixed signals, such as music, are passed through the amplifier. The h.f. oscillation during part of the wave has the effect of choking higher frequencies in the signal for part of the low frequency wave only, so the reproduction is like a rather bad case of intermodulation. When a low frequency is reproduced at high level, so as to cause this effect, the higher frequencies sound "dithery."

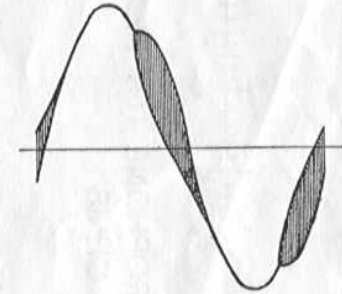

FIG. 23. PARASITIC OSCILLATION.

To cure this trouble, lower value shunt grid stopper resistors (Figure 22) should be tried. If reducing this value fails to stop parasitic oscillation before it causes distortion in the drive stage a better drive transformer is needed, probably with less step-up, or greater step-down.

