

Emulation of Amplifier Overdrive Through the Use of the Nonlinear Output Response of Diodes

Dustin Lindley, Nishant Parulekar

*Department of Physics, University of Illinois at Urbana-Champaign
1110 West Green Street, Urbana, IL 61801-3080, USA*

Harmonic distortion is the most commonly used electric guitar effect. We have constructed a distortion pedal to emulate the sounds of overdriven tube amplifiers. The fuzz box created was designed for high versatility in controlling many parameters of an audio signal while at the same time retaining a simplicity that would allow it to be reproduced as a laboratory experiment. The output of the fuzz box is analyzed in terms of harmonic content and sound.

I. INTRODUCTION

Harmonic distortion of signals is a desired sound for many musicians. However, there are many parameters that can be altered in order to subtly or drastically change the wave form and hence sound. We have tried to design a laboratory experiment for the Physics of Musical Instruments class that would allow students to understand the physics, theory, and application of distortion. Additionally, the lab is designed so that students can investigate the physics behind various stages of the signal processor in order to create their own desired fuzz box.

After studying how various diode clamps produce current in response to an applied voltage, the selected diodes were used in the box as primary sources of differing distortion. To quantify output signals, Fourier analysis was performed to examine the harmonic content of a signal. Though the fuzz box is intended for use with an electric guitar signal, we used a simplified signal of frequency f , produced by a wave generator to produce plots of the frequency response of the fuzz box.

After the circuitry was perfected for use, a design was laid out to house the electronics. Instructions were then created for the production of both the circuitry and the box. The entire process and results will be made available as a laboratory experiment as well as a step-by-step instructional/educational process on the Internet.

II. BACKGROUND

Older Methods of Distortion

Before the popularization of fuzz boxes, the frequently undesired sound of distortion was produced by driving an amplifier at levels not

within the device's manageability. The primary method of achieving this status was to increase the levels of the signal to an amount that exceeded the amplifiers processing capabilities. This resulted in a clipping of the signal such that the top and bottom portions of the wave were cut off, which limits as a square wave. This is one of the simplest ways to describe distortion.

The Demand for Distortion

The sounds of overdriven amplifiers became popular for many musicians. As such, the demand for controlling the type of distortion also surfaced. There were several problems with strictly using the amplifier for distortion. One major problem was that a large volume was necessary to get to the critical stage of overdriving an amplifier. This was not practical for performers who wanted a specific sound at lower levels. A consequence of intensely driving an amplifier was that the electronics were often subject to erosion of effectiveness. Another major drawback was that each amplifier tended to have its own characteristic distortion sound, so that the option of having a variety of distortions was not offered. As such, these limitations created a need for a portable preamp that allowed musicians a cheap, small, and practical control over their sound.

III. THE PHYSICS OF THE DIODE

Physical Structure

One of the simplest types of semiconductor devices is the diode. A diode is made up of an N junction (cathode) and a P junction (anode). Chemical composition ranges from germanium to silicon to gallium arsenide. All materials work essentially the same way.

Unlike some other semiconductors, a diode cannot produce gain in signal (a higher output than input). However, its nonlinear response to voltage is useful. The diode functions as a one-way valve for current.

Current-Voltage Relationship

When a voltage difference is applied across an N-type crystal forming an electric field, the free electrons travel in the direction of the field and carry current.

The P-N junction, where the two types of semiconductor materials join, contains atoms are then fixed in the crystal so that a potential barrier on each side of the junction is formed within a depletion zone. This is the region where all free electrons and holes recombine and all carriers are depleted from the zone. Essentially, the depletion zone acts as an insulating barrier between the cathode and anode regions. As the voltage is increased, the depletion zone becomes thinner and thinner, and the current through the depletion zone grows exponentially as more and more electrons are able to tunnel across the barrier. The most commonly used model of a diode claims that the diode is a switch, and at a certain threshold voltage the switch is turned on, and current flows. This works well for most applications, but the idea here is to take advantage of that exponential relation by driving the diode around its threshold voltage. The most common threshold voltages are from 0.5 V to 1.5 V.

IV. THEORY OF HARMONIC DISTORTION

In a “clean” signal, a linear relationship is desired between the output response, R_o and the input stimulus,

$$S_i : R_o(S_i) = K S_i \quad (1)$$

where K is the constant of proportionality. To simplify the examination of a guitar signal, we assume it to be a pure tone signal produced by a wave generator with a single frequency, f . We define angular frequency as $\omega = 2\pi f$

The input stimulus is a time-dependent function,

$$S_i(t) = A_i \cos(\omega t) \quad (2)$$

where A_i is the amplitude of the input stimulus. Thus the output response also becomes time dependent:

$$R_o(t) = A_o \cos(\omega t) \quad (3)$$

where $A_o = K A_i$ is the amplitude of the output response.

To grasp the basic idea of harmonic distortion, we use a very simple example. Let us first consider the mild nonlinearity of a quadratic response:

$$R_o(S_i) = K (S_i + \epsilon S_i^2) = K S_i (1 + \epsilon S_i) \quad (4)$$

$$(\epsilon S_i \ll 1)$$

Here, the non-linearity parameter, ϵ (with units of $1/S_i$), is assumed to be small. So here, we have in addition to the $K S_i$ linear response term, a small, non-linear quadratic response term, $\epsilon K S_i^2$, which is the lowest-order deviation possible from a purely linear response, (1).

Because the output response is dependent on time,

$$R_o(t) = K A_i \cos(\omega t) + \epsilon K A_i^2 \cos^2(\omega t) \quad (5)$$

We can use the trigonometric identity

$$\cos^2 \theta = \frac{1}{2} (1 + \cos(2\theta)) \quad (6)$$

to get the new output response with harmonic content information:

$$R_o(t) = K A_i \cos(\omega t) + \frac{1}{2} \epsilon K A_i^2 + \frac{1}{2} \epsilon K A_i^2 \cos(2\omega t) \quad (7)$$

We now see that this quadratic non-linear response to a pure input tone of f frequency produces not only the fundamental frequency (or first harmonic) f , but also a small second harmonic component with double the fundamental frequency and with amplitude $\frac{1}{2} \epsilon K A_i^2$. This is due to the $\cos(2\omega t)$ term, that is, $2f$. An additional product of this nonlinearity is a DC shift or offset, that is, a shift in the average value of the signal, as a result of the $\frac{1}{2} \epsilon K A_i^2$ term.

Because this output waveform is more sharply peaked at top and flatter at the bottom than its input waveform, we consider it distorted.

Increasing Nonlinear Response

With increased nonlinearity, such as quartic ($\epsilon K S_i^4$), quintic ($\epsilon K S_i^5$), and so on, higher order harmonics are produced (4th, 5th, 6th) respectively in addition to the fundamental frequency.

The basic diode circuit we use is a symmetric clamp:

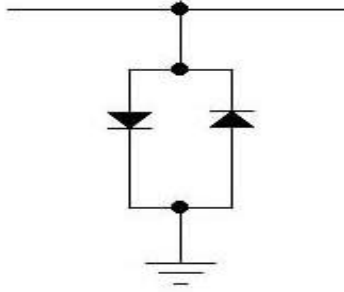

Fig. 1 – Symmetric Diode Clamp

In this case, there is an exponentially growing non-linear response, $R_o(S_i)$ which is modeled as:

$$R_o(S_i) = K [\exp(\alpha |S_i|) - 1] \quad \text{for } S_i \geq 0, \alpha > 0 \quad (8)$$

$$R_o(S_i) = K [1 - \exp(\alpha |S_i|)] \quad \text{for } S_i < 0, \alpha > 0 \quad (9)$$

where K is a positive constant as before and the nonlinear parameter α is also constant.

Through Taylor series expansion, we find that very small values of input stimulus, $|S_i|$ result in a fairly linear output response. However, as the S_i value increases, each of the successive higher order terms (quadratic, cubic, quartic, etc.) play an increasingly important role in how the wave takes shape. The output response then becomes:

$$\begin{aligned} R_o(t) &= R_o(S_i(t)) \\ &= \alpha K A_i \cos(\omega t) * [1 - (\alpha A_i |\cos(\omega t)|)^2 / 2! \\ &\quad + (\alpha A_i |\cos(\omega t)|)^2 / 3! - (\alpha A_i |\cos(\omega t)|)^3 / 4! \\ &\quad + (\alpha A_i |\cos(\omega t)|)^4 / 5! + \dots] \end{aligned} \quad (10)$$

Here, the higher-order Taylor series terms correspond to the higher-order harmonics of the fundamental frequency: 2f, 3f, 4f, 5f,

The result is a general clipping of the waveform. The degree of clipping/distortion on the signal depends on the specific exponential non-linearity of each diode loop's current-voltage relationship, as well as the amplitude of the input signal. Several diode loop I-V plots are shown below.

In general, the higher the exponential response to the voltage, or the higher the amplitude of the input, the more distorted the wave signal sounds-- because there are more odd harmonics produced. The waveform itself approaches that of a square wave with equation:

$$\begin{aligned} f(q) &= \frac{4}{p} \sum_{m=1}^{\infty} \frac{\sin[(2m-1)q]}{(2m-1)} = \\ &\frac{4}{p} \{ \sin q + \frac{1}{3} \sin 3q + \frac{1}{5} \sin 5q + \dots \} \end{aligned} \quad (11)$$

This limiting case consists of only odd harmonics. In most cases we find a mix of both odd and even harmonics in varying degrees.

V. FUZZ BOX CIRCUITRY

The circuitry used to produce harmonic distortion is fairly straightforward in design. Operational amplifiers (op amps) are the active elements in the circuit, and we opted to use Texas Instruments TL-072 chips, which have two op-amps per 8-pin package. These chips have input impedance on the order of $10^{12} \Omega$, with field-effect transistors on the inputs. It is easiest to analyze the circuit in terms of stages, then look at the whole. The main stages are the input amplifier, the diode clipping stage, the boost stage, and the tone and attenuation stage. It is important to note that this circuit is capable of producing output levels that would damage amplifiers, and is intended to be used intelligently.

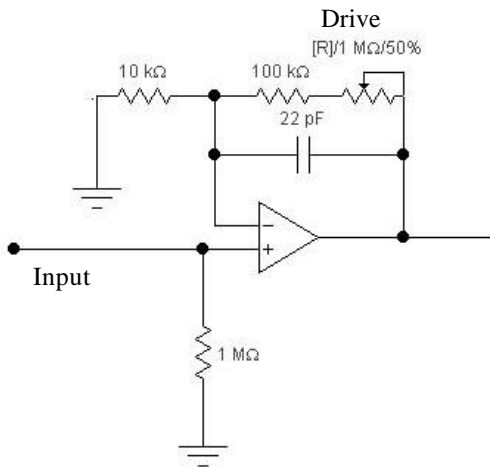

Fig. 2 - Input Amplifier Stage

This stage takes the output from a guitar and amplifies it using an op amp in the non-inverting configuration. The gain for this stage ranges from 11-110 by varying the Drive potentiometer (pot), so if our guitar input signal amplitude is 100 mV, we can expect the amplitude after this stage to be from 1 V to 9 V. The 22 pF capacitor in the feedback loop serves to roll off the output at frequencies above 20 kHz. This reduces noise in the circuit. The resistor (1 M Ω) on the V+ input of the op amp insures that the input is not forced to take current, which can immediately ruin the chip.

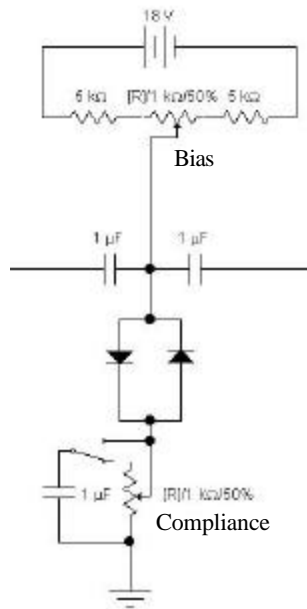

Fig. 3 - Diode Clipping Stage

In this stage, the diode clipping occurs, obviously. We've opted to use various diodes in the clipping section by attaching them to a rotary switch for each orientation in the diode loop. The other components in this stage modify how the clipping occurs. Above the diode loop, we have a variable voltage divider that provides a DC offset to the AC signal coming in on the left. The capacitors on the left and right of the junction where the diode loop is connected keep this DC offset isolated to this section of the fuzz box. The voltage divider provides around ± 0.5 V of "bias." This bias leads to asymmetric clipping, because of the DC offset. If we have a positive bias, then the upper part of the waveform will be more clipped than the lower. The potentiometer in the bottom of this stage limits the amount of current that the diodes can pass. Also, the 1 μ F capacitor (which can be turned off via a switch) provides a route to ground for higher frequencies, which has the effect of emphasizing the lower frequencies.

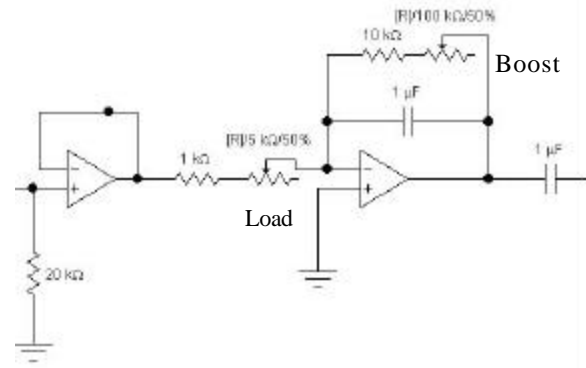

Fig. 4 - Boost Stage

This stage is another gain stage, similar to the input amplifier in this respect, although arranged differently. The first op amp is a buffer. The second is an amplifier in the inverting configuration that has a gain from 2 to 100. The first pot (5 k Ω) is the load pot, and the second (100 k Ω) is the boost pot. The boost section can be overdriven to give distortion when the gain of this section is large enough that the op amp goes to ± 9 V, again leading to clipping and harmonic distortion. Also, when the load pot is all the way up (0 Ω), there should be current limiting from the previous op amp, producing distortion in another way. The capacitor on the right stops any DC offset.

VI. DESIGNING THE BOX

Practicality

The design for the fuzz box, which was finally named “Dr. Strangefuzz,” had to balance two essential necessities: practicality and aesthetics. Practicality was the harder issue to address. Examining the schematics of the fuzz box, one notices that there are seven pots, two on/off type switches, two 12-position diode selectors, a stomp switch, and an on-off button. That allows for a lot of control, but necessitates very careful placement of components. Once it was decided that these were all necessary, the box was laid out so that the knobs went in order of what a musician would logically want to sequentially control. Enough space was provided to adequately vary each parameter without accidentally altering any neighboring settings. The box-drilling layout is in the back of this report.

Inside, the circuitry layout provided enough room for a first-time student to have room for small error in measurement as well as space to fine-tune dimensions for their own wishes.

One problem still in contention is the addition of an additional compliance capacitor selector. This would drastically increase the problem of wire-traffic density. This is mainly due to the fact that the planned area of possible mounting occurs directly above the circuit board—in the mouth of madness, as far as wiring goes. In place of a selector switch, we’ve used pins so that changing the capacitor is no more difficult than replacing batteries.

Aesthetics

To make the fuzz box presentable so that students would want to manipulate the various parameters, we had to come up with an almost retail-worthy design. The layout first came up with symmetric properties in order to please the eye. Some of the electronic stage sequences were compromised in order to have the single-pull-single throw switches in the appropriate areas. The on/off switch was housed almost directly in the center so that as many possible knobs as possible protected it. This is appealing to the musician because the switch is less likely to turn on and waste the power supply during transportation. The option of what to do with the metal surface is left up to the individual fuzz box producer. The original Dr. Strangefuzz

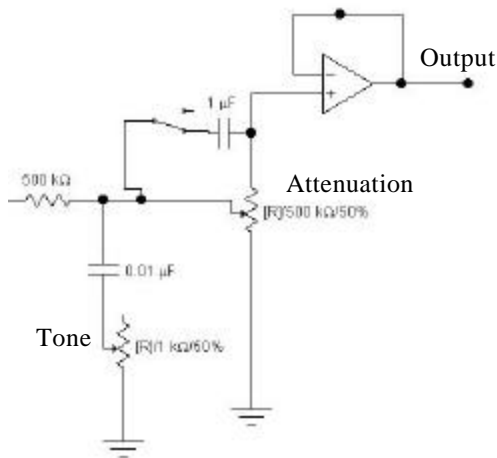

Fig. 6 – Tone and Attenuation Stage

The last stage of the fuzz box performs necessary tasks of tone control and attenuation of the signal. A 500 k Ω resistor first reduces the signal. The first pot forms a high pass filter in conjunction with the 0.01 μ F capacitor, which has the effect of removing higher frequency harmonics from the output. The next pot is basically a volume pot that attenuates the signal. There is a small capacitance within this pot that can reduce the upper frequency harmonic content of the signal, so we provide a switched capacitor across the pot to preserve this harmonic content. Finally, we come to an output buffer, which is a unity gain op amp in the non-inverting configuration. This signal then passed to a guitar amplifier.

Whole Circuit

When the various stages are combined, the end result is an analog signal processor. We invert the signal once in the circuit, the output is not in phase with the input. This is because there was trouble with feedback through the stomp switch in a previous version that did preserve phase. There is some flexibility in the exact values of resistors and capacitors. Power is provided by two 9 V batteries connected in series, taking the center of this configuration as ground to provide ± 9 V to the circuit. The complete schematic of the circuit is at the end of the report.

was intended to sport a black velvet fabric on the outside. Time limitations forced us to use a “Stone-Creations” spray paint by Rustoleum which made the fuzz box look as if composed of stone, and then chiseled.

VII. RESULTS AND ANALYSIS

Unfortunately, there is no way to convey the most important results on paper, but there are certain qualitative measurements that can be made. To this end, a few devices are used. To generate current to voltage (I-V) graphs of our diode loops, a program was written to be used in conjunction with a PC data acquisition card. In order to see the harmonic content of the output of Dr. Strangefuzz, a HP signal analyzer was used. This device basically gives a Fourier decomposition of a signal, so we can see the harmonic content directly. The signal analyzer is set to a range of 0 – 20 kHz and the harmonic content is displayed on a dBV scale, with the actual waveform shown below. A function generator provided a sine wave input signal at 1 kHz and with amplitude of 100 mV. Some commentary on the “sound” will also be made. The data for this commentary was gathered with a guitar and amp.

Diode plots and harmonic analysis

In order to see effect of changing diodes in the fuzz box, the drive is turned all the way up and everything else all the way down except for the volume.

The two diode loops chosen for analysis were the red LEDs and the 1N60s, mostly because they have very different I-V curves, shown below.

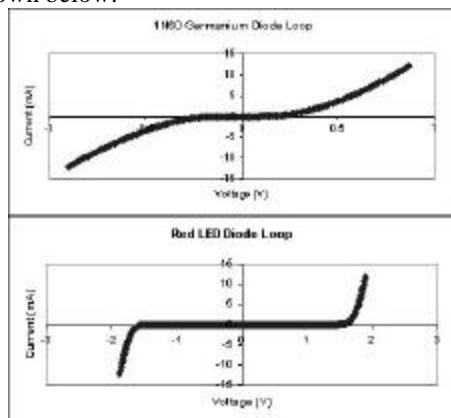

**Fig. 7 – Top 1N60 Loop I-V Curve
Bottom Red LED Loop I-V Curve**

The red LED has a very steep turn on at around 1.7 V, while the 1N60 gradually slopes up. The plots of the harmonic content of signals are below.

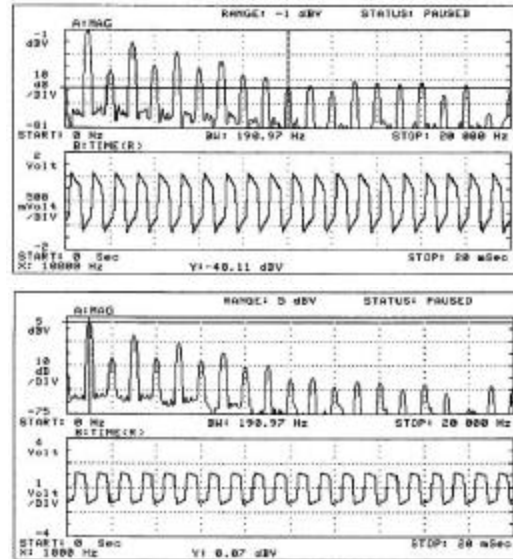

**Fig. 8 – Top Harmonic Content with 1N60
Bottom Harmonic Content with red LED**

Notice that there is much more content with the 1N60 in the upper frequencies, while the red LED produces lower content. This is quite noticeable in terms of sound as well. The 1N60 has a bright sound. It sounds similar to an older tube amp being overdriven. The red LED has a darker, bassier sound that works well with power chords. The LED loop was also considerably louder, which make sense considering the higher turn on voltage of the LEDs.

It should be noted that since there are two diode selector switches, combinations of different diodes are possible. This results in asymmetric clipping.

Other parameters and harmonic analysis

To isolate the effects of other parameters, the red LEDs were used in all cases while the parameter under consideration was varied. No plots were made of the effect of bias on the output, mostly because as the drive was increased the bias did less and less. The reason for this is as of yet unknown, but an RC time constant is likely to blame. The lower part of Fig. 8 provides the baseline for comparison. To maintain logical clarity, the plots will be considered in the order they appear in the signal chain.

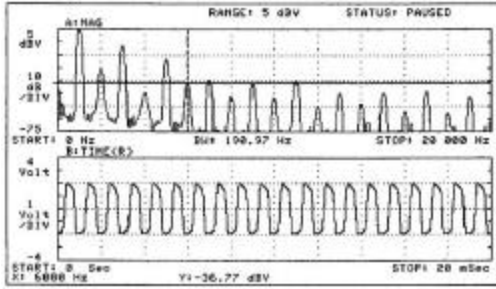
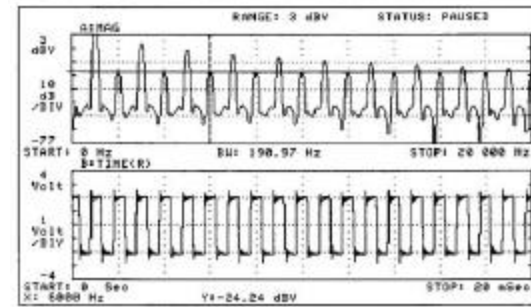
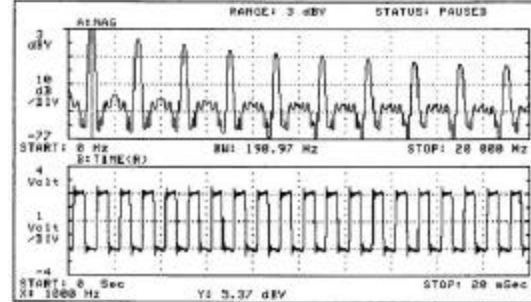

Fig. 9 – Demonstration of compliance pot

The compliance pot basically acts as current limiter for the diode loop. Here the drive, volume, and compliance are turned all the way up. The output with compliance is larger than without. This is because less signal is lost through the diodes due to the current limiting effect. Also, the waveform with compliance is more rounded. This arrangement sounds quite a bit less distorted and more bassy, and is also louder than without compliance.



**Fig. 11 – Demonstration of op amp overdrive
Top without drive, bottom with drive**

Without driving the diodes at all, it is possible to overdrive the op amp in the boost section by increasing the gain to the point where the output goes the full ± 9 V. The effect is similar to diode distortion in that it produces square waves, but has a distinct sound. In the above plot, both the load and boost are maxed out. This produces almost exclusively odd harmonics, and sounds distorted but somewhat hollow and dry. However, when the drive is turned up, which adds diode clipping to the fray, even harmonics are produced. The sound with this arrangement is heavily distorted, very compressed, and somewhat noisy.

Unfortunately, there is no evidence of current limiting, even with the load all the way up. It is probable that the op amp is capable of putting out more current than was thought.

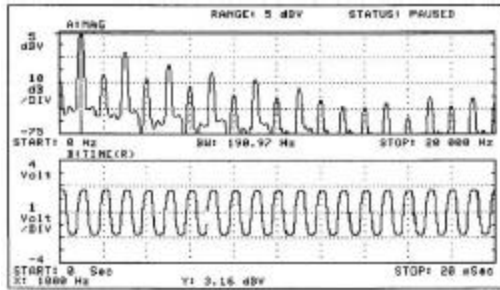

**Fig. 10 – Demonstration of compliance pot
and compliance switch**

Here we have a plot that shows the effect of the compliance switch. This switch connects a capacitor to ground across the compliance pot, providing a route to ground for higher frequency content, removing it from the signal. This reduces the overall output and produces a further rounding of the waveform. Soundwise, the switch adds a bit of bass, but has no major effect. Luckily, the capacitor is easily changed, so experimentation to increase the effect of this component is easy.

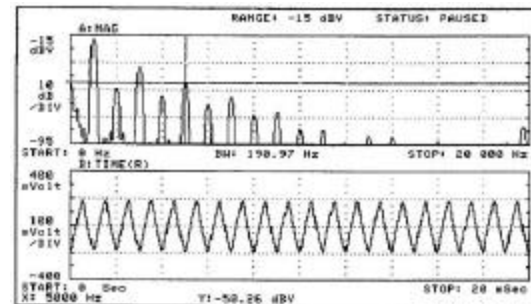

Fig. 12 – Demonstration of tone control

Here we have the drive control maxed out, and all others fully down. Notice the reduction of higher harmonic content and the nearly sawtooth waveform. The sawtooth is due to the integrating effect of the tone control. The sound with this configuration is what is expected: bassy, muffled, and mostly unpleasant. The user will not want to turn the tone control all the way down.

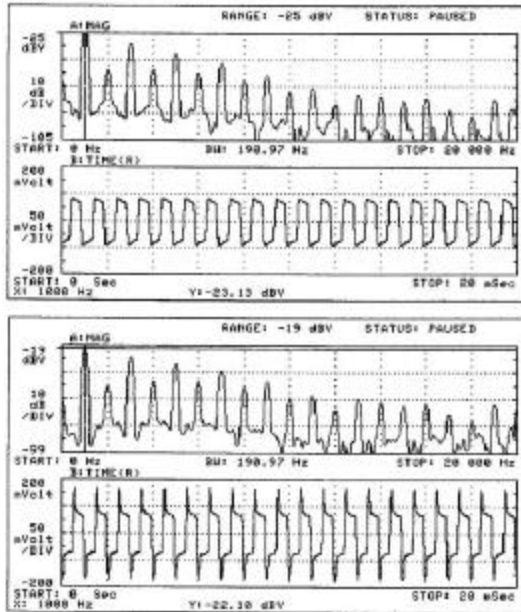

Fig. 13 – Bright switch demo
Top without bright, bottom with bright

To show the effect of the bright switch, the volume must be reduced. The reason for the bright switch is that there is a small capacitance in the attenuation pot that can reduce the high frequency content of the signal. To combat this, the capacitor is placed across the pot, allowing higher frequencies to pass. The difference in harmonic content is most evident in comparing the actual waveforms of the two configurations. The difference soundwise ranges from very subtle if the volume is most of the way up to quite noticeable when the volume is down.

VIII. SUMMARY

There is always more work to be done with things like this. Years could be spent tweaking values and suchlike. Future revisions of Dr. Strangefuzz should deal with a few problems that were encountered. Modification of the bias setup would allow for asymmetric clipping, even with two of the same diode. Experimenting with the compliance capacitor may produce more of an effect as well. The lack of current limiting in the boost section may be remedied by changing resistor values.

