

Please note that the links in the PEARL logotype above are “live” and can be used to direct your web browser to our site or to open an e-mail message window addressed to ourselves.

To view our item listings on eBay, [click here](#).

To see the feedback we have left for our customers, [click here](#).

This document has been prepared as a public service . Any and all trademarks and logotypes used herein are the property of their owners.

It is our intent to provide this document in accordance with the stipulations with respect to “fair use” as delineated in Copyrights - Chapter 1: Subject Matter and Scope of Copyright; Sec. 107. Limitations on exclusive rights: Fair Use.

Public access to copy of this document is provided on the website of Cornell Law School (<http://www4.law.cornell.edu/uscode/17/107.html>) and is here reproduced below:

Sec. 107. - Limitations on exclusive rights: Fair Use

Notwithstanding the provisions of sections 106 and 106A, the fair use of a copyrighted work, including such use by reproduction in copies or phonorecords or by any other means specified by that section, for purposes such as criticism, comment, news reporting, teaching (including multiple copies for classroom use), scholarship, or research, is not an infringement of copyright. In determining whether the use made of a work in any particular case is a fair use the factors to be considered shall include:

- 1 - the purpose and character of the use, including whether such use is of a commercial nature or is for nonprofit educational purposes;
- 2 - the nature of the copyrighted work;
- 3 - the amount and substantiality of the portion used in relation to the copyrighted work as a whole; and
- 4 - the effect of the use upon the potential market for or value of the copyrighted work.

The fact that a work is unpublished shall not itself bar a finding of fair use if such finding is made upon consideration of all the above factors

Quad Electrostatic Loudspeaker

Service Data—Model ESL 57

General

The notes in this section are for the guidance of the engineer who has some experience of carrying out repairs to these speakers together with the necessary proper materials for the repair.

The QUAD electrostatic speaker consists of five components: two bass units, one treble unit, an audio transformer unit and an EHT supply unit. If any repairs are necessary, it should be ascertained which of the five components is the cause and that component should be either replaced complete or repaired as appropriate.



Fault Diagnosis

Loss of Sensitivity

Check the EHT voltage, which should be: Bass 6Kv + 7%; Treble 1.5Kv + 7%.

If low, check, by disconnecting, whether due to leakage in speaker unit or fault within EHT unit. Voltages must be checked only with electrostatic meters, as the current drawn by other types may itself damage the rectifiers.

Distortion

1. Make sure that the speaker is really at fault by comparison with a second electrostatic speaker, using a QUAD amplifier.

2. Check EHT voltage.

3. Suspect intermittent breakdown in speaker units.
4. Suspect intermittent breakdown in audio transformer unit. (Note: a fault in this unit is very unlikely).

No Output at All

Suspect EHT unit or audio transformer unit after checking more obvious things like external connections, not forgetting the leads under the transformer unit connecting the input sockets.

Background Noise

One cause of background noise in the electrostatic loudspeaker is internal discharge of the EHT supply at times of high humidity, or high voltage, or both. This may be reduced by lowering the EHT voltage and a tap is provided on the EHT mains transformer for this purpose.

Before the EHT unit is touched the mains should be completely disconnected and the loudspeaker left to stand for two hours to ensure it is completely discharged.

The connections to the EHT rectifier block are normally taken from tags marked Common and 61 0V. The latter is the righthand end tag and next to it is a blank tag marked 590V to which should be transferred the lead normally connected to the 61 0V tag. Background noise may also be caused by discharge of the EHT from points external to the loudspeaker units, at the tags on the rectifier block for example, if a hair of felt or piece of fluff comes in reasonably close proximity to that point, or if a spike of solder or sharp point of wire permits corona discharge.

Where EHT leakage occurs via a bass unit, this is sometimes found to be discharging from one of the eyelets around the periphery of the bass unit plates, probably to one of the aluminium brackets. In such cases a satisfactory repair can be effected by slitting the polythene tape round the edges of the unit, opening the dustcover frames and insulating the leak by applying a single layer of similar polythene tape all round the periphery of the internal plates, on top of the existing sealing tape, and reassembling the dustcovers, again with polythene tape.

Other internal failures of insulation will probably necessitate replacing the loudspeaker unit affected.

Mechanical

If the dust seal covers should be torn, it may be necessary to replace the complete unit as there will have been ingress of dust, which causes loss of sensitivity of the unit concerned.

Dismantling the Speaker

The loudspeaker should be switched off for about two hours before the grilles are removed, so as to ensure the EHT unit has completely discharged.

The component loudspeaker units of the QUAD electrostatic loudspeaker must be handled with the utmost care, partly because when not supported by the rigid frame of the cabinet they are more liable to physical distortion which would reduce the small internal clearances, and partly because the dust covers are necessarily made of very thin and therefore fragile plastic film.

At the rear of the treble unit are four pins located in the wooden struts of the cabinet, and as these represent an additional hazard to the dust covers of the treble unit, the positioning of this unit requires particular care.

Soldered joints should be smoothed and rounded and all spikes of solder, wisps of wire, etc., removed as these would tend to cause arcing at the high internal voltages used.

Removing Front and Rear Expanded Metal Grilles

The rear grille is held only by the screws around its periphery. For the front grille it is necessary first to remove the side mouldings, the staples through the metal beneath them, and the screws under the baseboard. Then the bottom edge of the grille is lifted gently outwards and upwards until the top rear edge may be slipped out of its groove in the cabinet, when the whole grille will be free. Care must be taken not to strain the top curved section during removal or the metal may split.

Replacing the Front Grille

Replacement grilles are normally supplied cut and partly preformed so the procedure is as for refitting an existing grille. It may be found helpful when working single handed, having inserted the top back edge of the sheet into the slot in the cabinet, to hold the bottom edge of the grille under slight tension to the bottom of the wooden frame by means of elastic bands and simple hooks of wire, such as an opened paperclip, and then to use a bar of wood slightly longer than the width of the sheet, and with a good flat face, to bed the grille to the frame by moving the bar progressively down the face of the grille, tacking the sides as you go, finally securing the bottom edge with the screws removed from the old grille. Do not forget to fasten the earthing lead to the grille.

Replacing Bass and Treble Units

1. Remove both grilles.
2. Remove the top and bottom aluminium brackets in front of the centre (treble) unit.
3. If the treble unit is to be replaced, it should now be disconnected from the audio transformer (the large rectangular can on the left-hand side when viewed from the rear). This is held in position solely by four screws whose heads are accessible below the baseboard of the speaker. If the speaker is tilted to provide access to slacken these screws it must be restored to its upright position before they are removed or the transformer will have no support other than its connecting wires.
4. Carefully prise out one bass unit and slide it past the front of the treble unit until the outer edge clears the remaining bracket at top and bottom of the cabinet.
5. Either disconnect and remove the bass unit if this has to be replaced or move it far enough to enable access to be obtained to the treble unit, as required. To remove the treble unit ensure it is free of the four pins mentioned on page 2, then slide it sideways into the space vacated by the bass unit already moved, and lift it out.

EHT and Audio Transformer Units

Only the rear grille need be removed to provide access to these units. Both are secured by screws through the base board only and if the speaker is tilted to obtain access to these screwheads it must be restored to the upright position before the screws are removed or the unit will have no support other than its connecting wires.

Place a sheet of cardboard behind the unit to be worked on to protect the thin plastic dustcover of the bass unit from accidental damage due to specks of solder or wire ends, etc.

Note and mark the flexible connections to the unit to be worked on so as to ensure correct reconnection.

To replace the rectifier block of the EHT unit, undo the two 4BA nuts securing it to the framework of the EHT unit and remove it. If the replacement block is found to be of a different type, it will still be electrically and physically interchangeable with the earlier type, and the equivalent connections are shown in Fig. 1. If the leads to the loudspeaker units have to be extended, the joints should be insulated with high voltage sleeving and staggered so that two joints do not lie together.

To remove the Audio Transformer, after having removed the four securing screws, invert the transformer and unsolder the wires.

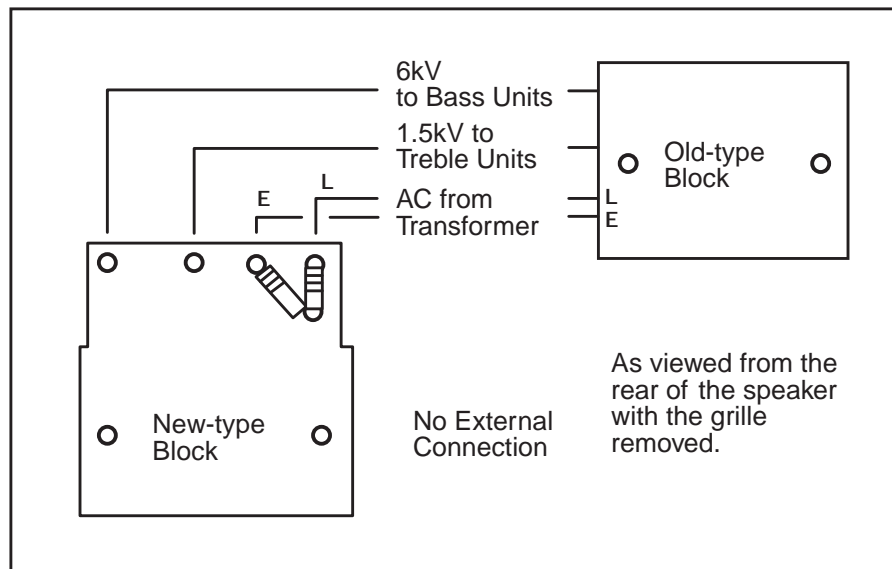

Fig. 1

Reassembling the Speaker

To reassemble, the dismantling procedure is reversed, but in addition it will be necessary to remove any wrinkles which may have appeared in the treble unit's front and rear dust covers, as these will produce audible rattles when the speaker is in use. This is achieved by means of gentle heat which thermosets the plastic film, and may most conveniently be applied by means of a small warm air blower, such as a hand-held dryer. The nozzle should be held about

25mm from the dust cover and moved up and down the unit as uniformly as possible at a speed of about 75mm per second, in regular lines so as to cover the whole area. Repeat until all wrinkles have disappeared, but always treat the whole area and do not tackle individual wrinkles separately. A certain amount of skill is required in this operation. Obviously if the nozzle is not close enough and/or the speed of travel too great, there will not be enough heat to affect the cover. On the other hand too much heat at one point can quickly burn a hole. When carrying out this process for the first time, progressively reduce the distance and speed until the desired results are obtained.

Heat should not be applied to the bass unit covers. Any slight wrinkles in these covers will rarely have any audible effect and will in any case normally disappear as the tensions even themselves out in a few days.

After thermosetting the treble unit dust covers, the damping felts behind the treble unit must be stretched and fixed so that there is no contact between them and the treble dust cover, as this will also affect reproduction.

Fitting New Dust Covers

Note: The plates and dust cover material acquire a static charge and if placed in a dusty atmosphere or near any accumulation of dust it will adhere to them, with deleterious effects. Only plastic film supplied by Acoustical should be used. Specify whether for bass or treble unit when ordering.

First remove the faulty unit from speaker as described on page 2 and strip the adhesive tape from around its edges to release the two dustcover frames. On bass units, carefully disconnect the three wires from the terminal board, having noted their positions, and remove the board. Clean all loose dustcover material from the wooden frames since any pieces left to flap will buzz.

If the bass or treble unit is to be left without dustcovers for any length of time, it should be kept in a dust free environment.

Spread enough of the new dust cover material on to any clean, solid, flat surface to leave about 150 mm surplus all around the frame, and hold in position with pieces of adhesive tape at each corner and at intervals along the sides as required.

The materials should not be over stretched but just tightly enough to remove the wrinkles.

Adhesive can now be applied to the frame, the frame placed into position on the material and left to dry. The adhesive should preferably be of a type which does not set brittle, such as Samuel Jones' Samson C203, Evostick, etc. When this is dry, use a razor blade to trim off all surplus cover material back to the edge of the frame. The holes to the terminals should be BURNT through the film with a small soldering iron. If pierced cold the material will in time split and run the whole length of the dust cover.

When a pair of covers have been made, the unit and the covers should be blown with a jet of dry air to remove any dust particles etc., which have adhered to them, as this will cause a loss in sensitivity.

GREAT care should be taken if it is found necessary to renew any soldered joints on the plates. Anything more than a quick touch to the tags will soften the plate material and loosen the solder tag. A heat sink is helpful here.

When reconnecting to the terminals be sure not to cross wires as this will result in the failure of the speaker to work.

The unit should be replaced between the two frames and sealed with 50mm wide polythene adhesive tape all around the outside edge of the frames as before.

This completes the recovering and the unit can now be reassembled into position in the speaker.

Modifications

1. At serial number 16800 (March 1966) additional filtering was added to protect the treble unit from damage due to high level low frequency signals. Earlier speakers may be modified as described below, when they are to be used with the Quad 303 or other suitable amplifiers of comparable output.

The components required can be obtained ready assembled on a tagboard, if required, and Fig.2 shows this in position under the audio transformer. Alternatively, suitable resistors and capacitors from normal servicing stocks, may be used if preferred.

Fig. 3 shows the tagboard layout from serial number 16800 onwards.

Modification procedure for loudspeakers earlier than serial number 16800 when used with the Quad 303 amplifier.

- (a) Remove the AC supply from the speaker and allow two hours for the EHT to discharge.
- (b) Undo the screws all around the periphery of the rear grille and remove the grille.
- (c) Tilt the loudspeaker to permit access to the underside of the baseboard, taking care not to dent the front grille.
- (d) Remove the four screws holding the audio transformer (large can on the left hand side) in place, remembering to support the transformer before it is freed or it may slip and damage the left hand bass unit dustcover.
- (e) Restore the speaker to an upright position and invert the audio transformer, taking care not to strain its external wiring.
- (f) Remove the two drive screws on the right hand side of the tagboard and use these to secure the small tag-

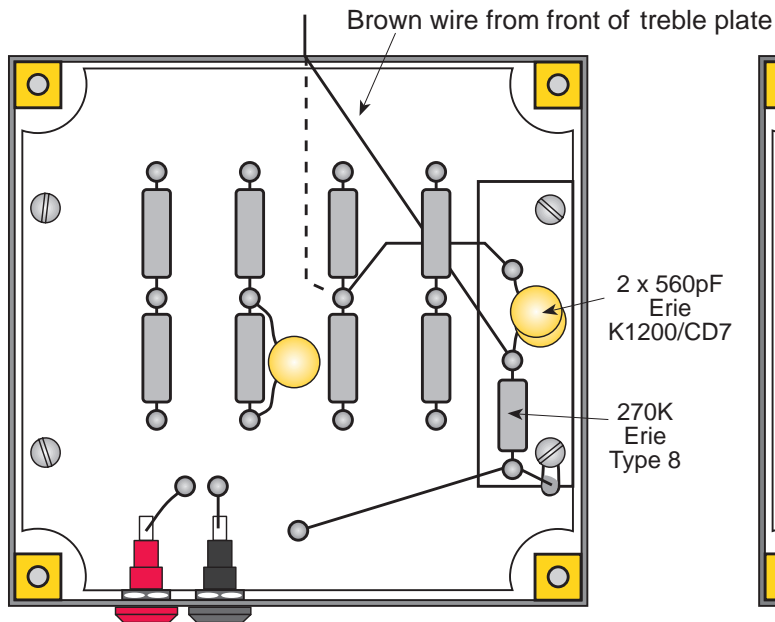

Fig. 2

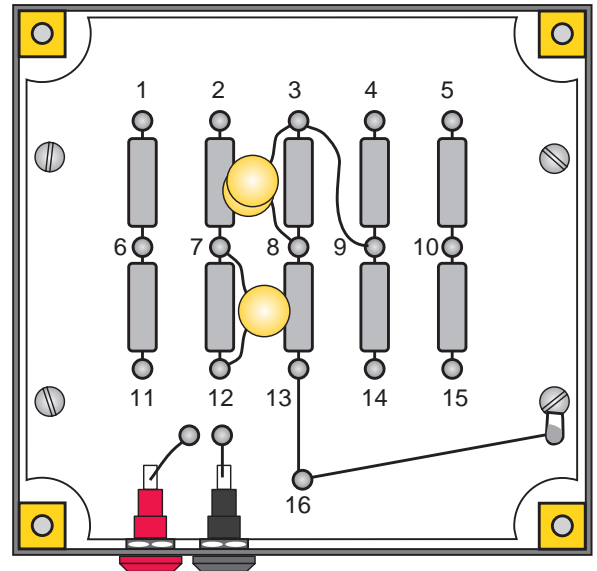

Fig. 3

board supplied,
as shown in fig. 2.

(g) Rewire as shown, ensuring that the brown lead which has to be stretched to reach its new anchor point does not press against any sharp edges of turret lugs or solder.

(h) Reassemble the speaker in the reverse order of operations (a) to (e).

2. Voltage selector and voltage selector socket changed.

Old types no longer available. New type Stock No's. Selector- SV5049A. Select. skt. SVB9AAA.

The two types are not interchangeable.

3. At Serial No. 44000 the A.C. supply voltage plug and socket changed.

Stock No's. ESL up to Serial No. 44000, plug - PP1403A, socket- PS18621.

Stock No's. ESL after Serial No. 44,000, plug - PPP579A, socket- PSP587A.

4. At Serial No. 45590 supply indicator neon changed.

Stock No's. ESL up to Serial No. 45590- BNSL50R.

Stock No's. ESL after Serial No. 45590- BNT430R.

The two types are not interchangeable.

COMPONENTS LIST

Components and circuit detail may vary slightly depending on the age of the equipment. In case of doubt please refer the query to Acoustical.

Assembly Oelsprs E/Speaker components list

Part No. Description

BNSL50R Neon SL50 Red
BNT430R Neon Type T430 Red
PP1403A Plug 3 pin AC SA1403
PP579A Plug 3 pin AC Euro
PP378A0 Plug L378A 4 Black 4mm
PP378A2 Plug L378A 4 Red 4mm
PS13180 Socket 4mm L1318 Black panel
PS 13182 Socket 4 mm L 1318 Red panel
PS18621 Cable end skt 3 pin AC
PSP587A Skt P587 AC cable

QELBAPA Quad ESL bass unit
QELCONA ESL mod. kit

QELES1 B ESL aluminium bracket
QELFGPK ESLfrontgrille-Black
QELFGPZ ESLfrontgrille-Bronze
QELHTPA ESL EHT unit
QELHTPC ESL EHT unit - Canada
QELHTPS ESL EHT unit - Sweden
QELHTTD EHT unit Demko
QELLAPA ESL audio transf.
QELLEGA ESL legs set

QELLMPA ESL AC supply transf.
QELREPA ESL rectifier block
QELRGPA ESLreargrille
QELSIPA ESL side rails
QELTRPA ESLtrebleunit
SV5049A Voltage selector T5049
SVB9AAA Voltage selector skt
EFMY06A Treble unit dustcover material

M11078A Treble unit dustcover frame
EFSA50A Bass unit dustcover material
M11079A Bass unit dustcover frame
I BELBAA Bass unit terminal board
FP2630A Bass unit terminal
C560PMI Capacitor 560pF
R150KKA Resistor150K10%Type 8
R180KJB Resistor180K5%Type 8
R270KKA Resistor 270K 10% Type 8
IP1401 B Polythene tape 50mm

Use on ESL up to
Serial No.44000
Use on ESL after Serial
No.44000

Round AC input connector use on ESL up to Serial
No's.44000 Use on ESL Serial No.44000 and over

Fit to speakers Serial No.16800 and below when
used with amplifiers of greater output than the Quad II