

**ENGINE SECTION 1**

This service manual has been prepared to provide SUBARU service personnel with the necessary information and data for the correct maintenance and repair of SUBARU vehicles.

This manual includes the procedures for maintenance, disassembling, reassembling, inspection and adjustment of components and diagnostics for guidance of experienced mechanics.

Please peruse and utilize this manual fully to ensure complete repair work for satisfying our customers by keeping their vehicle in optimum condition. When replacement of parts during repair work is needed, be sure to use SUBARU genuine parts.

All information, illustration and specifications contained in this manual are based on the latest product information available at the time of publication approval.

**FUEL INJECTION (FUEL SYSTEMS) FU(H4SO)**

**EMISSION CONTROL (AUX. EMISSION CONTROL DEVICES) EC(H4SO)**

**INTAKE (INDUCTION) IN(H4SO)**

**MECHANICAL ME(H4SO)**

**EXHAUST EX(H4SO)**

**COOLING CO(H4SO)**

**LUBRICATION LU(H4SO)**

**SPEED CONTROL SYSTEMS SP(H4SO)**

**IGNITION IG(H4SO)**

**STARTING/CHARGING SYSTEMS SC(H4SO)**

**ENGINE (DIAGNOSTICS) EN(H4SO)(diag)**

**FUEL INJECTION (FUEL SYSTEMS) FU(H4SOw/oOBD)**

**EMISSION CONTROL (AUX. EMISSION CONTROL DEVICES) EC(H4SOw/oOBD)**

**INTAKE (INDUCTION) IN(H4SOw/oOBD)**

**MECHANICAL ME(H4SOw/oOBD)**

**EXHAUST EX(H4SOw/oOBD)**

**COOLING CO(H4SOw/oOBD)**

ENGINE SECTION 1

LUBRICATION

LU(H4SOw/oOBD)

SPEED CONTROL SYSTEMS

SP(H4SOw/oOBD)

IGNITION

IG(H4SOw/oOBD)

STARTING/CHARGING SYSTEMS

SC(H4SOw/oOBD)

ENGINE (DIAGNOSTICS)

EN(H4SOw/oOBD)  
(diag)

# FUEL INJECTION (FUEL SYSTEMS)

# *FU(H4S0w/oOBD)*

---

	<b>Page</b>
1. General Description .....	2
2. Throttle Body .....	15
3. Intake Manifold .....	16
4. Engine Coolant Temperature Sensor.....	28
5. Crankshaft Position Sensor.....	29
6. Camshaft Position Sensor.....	30
7. Knock Sensor .....	31
8. Throttle Position Sensor .....	32
9. Intake Air Temperature and Manifold Absolute Pressure Sensor .....	34
10. Idle Air Control Solenoid Valve .....	35
11. Fuel Injector .....	36
12. Oxygen Sensor .....	41
13. Engine Control Module (ECM) .....	43
14. Main Relay .....	44
15. Fuel Pump Relay.....	45
16. Fuel .....	46
17. Fuel Tank .....	47
18. Fuel Filler Pipe .....	50
19. Fuel Pump .....	54
20. Fuel Level Sensor .....	57
21. Fuel Sub Level Sensor.....	58
22. Fuel Filter .....	59
23. Fuel Cut Valve.....	60
24. Fuel Damper Valve .....	61
25. Fuel Delivery, Return and Evaporation Lines.....	62
26. Fuel System Trouble in General .....	65

# Fuel Injector

## FUEL INJECTION (FUEL SYSTEMS)

### 11. Fuel Injector

#### A: REMOVAL

##### 1. RH SIDE

- 1) Release the fuel pressure.  
<Ref. to FU(H4SOw/oOBD)-46, RELEASING OF FUEL PRESSURE, OPERATION, Fuel.>
- 2) Open the fuel filler flap lid and remove the fuel filler cap.
- 3) Disconnect the ground cable from battery.

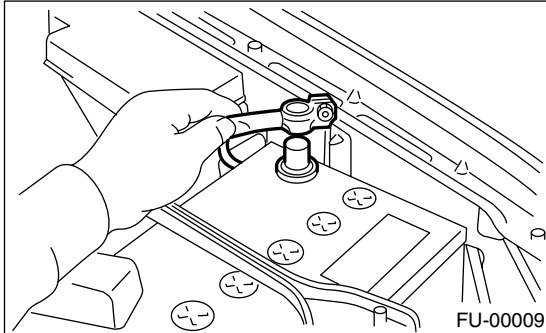

- 4) Remove the resonator chamber. <Ref. to IN(H4SO)-7, REMOVAL, Resonator Chamber.>
- 5) Remove the spark plug cords from spark plugs (#1 and #3 cylinders).

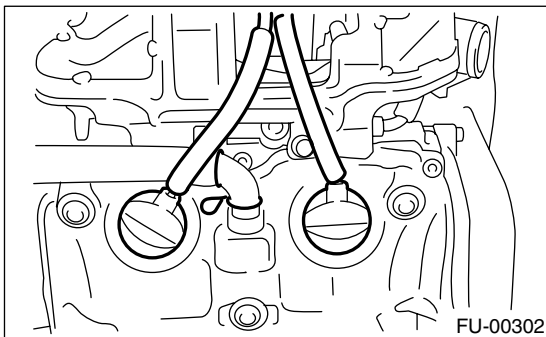

- 6) Remove the power steering pump and tank from brackets.

- (1) Remove the front side V-belt. <Ref. to ME(H4SO)-43, REMOVAL, V-belt.>
- (2) Remove the bolts which hold the power steering pipes onto intake manifold protector.

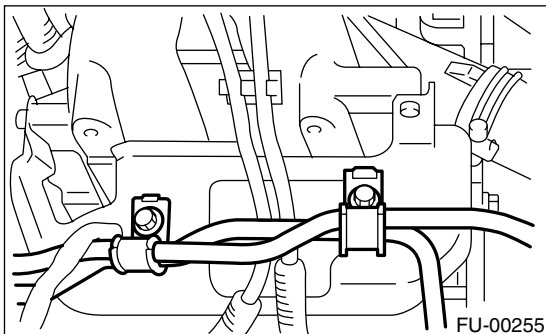

- (3) Remove the bolts which install the power steering pump to bracket.

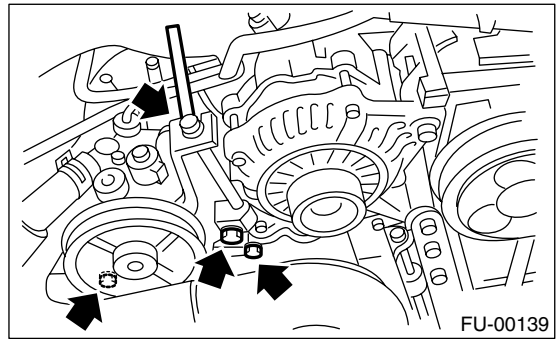

- (4) Disconnect the connector from power steering pump switch.

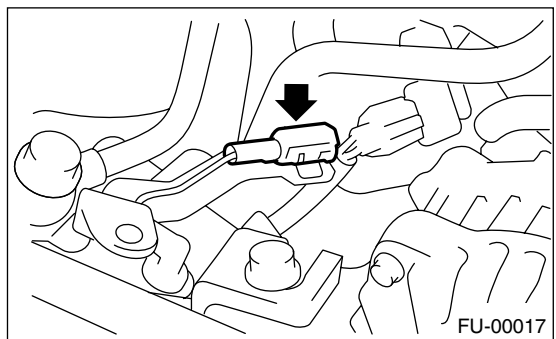

- (5) Remove the power steering tank from the bracket by pulling it upwards.

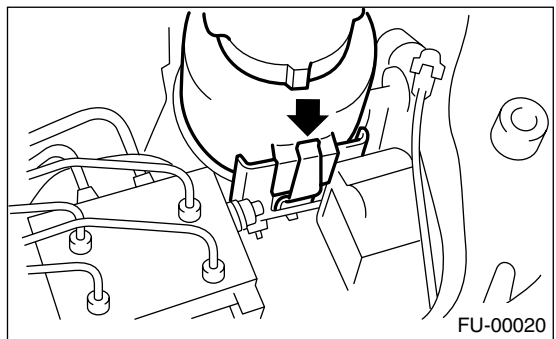

- (6) Place the power steering pump and tank on the right side wheel apron.

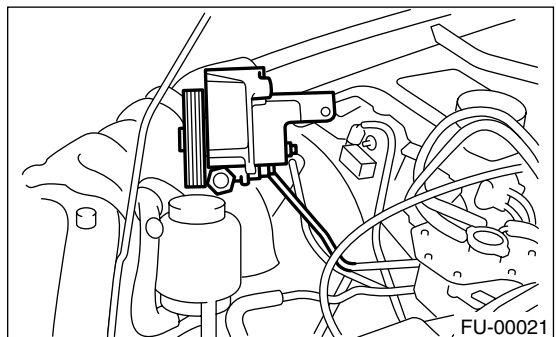

# Fuel Injector

7) Remove the fuel pipe protector RH.

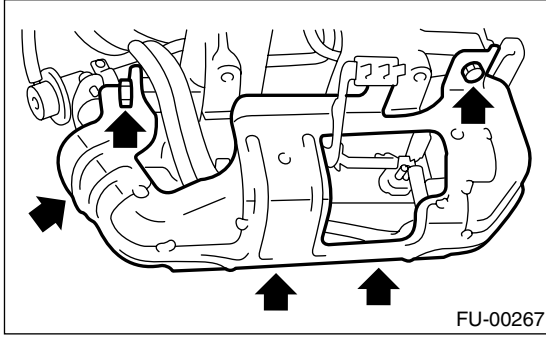

8) Disconnect the connector from fuel injector.

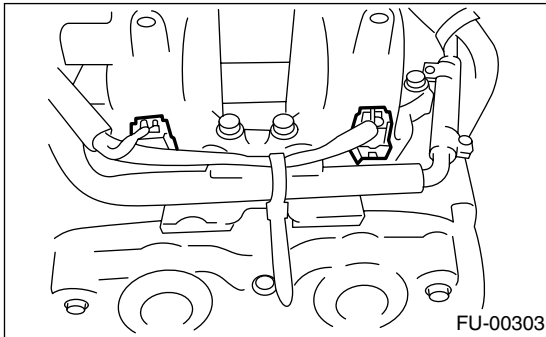

9) Remove the bolts which hold the fuel injector pipe to intake manifold.

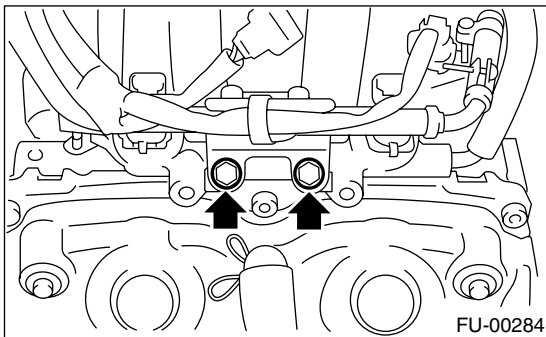
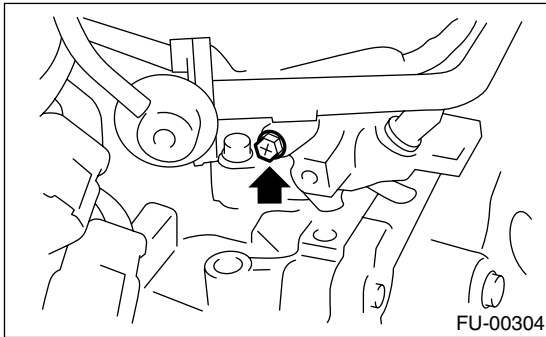

10) Remove the fuel injector from intake manifold.

(1) Remove the fuel injector securing clip.

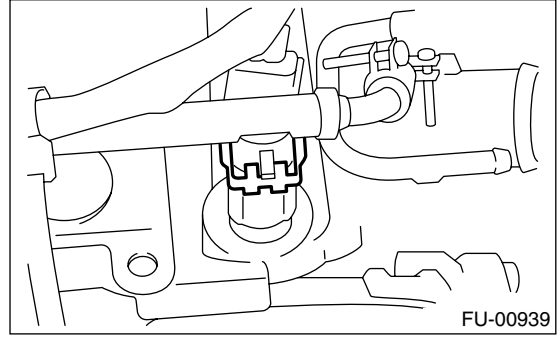

(2) Remove the fuel injector while lifting up the fuel injector pipe.

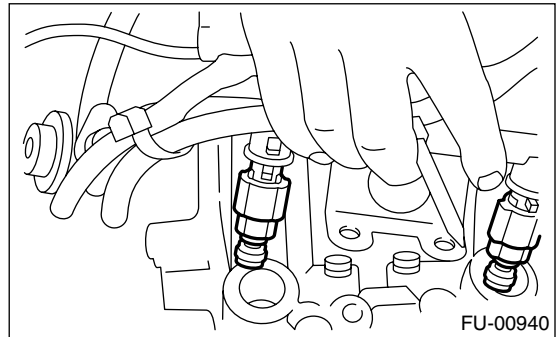

# Fuel Injector

## FUEL INJECTION (FUEL SYSTEMS)

### 2. LH SIDE

- 1) Release the fuel pressure. <Ref. to FU(H4S0w/oOBD)-46, RELEASING OF FUEL PRESSURE, OPERATION, Fuel.>
- 2) Open the fuel filler flap lid and remove the fuel filler cap.
- 3) Disconnect the ground cable from battery.

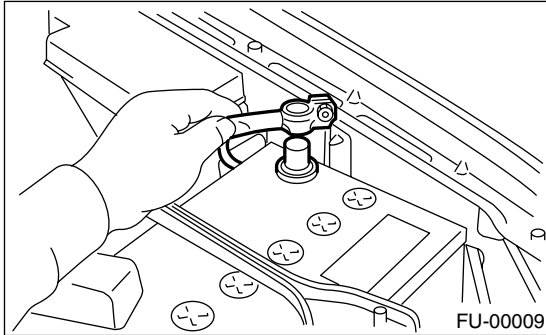

- 4) Remove the two bolts which install the washer tank on body.

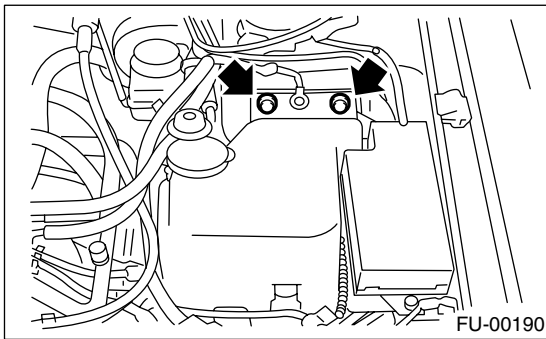

- 5) Disconnect the connector from front window washer motor.
- 6) Disconnect the connector from rear gate glass washer motor.

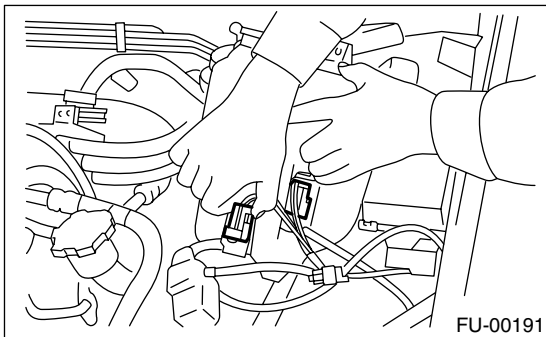

- 7) Disconnect the rear window glass washer hose from washer motor, and then plug the connection with a suitable cap.

- 8) Move the washer tank, and secure it away from working area.

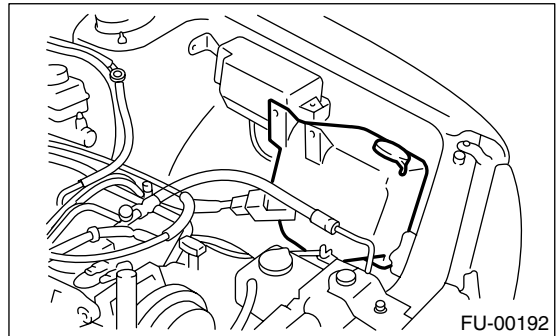

- 9) Remove the spark plug cords from spark plugs (#2 and #4 cylinders).

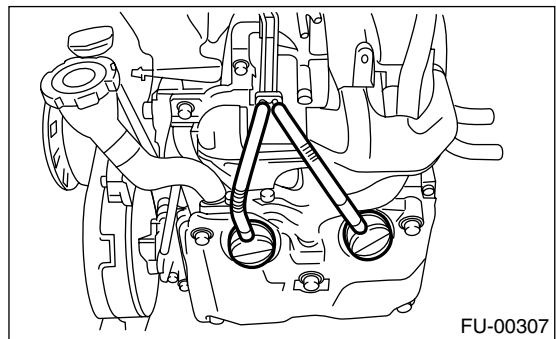

- 10) Remove the fuel pipe protector LH.

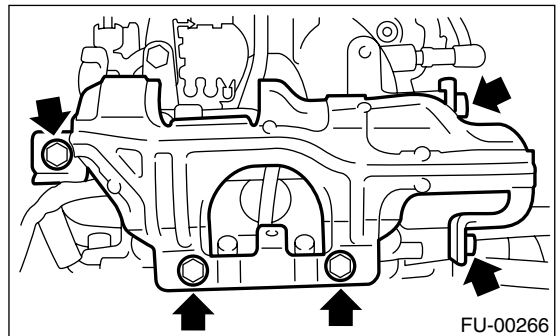

- 11) Disconnect the connector from fuel injector.

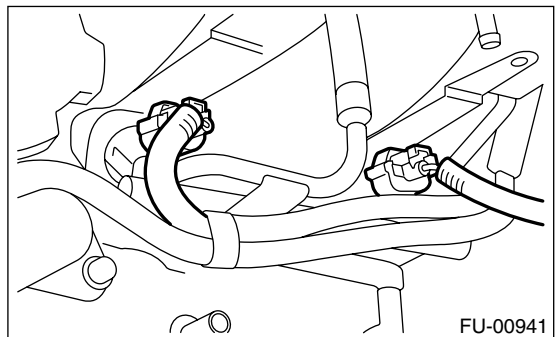

12) Remove the bolt which installs the fuel injector pipe to intake manifold.

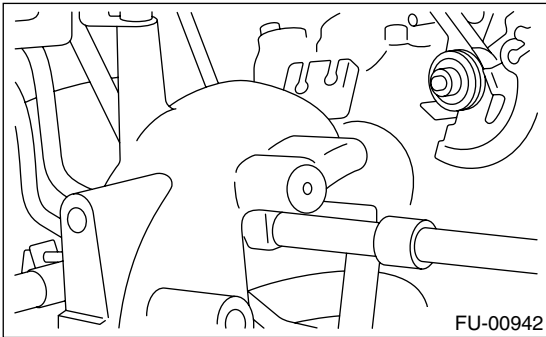
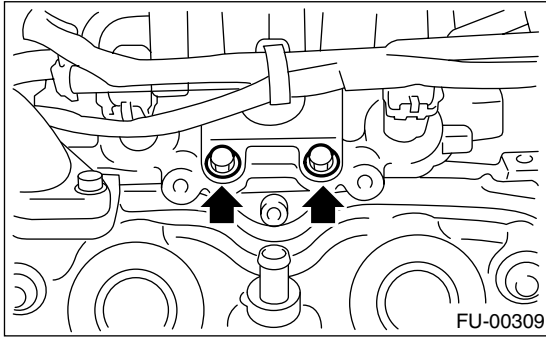

13) Remove the bolt which holds the fuel pipe on intake manifold.

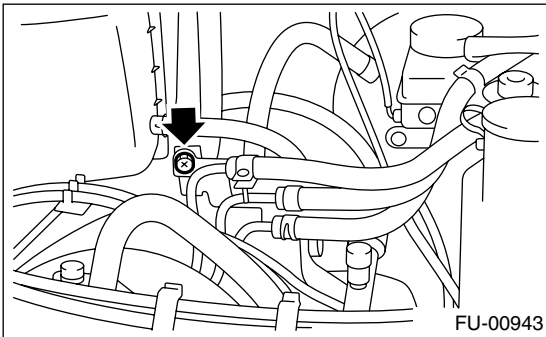

14) Remove the fuel injector from intake manifold.  
(1) Remove the fuel injector securing clip.

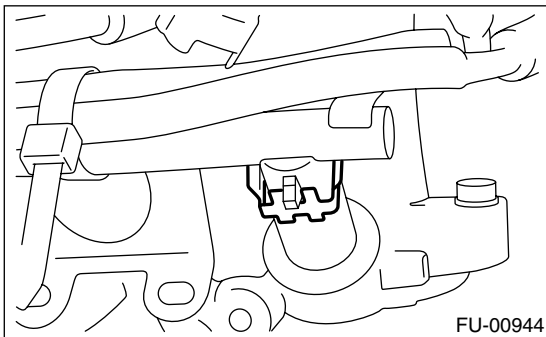

(2) Remove the fuel injector while lifting up the fuel injector pipe.

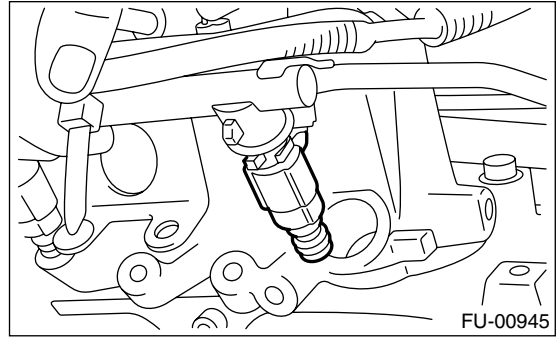

## B: INSTALLATION

### 1. RH SIDE

Install in the reverse order of removal.

#### NOTE:

Replace the O-rings with new ones.

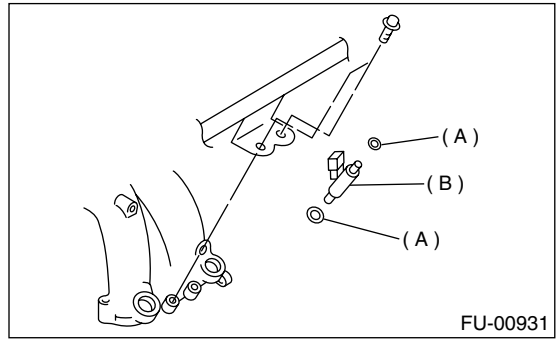

- (A) O-ring
- (B) Fuel injector

**Tightening torque:**  
**6.4 N·m (0.65 kgf-m, 4.7 ft-lb)**

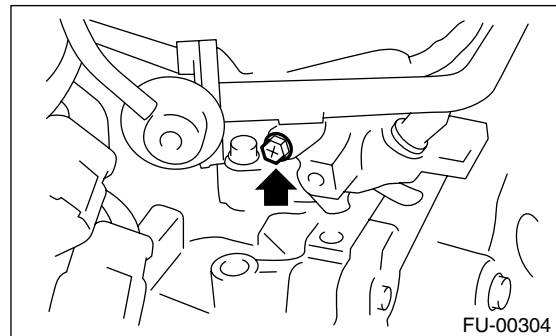

# Fuel Injector

## FUEL INJECTION (FUEL SYSTEMS)

**Tightening torque:**

**19 N·m (1.9 kgf·m, 14.0 ft·lb)**

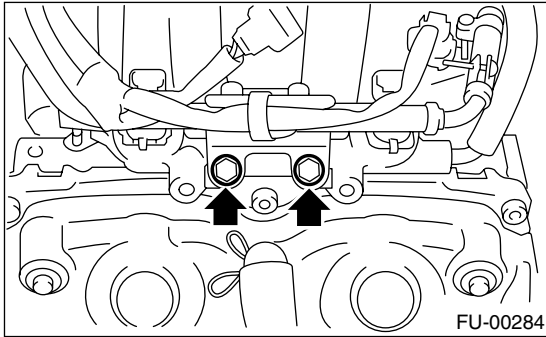

**Tightening torque:**

**6.4 N·m (0.65 kgf·m, 4.7 ft·lb)**

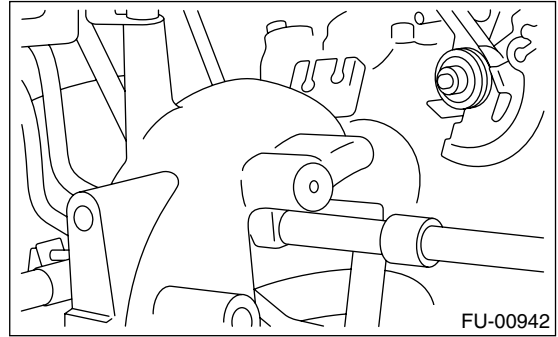

**Tightening torque:**

**19 N·m (1.9 kgf·m, 14.0 ft·lb)**

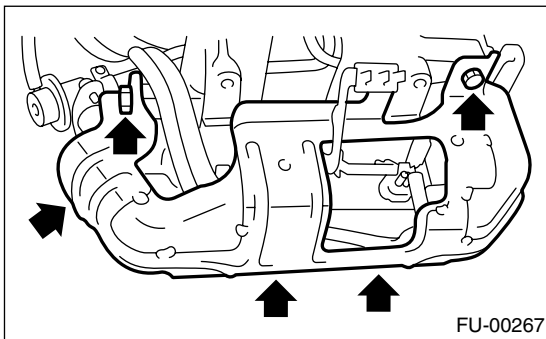

**Tightening torque:**

**6.4 N·m (0.65 kgf·m, 4.7 ft·lb)**

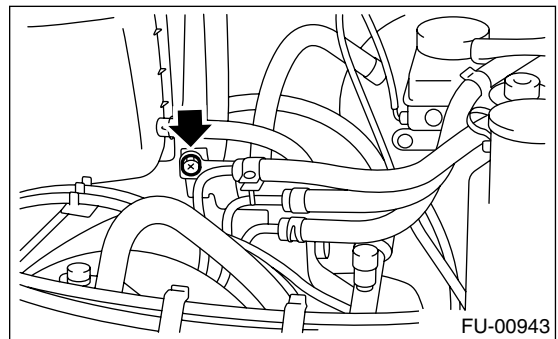

## 2. LH SIDE

Install in the reverse order of removal.

**NOTE:**

Replace the O-rings with new ones.

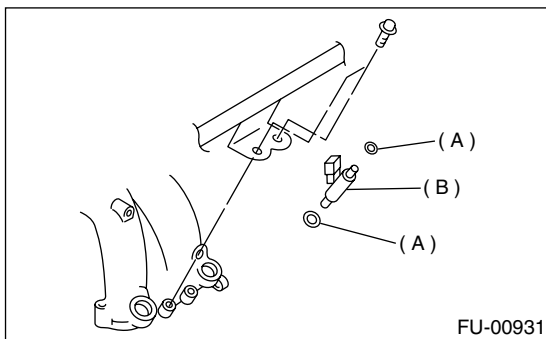

- (A) O-ring
- (B) Fuel injector

**Tightening torque:**

**19 N·m (1.9 kgf·m, 14.0 ft·lb)**

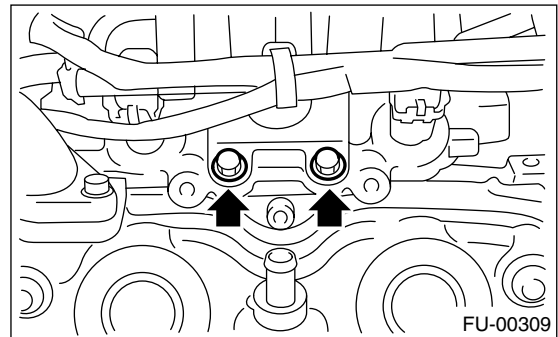

**Tightening torque:**

**19 N·m (1.9 kgf·m, 14.0 ft·lb)**

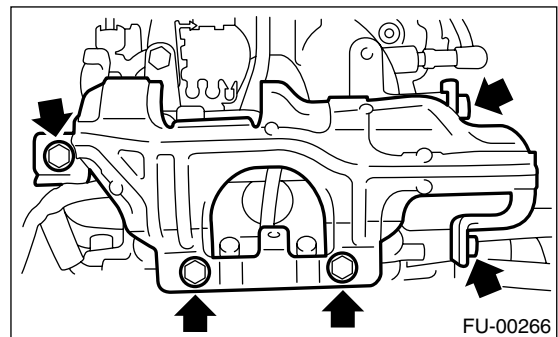



## 12. Oxygen Sensor

### A: REMOVAL

- 1) Disconnect the ground cable from battery.

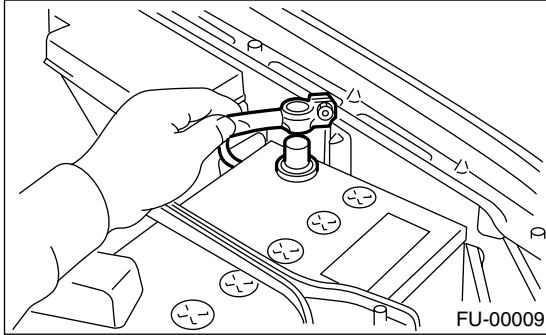

- 2) Disconnect the connector from oxygen sensor.

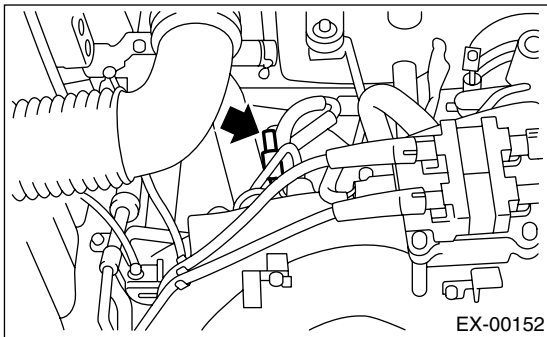

- 3) Lift-up the vehicle.
- 4) Apply a coat of spray type lubricant to the threaded portion of oxygen sensor, and leave it for 1 minute or more.
- 5) Remove the oxygen sensor.

### CAUTION:

When removing the oxygen sensor, wait until the exhaust pipe cools, otherwise it will damage exhaust pipe.

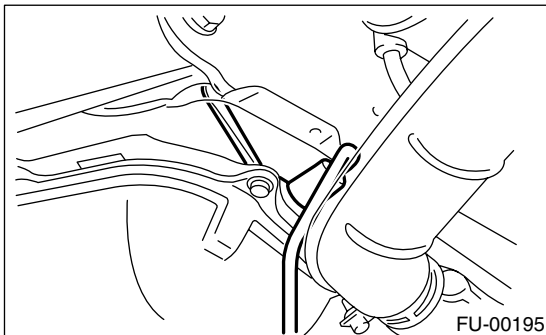

### B: INSTALLATION

- 1) Before installing the oxygen sensor, apply anti-seize compound only to the threaded portion of oxygen sensor to make the next removal easier.

**Anti-seize compound:**  
**SS-30 by JET LUBE**

### CAUTION:

Never apply anti-seize compound to the protector of oxygen sensor.

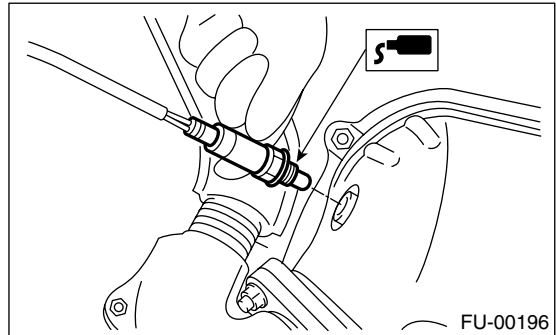

- 2) Install the oxygen sensor.

### Tightening torque:

**21 N·m (2.1 kgf·m, 15.2 ft·lb)**

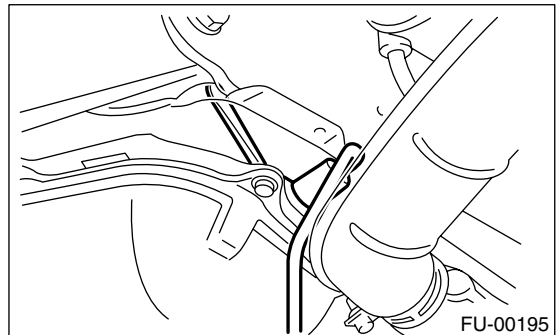

- 3) Lower the vehicle.
- 4) Connect the connector of oxygen sensor.

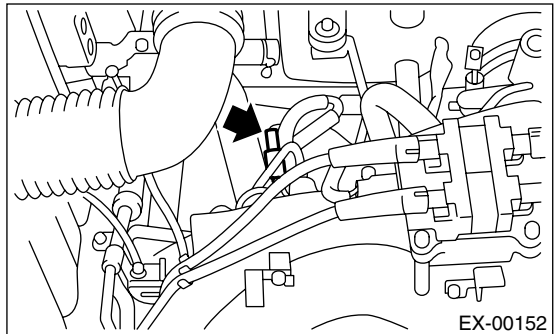

# Oxygen Sensor

FUEL INJECTION (FUEL SYSTEMS)

---

5) Connect the battery ground cable to battery.

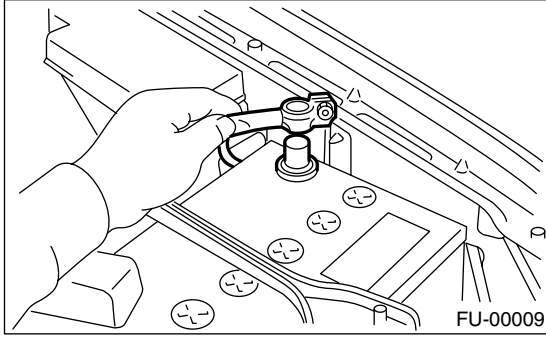

## 13.Engine Control Module (ECM)

### A: REMOVAL

1) Disconnect the ground cable from battery.

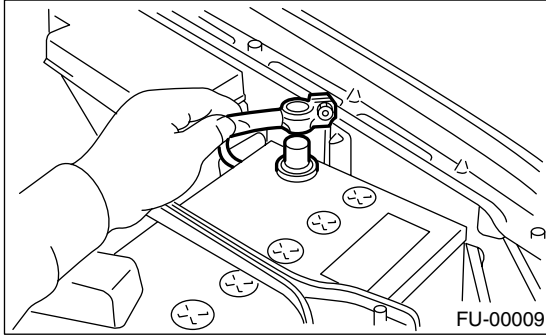

2) Remove the lower inner trim of passenger side.

<Ref. to EI-47, REMOVAL, Lower Inner Trim.>

3) Detach the floor mat of front passenger seat.

4) Remove the protect cover.

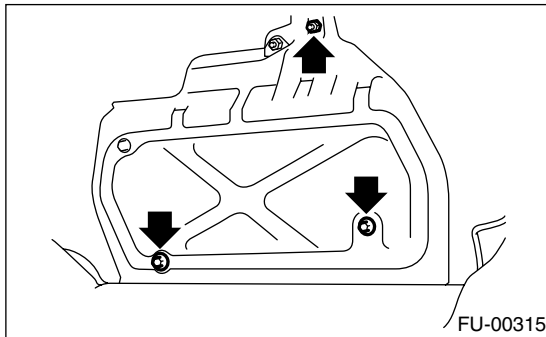

5) Remove the nuts (A) which hold the ECM to bracket.

6) Remove the clip (B) from bracket.

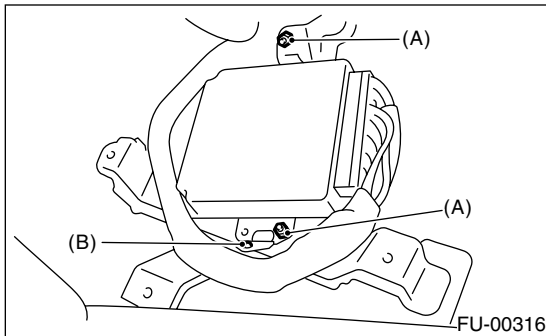

7) Disconnect the ECM connectors and take out the ECM.

### B: INSTALLATION

Install in the reverse order of removal.

#### CAUTION:

When replacing the ECM, be careful not to use the wrong spec. ECM to avoid any damage to fuel injection system.

*Tightening torque:*

*5 N·m (0.51 kgf-m, 3.7 ft-lb)*

## 14.Main Relay

### A: REMOVAL

- 1) Disconnect the ground cable from battery.

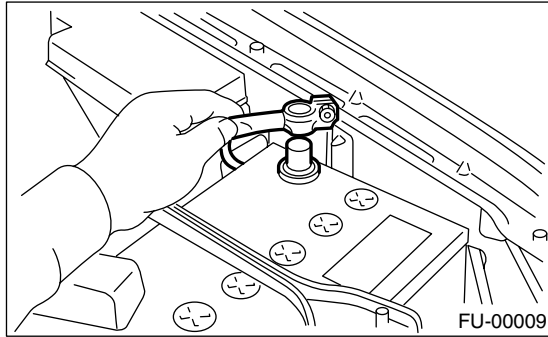

- 2) Remove the front side sill cover of passenger side.
- 3) Remove the bolt which holds the main relay bracket on body.
- 4) Disconnect the connectors from main relay.

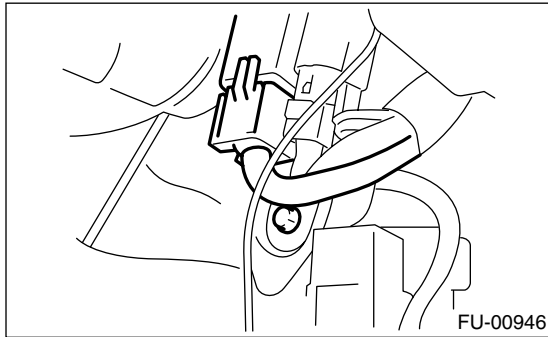

### B: INSTALLATION

Install in the reverse order of removal.

## 15. Fuel Pump Relay

### A: REMOVAL

1) Disconnect the ground cable from battery.

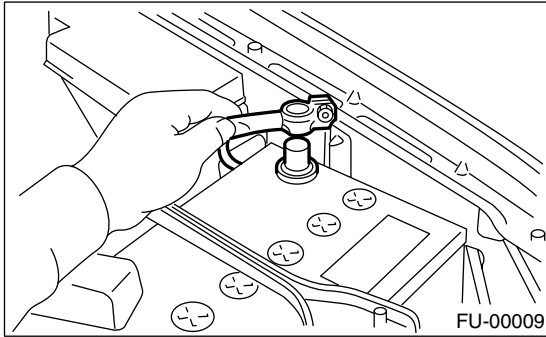

2) Remove the front side sill cover of passenger side.

3) Remove the bolt which holds the fuel pump relay bracket on body.

4) Disconnect the connector from fuel pump relay.

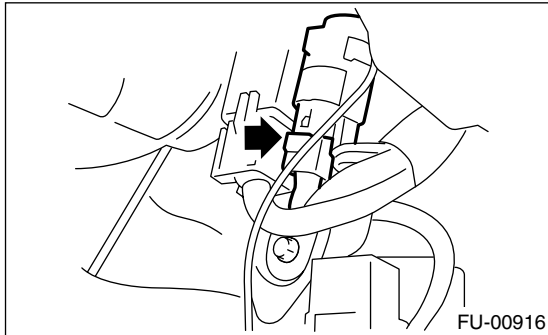

5) Remove the fuel pump relay from mounting bracket.

### B: INSTALLATION

Install in the reverse order of removal.

### 16. Fuel

#### A: OPERATION

##### 1. RELEASING OF FUEL PRESSURE

###### WARNING:

- Place “NO FIRE” signs near working area.
- Be careful not to spill fuel on floor.

1) Disconnect the connector from fuel pump relay.

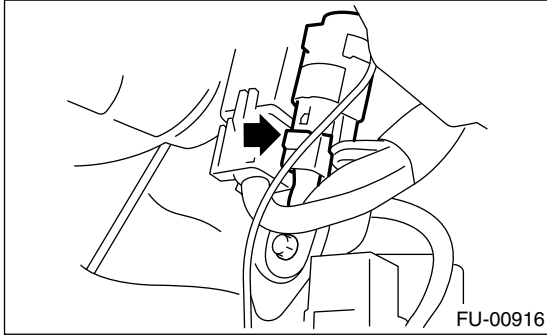

- 2) Start and run the engine until it stalls.
- 3) After the engine stalls, crank it for 5 more seconds.
- 4) Turn the ignition switch to OFF.

##### 2. DRAINING FUEL

###### WARNING:

- Place “NO FIRE” signs near working area.
- Be careful not to spill fuel on floor.

- 1) Set the vehicle on a lift.
- 2) Disconnect the ground cable from battery.

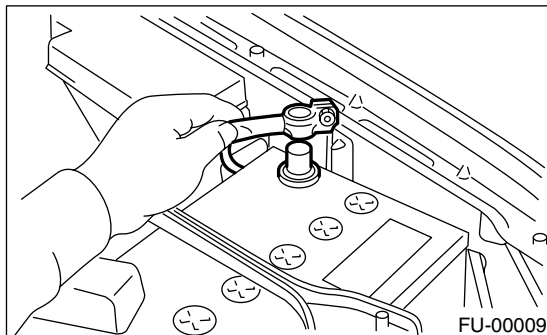

- 3) Open the fuel filler flap lid and remove the fuel filler cap.
- 4) Lift-up the vehicle.

5) Drain fuel from fuel tank.

Set a container under the vehicle and remove the drain plug from fuel tank.

- 1.6 L and 2.0 L MODEL

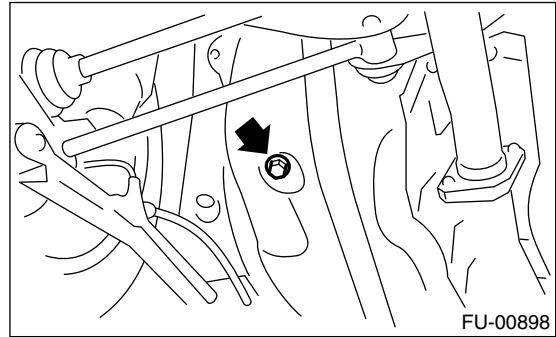

- 2.5 L MODEL

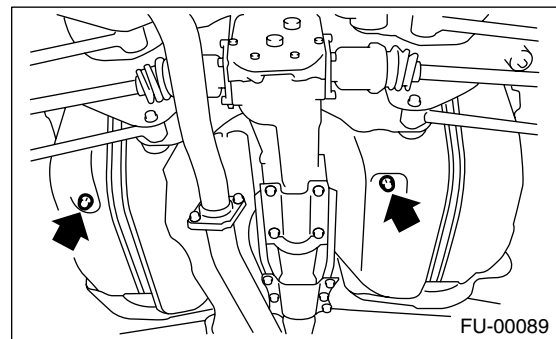

6) Tighten the fuel drain plug.

###### Tightening torque:

**26 N·m (2.7 kgf-m, 19.2 ft-lb)**

## 17. Fuel Tank

### A: REMOVAL

**WARNING:**

- Place “NO FIRE” signs near working area.
- Be careful not to spill fuel on floor.

- 1) Set the vehicle on a lift.
- 2) Release the fuel pressure. <Ref. to FU(H4S0w/oOBD)-46, RELEASING OF FUEL PRESSURE, OPERATION, Fuel.>
- 3) Drain fuel from fuel tank. <Ref. to FU(H4S0w/oOBD)-46, DRAINING FUEL, OPERATION, Fuel.>
- 4) Remove the rear seat.
- 5) Disconnect the connector (A) of fuel tank cord to rear harness.
- 6) Push the grommet (B) which hold the fuel tank cord on floor panel down under body.

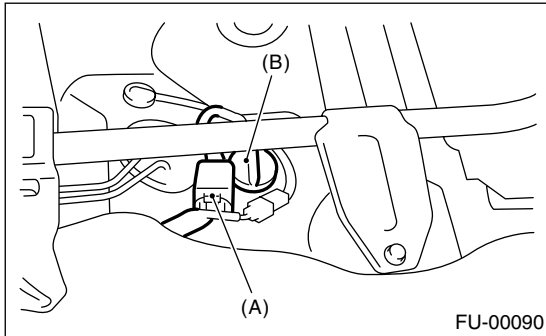

- 7) Remove the rear crossmember. <Ref. to RS-21, REMOVAL, Rear Crossmember.>
- 8) Disconnect the two-way valve hose (A) from two-way valve and disconnect the canister hose (B) from canister.

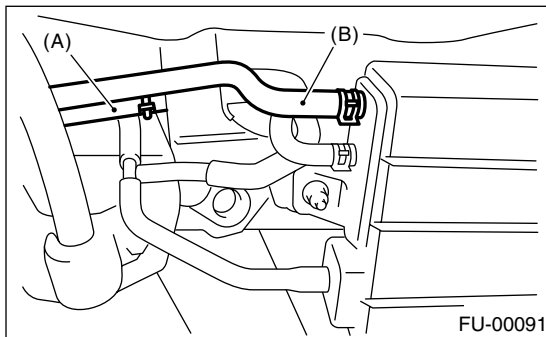

- 9) Loosen the clamp and disconnect the fuel filler hose and air vent hose from fuel filler pipe.

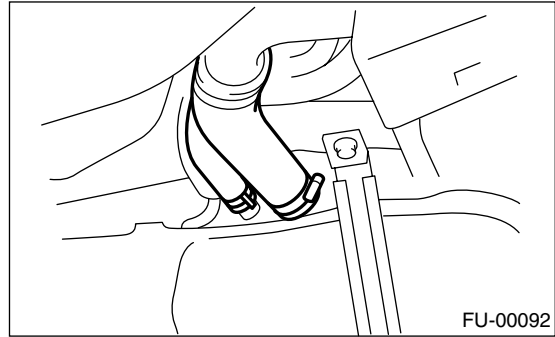

- 10) Move the clips, and then disconnect the quick connector. <Ref. to FU(H4S0w/oOBD)-62, REMOVAL, Fuel Delivery, Return and Evaporation Lines.>
- 11) Disconnect the fuel hoses.

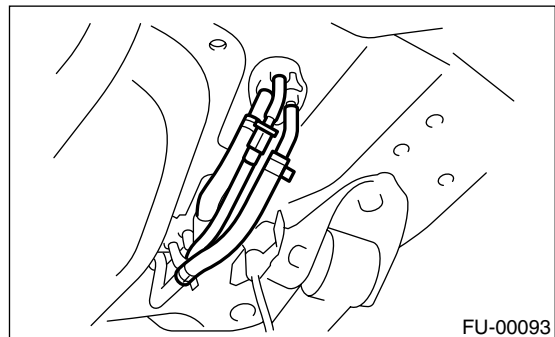

- 12) Support the fuel tank with transmission jack, remove the bolts from bands, and then dismantle the fuel tank from vehicle.

**WARNING:**

**A helper is required to perform this work.**

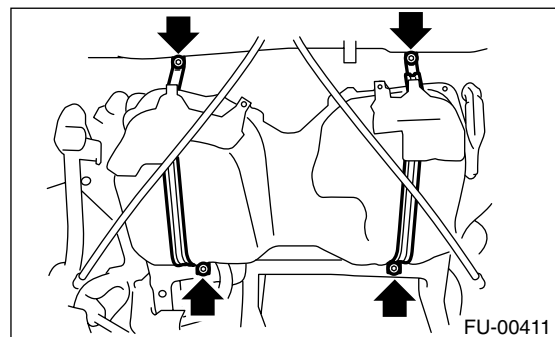

# Fuel Tank

## FUEL INJECTION (FUEL SYSTEMS)

### B: INSTALLATION

1) Support the fuel tank with transmission jack and push the fuel tank harness into access hole with grommet.

2) Set the fuel tank and temporarily tighten the bolts of fuel tank bands.

#### WARNING:

**A helper is required to perform this work.**

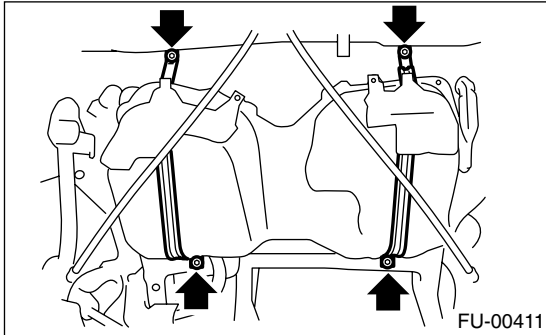

3) Connect the two-way valve hose (A) to two-way valve and connect the canister hose (B) to canister.

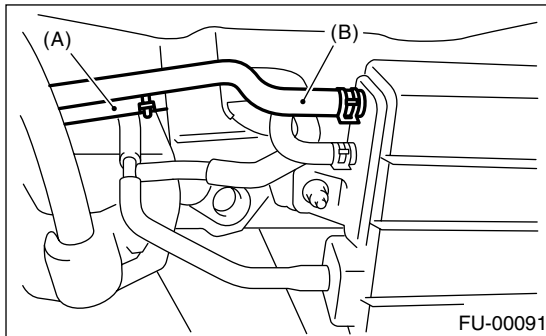

4) Connect the fuel filler hose and air vent hose.

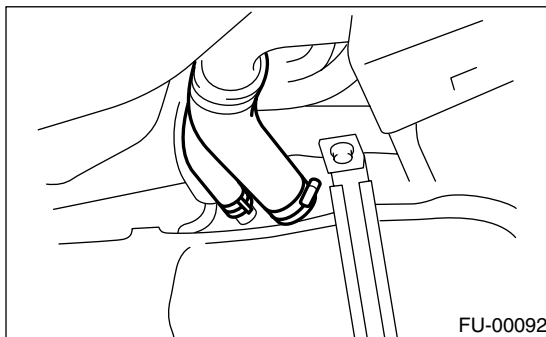

5) Connect the fuel hoses, and then secure them with clips and quick connector. <Ref. to FU(H4SOw/oOBD)-63, INSTALLATION, Fuel Delivery, Return and Evaporation Lines.>

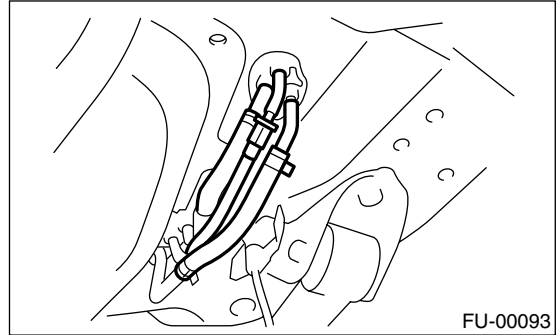

6) Tighten the band mounting bolts.

#### Tightening torque:

**33 N·m (3.4 kgf·m, 24.3 ft·lb)**

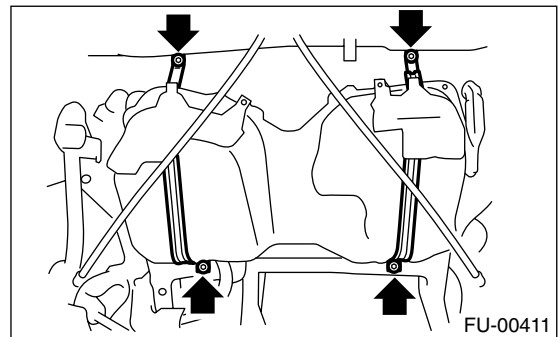

7) Install the rear crossmember. <Ref. to RS-21, INSTALLATION, Rear Crossmember.>

8) Connect the connectors (A) to fuel tank cord and plug the service hole with grommet (B).

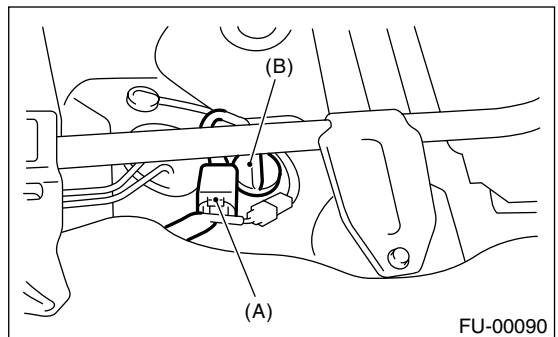

9) Set the rear seat and floor mat.



10) Connect the connector to the fuel pump relay.

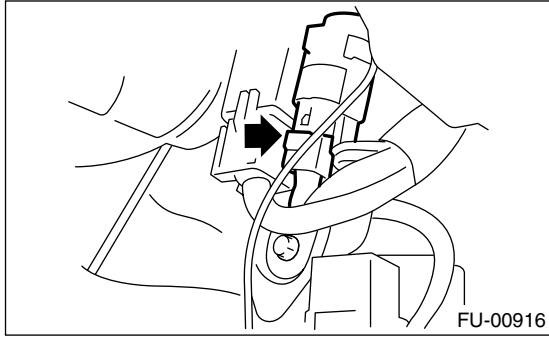

### **C: INSPECTION**

- 1) Make sure there are no cracks, holes or other damage on fuel tank.
- 2) Make sure the fuel hoses and fuel pipes are not cracked and the connections are tightened firmly.

# Fuel Filler Pipe

FUEL INJECTION (FUEL SYSTEMS)

## 18. Fuel Filler Pipe

### A: REMOVAL

#### WARNING:

- Place “NO FIRE” signs near working area.
- Be careful not to spill fuel on floor.

- 1) Set the vehicle on a lift.
- 2) Release the fuel pressure. <Ref. to FU(H4SOw/oOBD)-46, RELEASING OF FUEL PRESSURE, OPERATION, Fuel.>
- 3) Open the fuel filler flap lid and remove the fuel filler cap.
- 4) Disconnect the ground cable from battery.

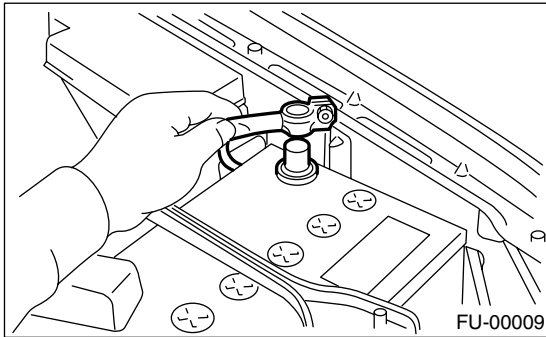

- 5) Remove the screws holding packing in place.

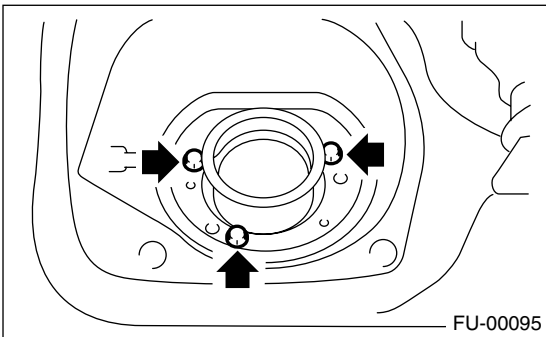

- 6) Remove the nuts of rear wheel RH.
- 7) Lift-up the vehicle.
- 8) Remove the rear wheel RH.

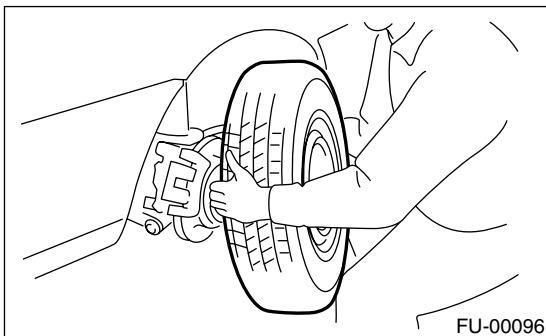

- 9) Drain fuel from the fuel tank. Set a container under the vehicle and remove the drain plug from fuel tank.

- 1.6 L and 2.0 L MODEL

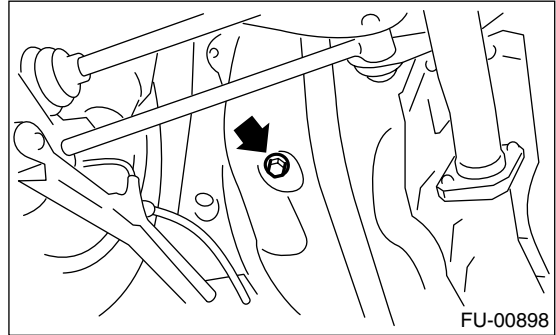

- 2.5 L MODEL

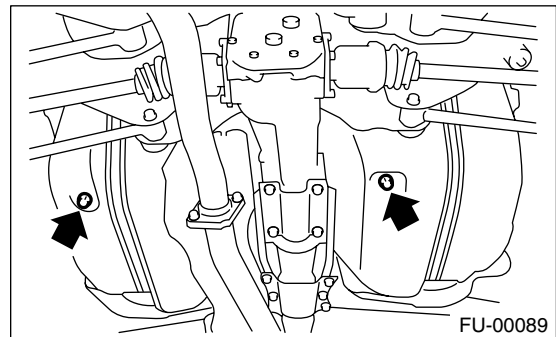

- 10) Tighten the fuel drain plug and then install the front right side tank cover.

#### Tightening torque:

**26 N·m (2.7 kgf-m, 19.2 ft-lb)**

- 11) Remove the fuel filler pipe protector.

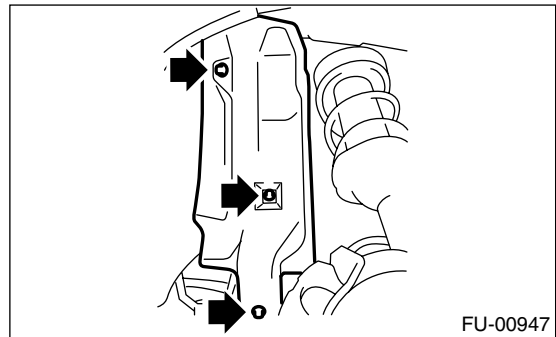

# Fuel Filler Pipe

FUEL INJECTION (FUEL SYSTEMS)

12) Separate the evaporation hoses from clip of fuel filler pipe.

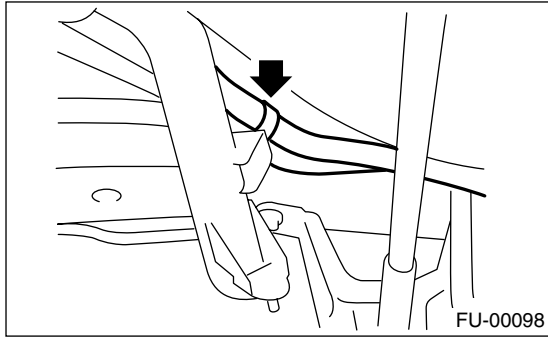

13) Disconnect the air vent hose from fuel filler pipe.

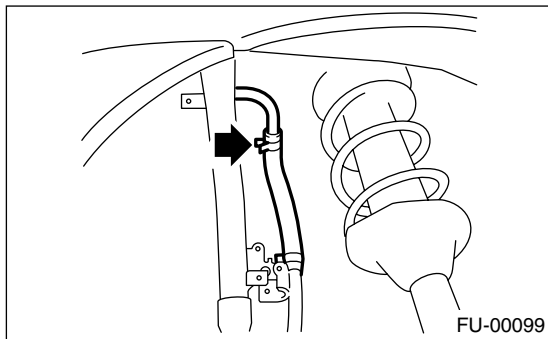

14) Remove the bolt which holds the fuel filler pipe bracket on body.

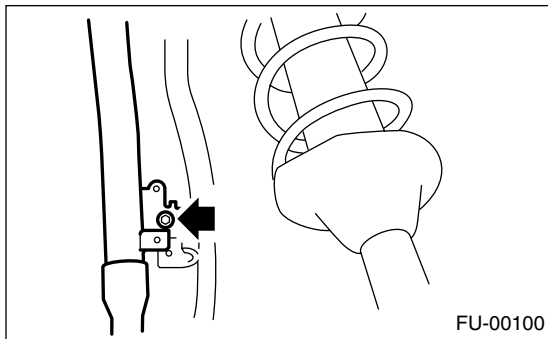

15) Loosen the clamp and separate the fuel filler hose (A) from fuel filler pipe.

16) Move the clip and separate the air vent hose (B).

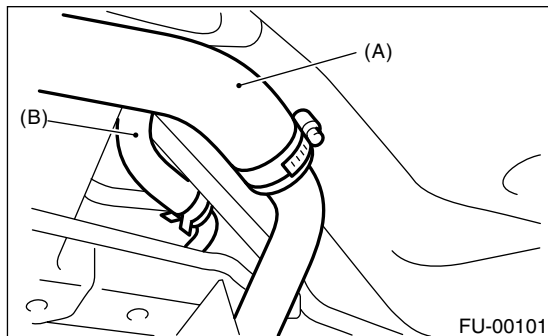

17) Remove the fuel filler pipe to under side of vehicle.

18) Remove the air vent pipe together with clip from body.

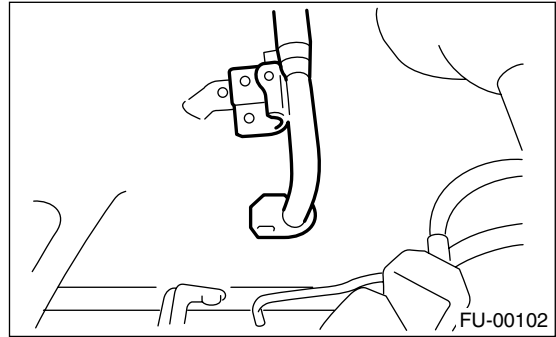

## B: INSTALLATION

1) Open the fuel filler flap lid.

2) Set the fuel saucer (A) with rubber packing (C) and insert the fuel filler pipe into hole from the inner side of apron.

3) Align the holes in fuel filler pipe neck, set the cup (B), and then tighten the screws.

### NOTE:

If the edges of rubber packing are folded toward inside, straighten it with a screwdriver.

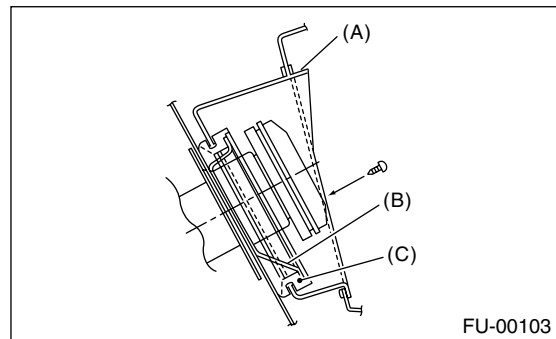

4) Install the air vent pipe.

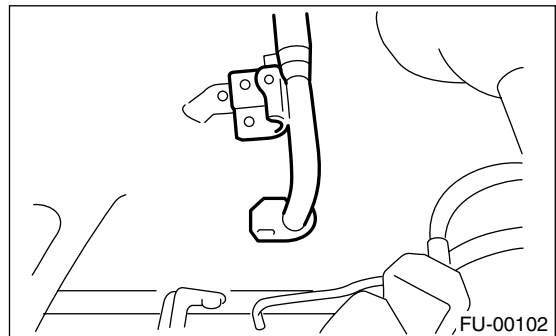

# Fuel Filler Pipe

## FUEL INJECTION (FUEL SYSTEMS)

5) Connect the air vent hose to the fuel filler pipe.

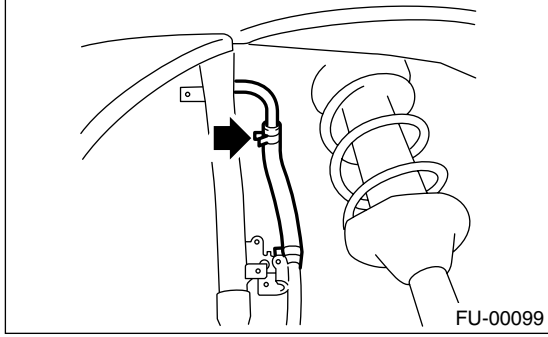

6) Insert the fuel filler hose (A) approx. 35 to 40 mm (1.38 to 1.57 in) over the lower end of fuel filler pipe and tighten the clamp.

### CAUTION:

Do not allow the clips to touch the air vent hose (B) and rear suspension crossmember.

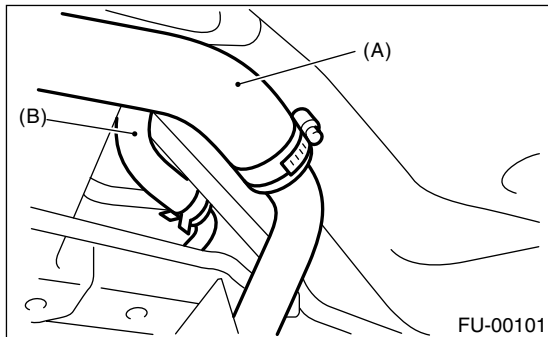

7) Insert the air vent hose approx. 25 to 30 mm (0.98 to 1.18 in) into the lower end of air vent pipe and hold clip.

$L = 27.5 \pm 2.5 \text{ mm (1.083} \pm 0.098 \text{ in)}$

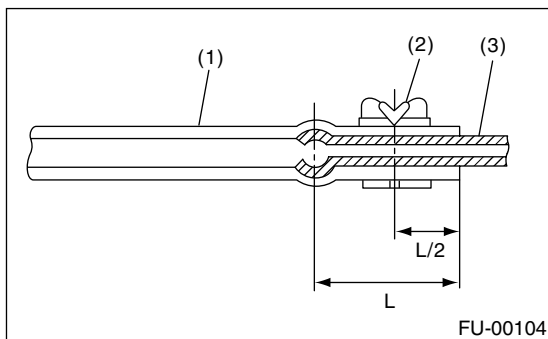

- (1) Hose
- (2) Clip
- (3) Pipe

8) Tighten the bolt which holds the fuel filler pipe bracket on body.

### Tightening torque:

$7.4 \text{ N}\cdot\text{m (0.75 kgf}\cdot\text{m, 5.4 ft}\cdot\text{lb)}$

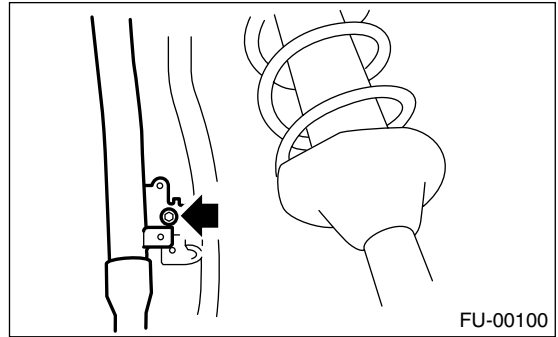

9) Tighten the bolts which hold the evaporation hoses onto clip of fuel filler pipe.

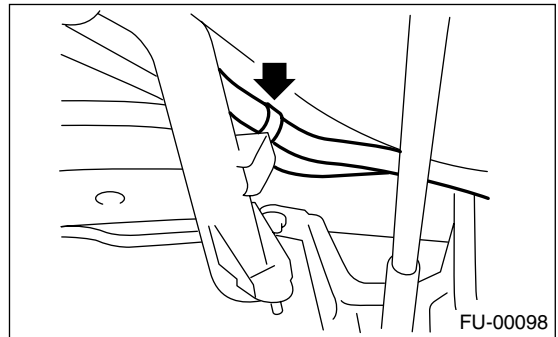

10) Install the fuel filler pipe protector.

### Tightening torque:

$7.4 \text{ N}\cdot\text{m (0.75 kgf}\cdot\text{m, 5.4 ft}\cdot\text{lb)}$

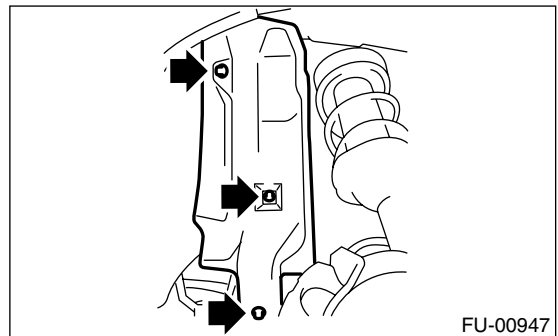

11) Install the rear wheel RH.

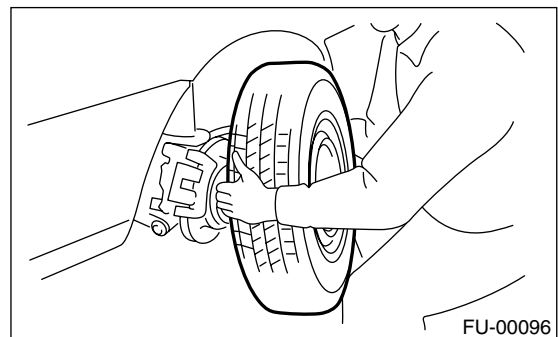

- 12) Lower the vehicle.
- 13) Tighten the wheel nuts.
- 14) Connect the connector to the fuel pump relay.

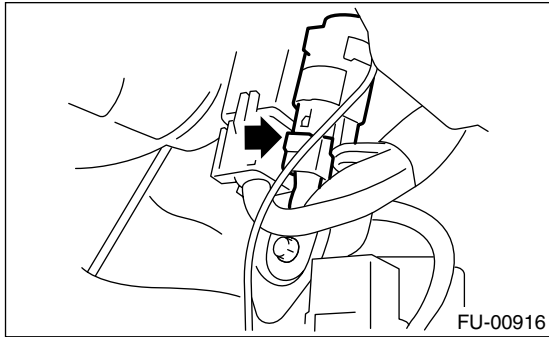

- 15) Connect the battery ground cable to battery.

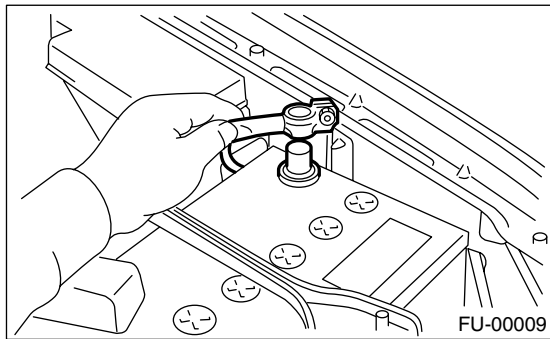

# Fuel Pump

FUEL INJECTION (FUEL SYSTEMS)

## 19. Fuel Pump

### A: REMOVAL

#### WARNING:

- Place “NO FIRE” signs near working area.
- Be careful not to spill fuel on floor.

#### NOTE:

Fuel pump assembly consists of fuel pump and fuel level sensor.

#### • 1.6 L and 2.0 L MODEL

1) Release the fuel pressure. <Ref. to FU(H4S0w/oOBD)-46, RELEASING OF FUEL PRESSURE, OPERATION, Fuel.>

2) Open the fuel filler flap lid and remove the fuel filler cap.

3) Disconnect the ground cable from battery.

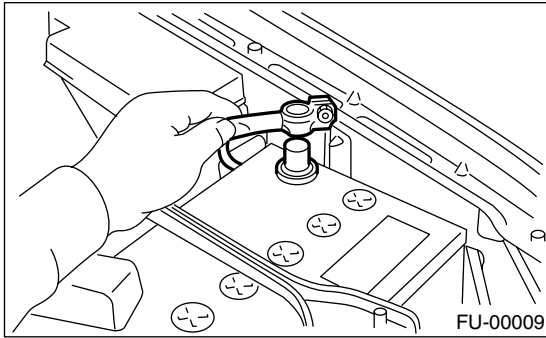

4) Lift-up the vehicle.

5) Drain fuel from fuel tank. Set a container under vehicle and remove the drain plug from fuel tank.

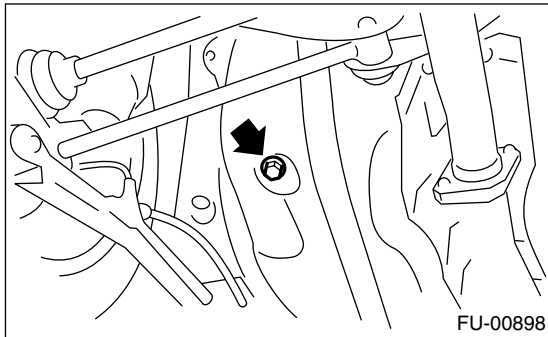

6) Tighten the fuel drain plug.

#### Tightening torque:

**26 N·m (2.7 kgf·m, 19.2 ft·lb)**

7) Raise the rear seat and turn the floor mat up.

8) Remove the access hole lid.

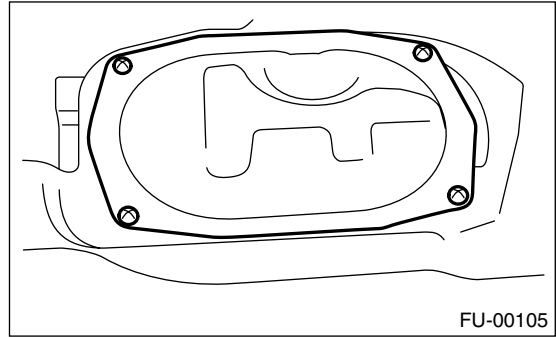

9) Disconnect the connector from fuel pump.

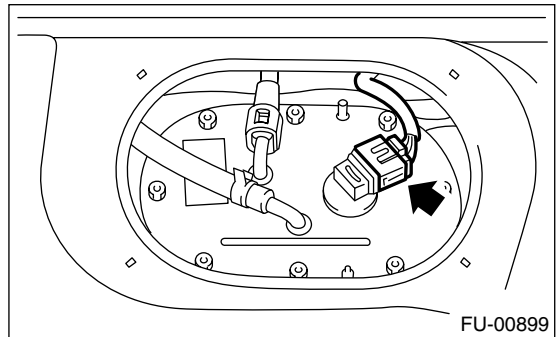

10) Disconnect the quick connector and then disconnect the fuel delivery hose (A). <Ref. to FU(H4S0w/oOBD)-62, REMOVAL, Fuel Delivery, Return and Evaporation Lines.>

11) Move the clip and then disconnect the fuel return hose (B).

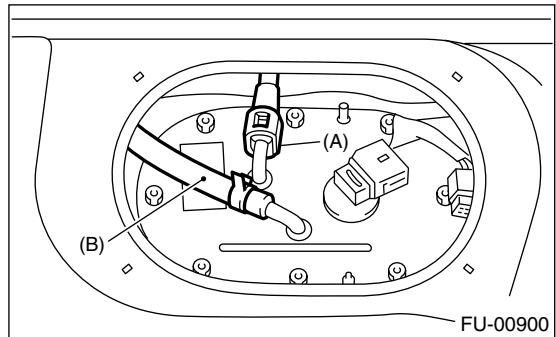

12) Remove the nuts which install the fuel pump assembly onto fuel tank.

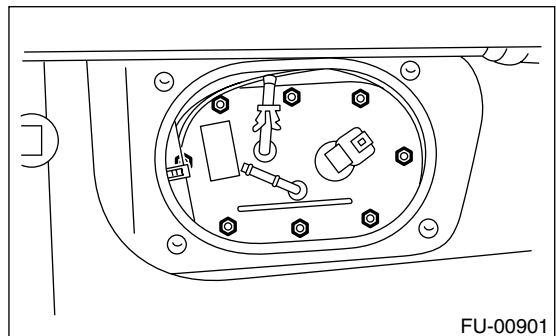

13) Take off the fuel pump assembly from fuel tank.

# Fuel Pump

FUEL INJECTION (FUEL SYSTEMS)

## • 2.5 L MODEL

- 1) Release the fuel pressure. <Ref. to FU(H4SOw/oOBD)-46, RELEASING OF FUEL PRESSURE, OPERATION, Fuel.>
- 2) Open the fuel filler flap lid and remove the fuel filler cap.
- 3) Disconnect the ground cable from battery.

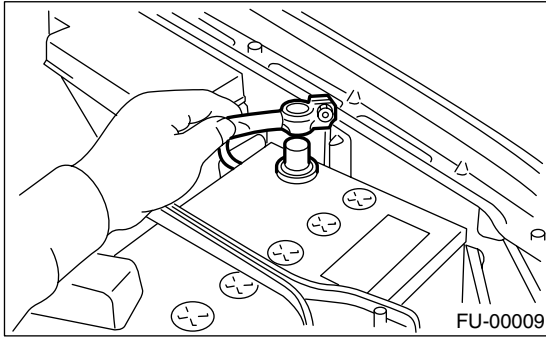

- 4) Lift-up the vehicle.
- 5) Drain fuel from fuel tank. Set a container under the vehicle and remove the drain plug from fuel tank.

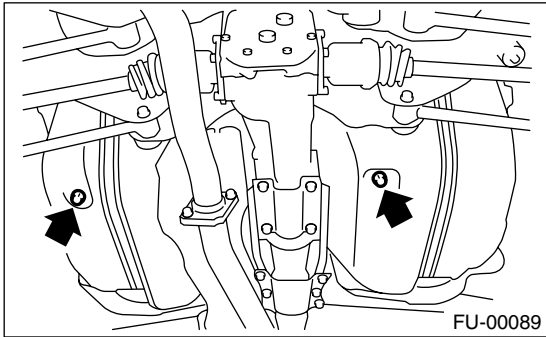

- 6) Tighten the fuel drain plug.

### **Tightening torque:**

**26 N·m (2.7 kgf·m, 19.2 ft·lb)**

- 7) Raise the rear seat and turn the floor mat up.
- 8) Remove the access hole lid.

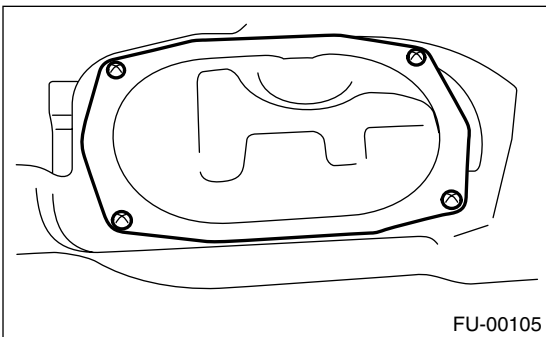

- 9) Disconnect the connector from fuel pump.

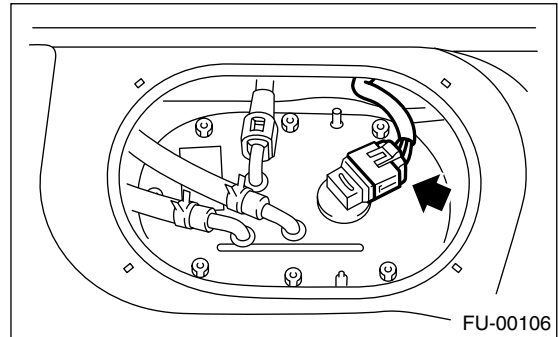

- 10) Disconnect the quick connector, and then disconnect the fuel delivery hose (A). <Ref. to FU(H4SOw/oOBD)-62, REMOVAL, Fuel Delivery, Return and Evaporation Lines.>
- 11) Move the clips, and then disconnect the fuel return hose (B) and jet pump hose (C).

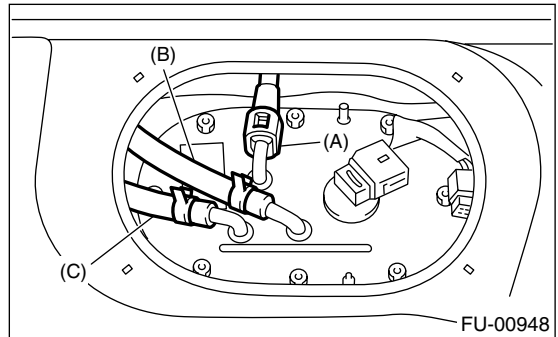

- 12) Remove the nuts which install the fuel pump assembly onto fuel tank.

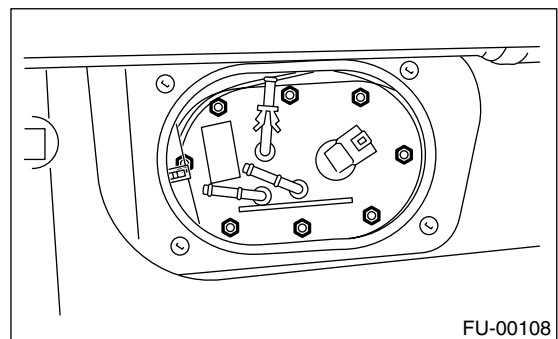

- 13) Take off the fuel pump assembly from fuel tank.

# Fuel Pump

## FUEL INJECTION (FUEL SYSTEMS)

### B: INSTALLATION

Install in the reverse order of removal. Do the following:

NOTE:

Always use new gaskets.

- (1) Ensure the sealing portion is free from fuel or foreign particles before installation.
- (2) Tighten the nuts to specified torque in alphabetical sequence shown in the figure.

**Tightening torque:**

**4.4 N·m (0.45 kgf-m, 3.3 ft-lb)**

- 1.6 L and 2.0 L MODEL

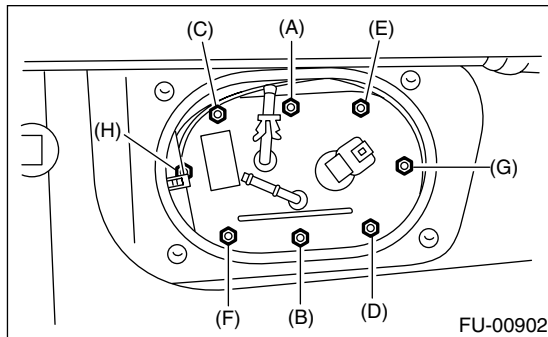

- 2.5 L MODEL

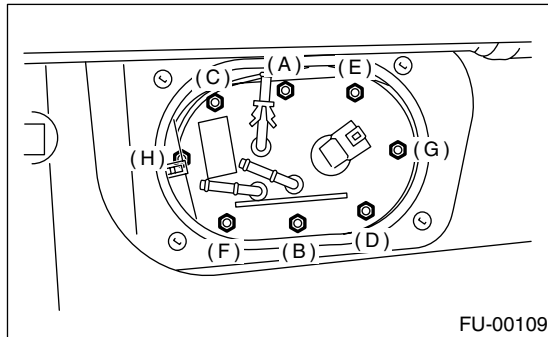

### C: INSPECTION

Connect the lead harness to connector terminal of fuel pump and apply battery power supply to check whether the pump operates.

**WARNING:**

- **Wipe off the fuel completely.**
- **Keep the battery as far apart from fuel pump as possible.**
- **Be sure to turn the battery supply ON and OFF on battery side.**
- **Do not run the fuel pump for a long time under non-load condition.**

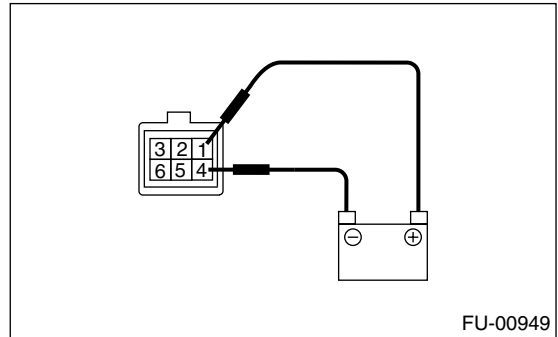



## 20. Fuel Level Sensor

### A: REMOVAL

#### WARNING:

- Place “NO FIRE” signs near working area.
- Be careful not to spill fuel on floor.

#### NOTE:

Fuel level sensor is built in the fuel pump assembly.

1) Remove the fuel pump assembly. <Ref. to FU(H4SOw/oOBD)-54, REMOVAL, Fuel Pump.>

2) Disconnect the connector from fuel pump bracket.

- 1.6 L and 2.0 L MODEL

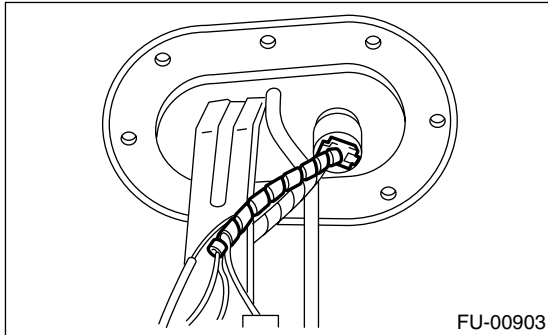

- 2.5 L MODEL

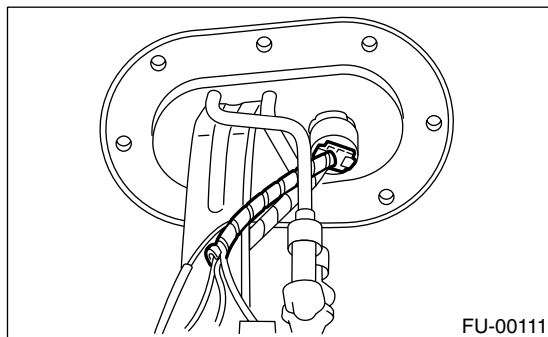

3) Remove the bolt which installs the fuel level sensor on mounting bracket.

- 1.6 L and 2.0 L MODEL

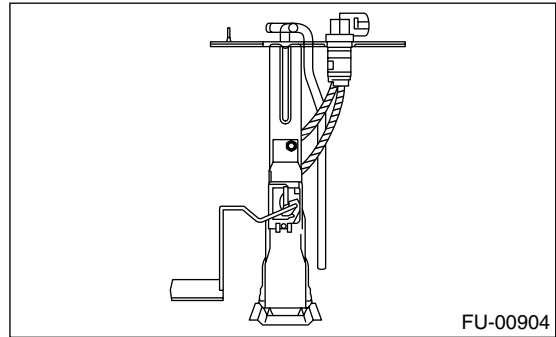

- 2.5 L MODEL

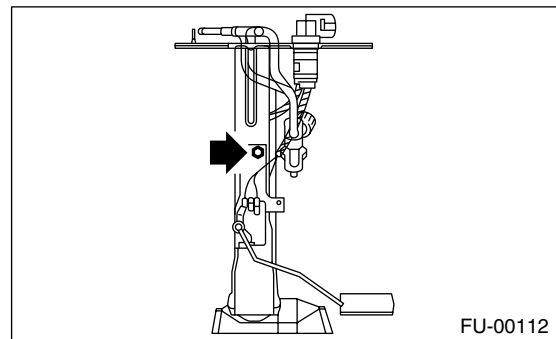

### B: INSTALLATION

Install in the reverse order of removal.

# Fuel Sub Level Sensor

FUEL INJECTION (FUEL SYSTEMS)

## 21. Fuel Sub Level Sensor

### A: REMOVAL

NOTE:

Fuel sub level sensor is equipped to only 2.5 L model.

**WARNING:**

- Place “NO FIRE” signs near working area.
- Be careful not to spill fuel on floor.

1) Disconnect the ground cable from battery.

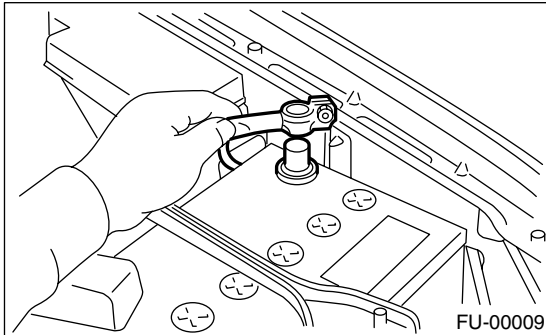

2) Lift-up the vehicle.

3) Drain fuel from fuel tank. Set a container under vehicle and remove the drain plug from fuel tank.

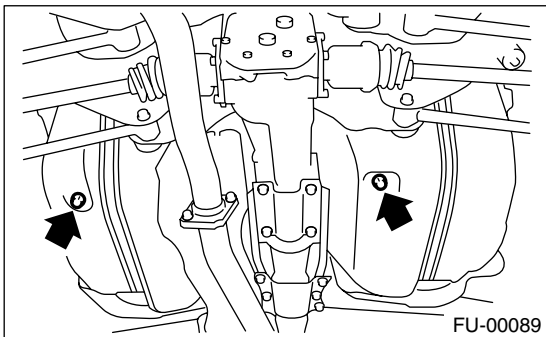

4) Tighten the fuel drain plug.

**Tightening torque:**

**26 N·m (2.7 kgf·m, 19.2 ft·lb)**

5) Remove the rear seat.

6) Remove the service hole cover.

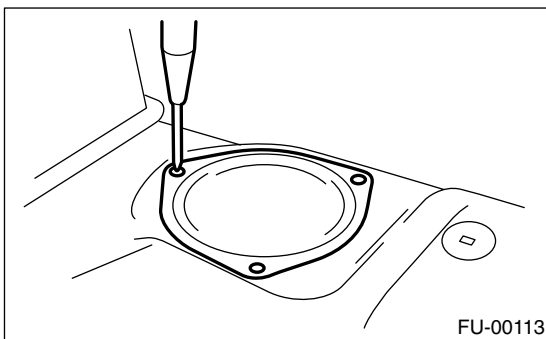

7) Disconnect the connector from fuel sub level sensor.

8) Disconnect the fuel jet pump hose.

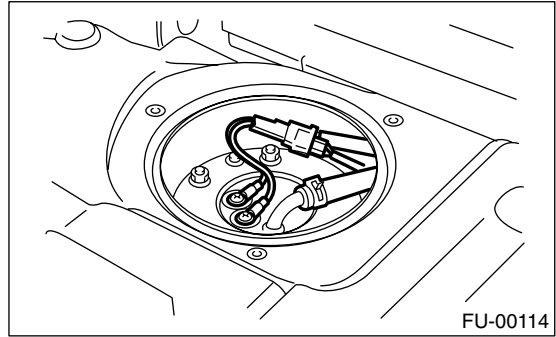

9) Remove the bolts which install the fuel sub meter unit on fuel tank.

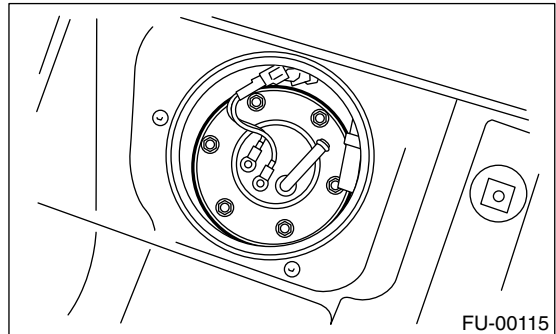

10) Remove the fuel sub level sensor.

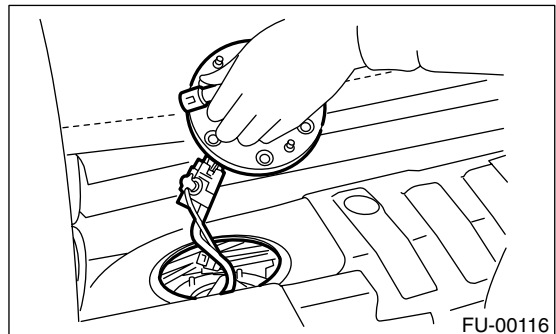

### B: INSTALLATION

Install in the reverse order of removal.

**Tightening torque:**

**4.4 N·m (0.45 kgf·m, 3.3 ft·lb)**

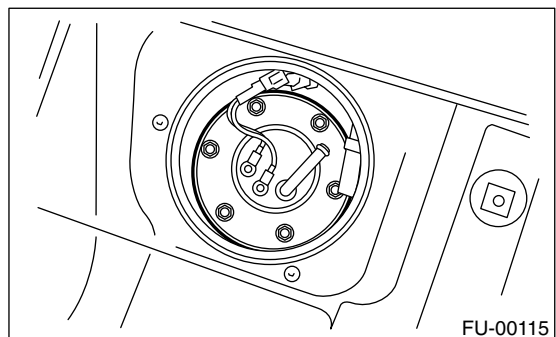

## 22. Fuel Filter

### A: REMOVAL

**WARNING:**

- Place “NO FIRE” signs near working area.
- Be careful not to spill fuel on floor.

- 1) Release the fuel pressure. <Ref. to FU(H4SOw/oOBD)-46, RELEASING OF FUEL PRESSURE, OPERATION, Fuel.>
- 2) Disconnect the fuel delivery hoses from fuel filter.

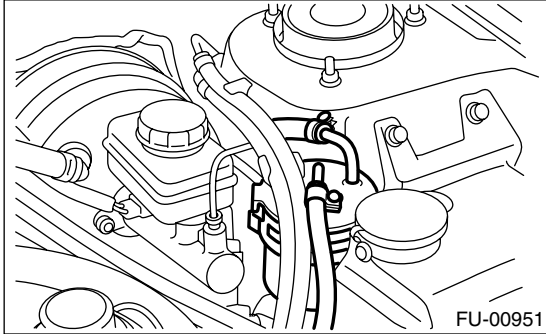

- 3) Remove the filter from holder.

### B: INSTALLATION

**CAUTION:**

- If fuel hoses are damaged at connecting portion, replace them with new ones.
- If clamps are badly damaged, replace them with new ones.

- 1) Install in the reverse order of removal.
- 2) Tighten the hose clamp screws.

**Tightening torque:**

**1.25 N·m (0.13 kgf·m, 0.94 ft·lb)**

### C: INSPECTION

- 1) Check the inside of fuel filter for dirt and water sediment.
- 2) If it is clogged, or if replacement interval has been reached, replace it.
- 3) If water is found in it, shake and expel the water from inlet port.

## 23. Fuel Cut Valve

### A: REMOVAL

**WARNING:**

- Place “NO FIRE” signs near working area.
- Be careful not to spill fuel on floor.

- 1) Remove the fuel tank. <Ref. to FU(H4SOw/oOBD)-47, REMOVAL, Fuel Tank.>
- 2) Move the clip and disconnect the evaporation hose from fuel cut valve.

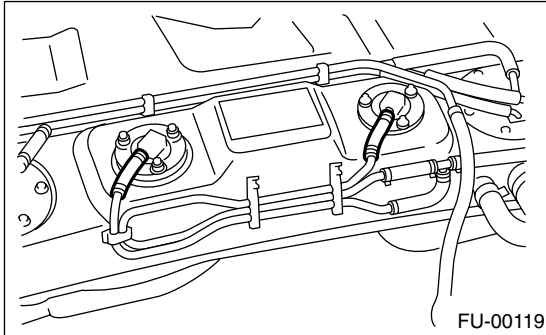

- 3) Remove the bolts which install the fuel cut valve.

### B: INSTALLATION

Install in the reverse order of removal.

**NOTE:**

For tightening torque, refer to “COMPONENT”.  
<Ref. to FU(H4SOw/oOBD)-3, COMPONENT, General Description.>

## 24. Fuel Damper Valve

### A: REMOVAL

1) Release the fuel pressure. <Ref. to FU(H4SOw/oOBD)-46, RELEASING OF FUEL PRESSURE, OPERATION, Fuel.>

2) Remove the fuel damper valve from fuel return line.

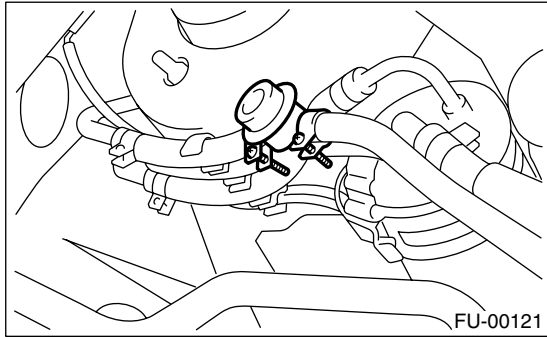

### B: INSTALLATION

Install in the reverse order of removal.

# Fuel Delivery, Return and Evaporation Lines

FUEL INJECTION (FUEL SYSTEMS)

## 25. Fuel Delivery, Return and Evaporation Lines

### A: REMOVAL

- 1) Set the vehicle on a lift.
- 2) Release the fuel pressure. <Ref. to FU(H4SOw/oOBD)-46, RELEASING OF FUEL PRESSURE, OPERATION, Fuel.>
- 3) Open the fuel filler flap lid and remove the fuel filler cap.
- 4) Remove the floor mat. <Ref. to EI-55, REMOVAL, Floor Mat.>
- 5) Remove the fuel delivery pipes and hoses, fuel return pipes and hoses, evaporation pipes and hoses.

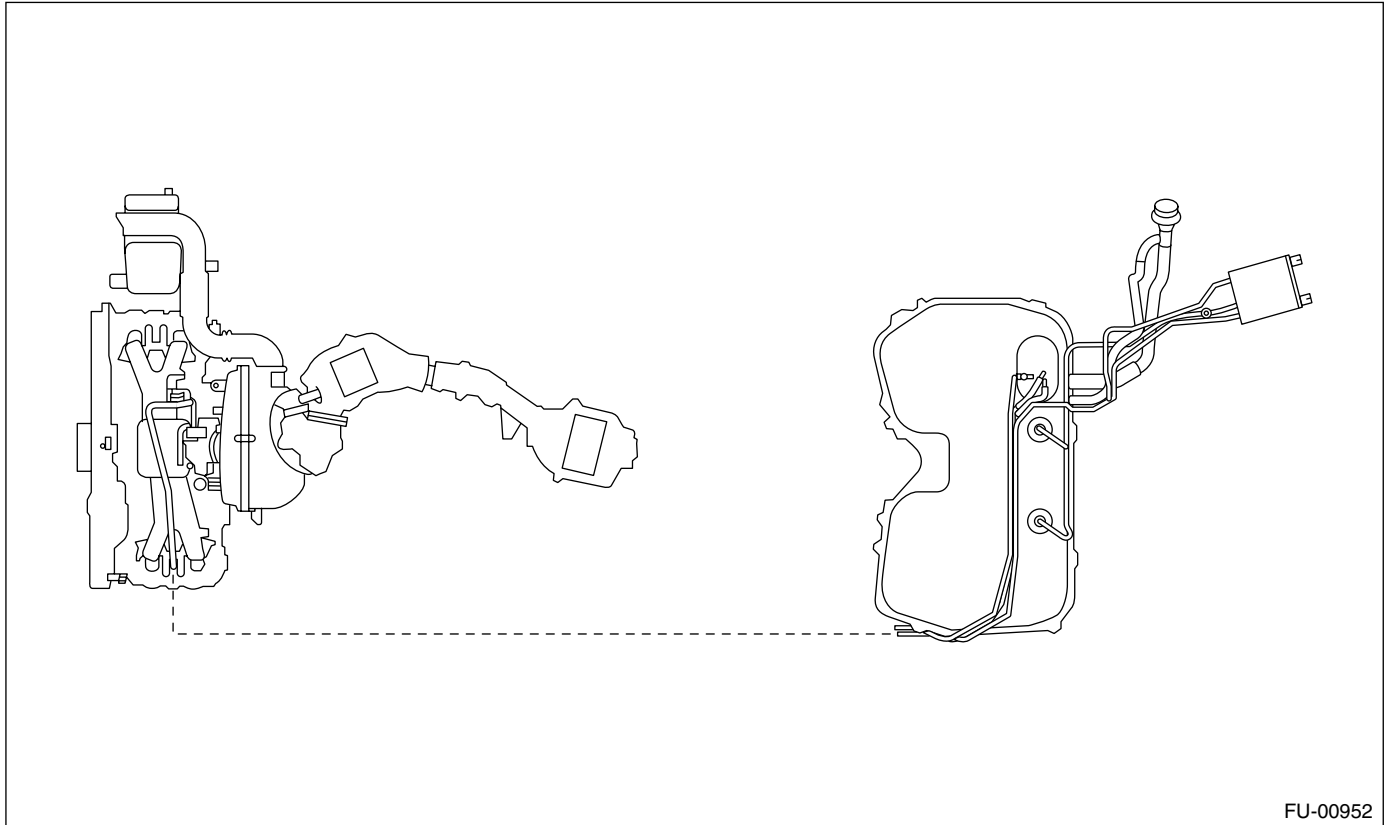

FU-00952

6) In the engine compartment, detach the fuel delivery hoses, return hoses and evaporation hose.

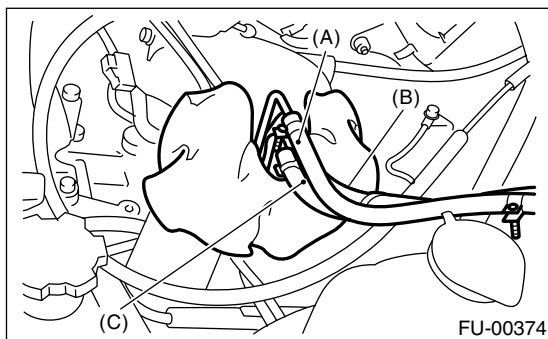

FU-00374

- (A) Fuel delivery hose
- (B) Return hose
- (C) Evaporation hose

8) Disconnect the two-way valve hose (A) from two-way valve and disconnect the canister hose (B) from canister.

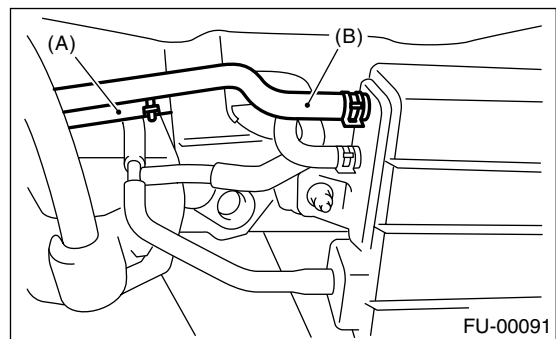

FU-00091

7) Lift-up the vehicle.

# Fuel Delivery, Return and Evaporation Lines

FUEL INJECTION (FUEL SYSTEMS)

9) Separate the quick connector on fuel delivery line.

- (1) Clean the pipe and connector, if they are covered with dust.
- (2) Hold the connector (A) and push retainer (B) down.
- (3) Pull out the connector (A) from retainer (B).

NOTE:

Replace the retainer with a new one.

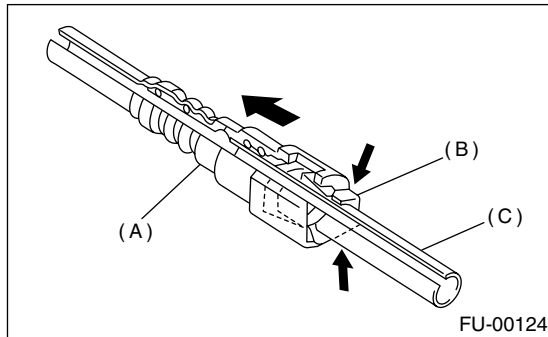

- (A) Connector
- (B) Retainer
- (C) Pipe

## B: INSTALLATION

1) Connect the quick connector on fuel delivery line.

NOTE:

- Always use a new retainer.
- Make sure the connected portion is not damaged or not covered with dust. If necessary, clean the seal surface of pipe.

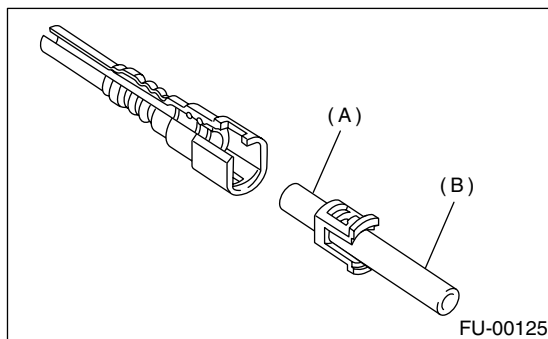

- (A) Seal surface
- (B) Pipe

- (1) Set the new retainer (B) to connector (A).
- (2) Push the pipe into connector completely.

NOTE:

At this time, two clicking sounds are heard.

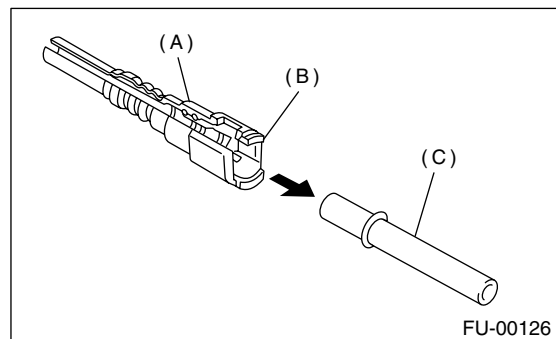

- (A) Connector
- (B) Retainer
- (C) Pipe

CAUTION:

- Pull the connector to ensure it is connected securely.
- Ensure the two retainer pawls are engaged in their mating positions in connector.
- Be sure to inspect the hoses and their connections for any leakage of fuel.

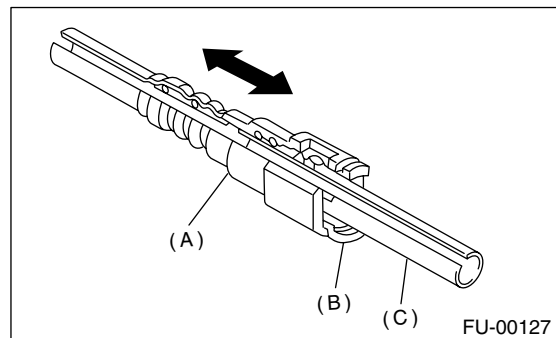

- (A) Connector
- (B) Retainer
- (C) Pipe

# Fuel Delivery, Return and Evaporation Lines

## FUEL INJECTION (FUEL SYSTEMS)

2) Connect the fuel delivery hose to pipe with an overlap of 20 to 25 mm (0.79 to 0.98 in).

Type A: When the fitting length is specified.

Type B: When the fitting length is not specified.

$\varnothing : 2.5 \pm 1.5 \text{ mm } (0.098 \pm 0.059 \text{ in})$

$L : 22.5 \pm 2.5 \text{ mm } (0.886 \pm 0.098 \text{ in})$

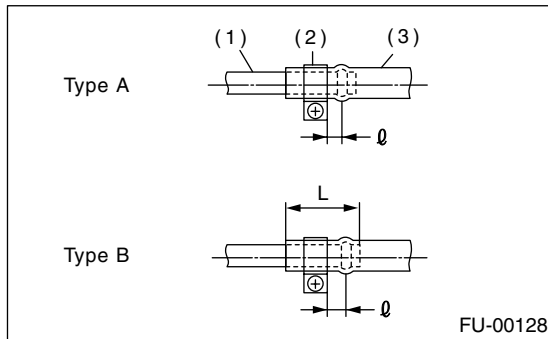

- (1) Fitting
- (2) Clamp
- (3) Hose

3) Connect the evaporation hose to pipe by approx. 15 mm (0.59 in) from hose end.

$L = 17.5 \pm 2.5 \text{ mm } (0.689 \pm 0.098 \text{ in})$

### CAUTION:

**Be sure to inspect the hoses and their connections for any leakage of fuel.**

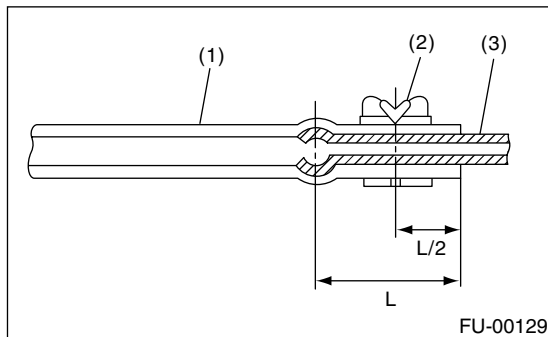

- (1) Hose
- (2) Clip
- (3) Pipe

## C: INSPECTION

1) Make sure there are no cracks on fuel pipes and fuel hoses.

2) Make sure the fuel pipe and fuel hose connections are tightened firmly.



# Fuel System Trouble in General

FUEL INJECTION (FUEL SYSTEMS)

## 26. Fuel System Trouble in General

### A: INSPECTION

Trouble and possible cause		Corrective action
<b>1. Insufficient fuel supply to injector</b>		
1)	Fuel pump will not operate.	
	○ Defective terminal contact.	Inspect connections, especially ground, and tighten securely.
	○ Trouble in electromagnetic or electronic circuit parts.	Replace the fuel pump.
2)	Lowering of fuel pump function.	Replace the fuel pump.
3)	Clogged dust or water in fuel filter.	Replace the fuel filter, clean or replace fuel tank.
4)	Clogged or bent fuel pipe or hose.	Clean, correct or replace the fuel pipe or hose.
5)	Air is mixed in fuel system.	Inspect or retighten each connection part.
6)	Clogged or bent breather tube or pipe.	Clean, correct or replace the air breather tube or pipe.
7)	Damaged diaphragm of pressure regulator.	Replace.
<b>2. Leakage or blow out fuel</b>		
1)	Loosened joints of fuel pipe.	Retightening.
2)	Cracked fuel pipe, hose and fuel tank.	Replace.
3)	Defective welding part on fuel tank.	Replace.
4)	Defective drain packing of fuel tank.	Replace.
5)	Clogged or bent air breather tube or air vent tube.	Clean, correct or replace the air breather tube or air vent tube.
<b>3. Gasoline smell inside of compartment</b>		
1)	Loose joints at air breather tube, air vent tube and fuel filler pipe.	Retightening.
2)	Defective packing air tightness on fuel saucer.	Correct or replace the packing.
3)	Cracked fuel separator.	Replace the separator.
4)	Inoperative fuel pump modulator or circuit.	Replace.
<b>4. Defective fuel meter indicator</b>		
1)	Defective operation of fuel meter unit.	Replace.
2)	Defective operation of fuel meter.	Replace.
<b>5. Noise</b>		
1)	Large operation noise or vibration of fuel pump.	Replace.

#### NOTE:

- When the vehicle is left unattended for an extended period of time, water may accumulate in the fuel tank. To prevent water condensation.

(1) Top off the fuel tank or drain the fuel completely.

(2) Drain water condensation from the fuel filter.

- Refilling the fuel tank.

Refill the fuel tank while there is still some fuel left in the tank.

- Protecting the fuel system against freezing and water condensation.

(3) Cold areas

In snow-covered areas, mountainous areas, skiing areas, etc. where ambient temperatures drop below 0°C (32°F) throughout the winter season, use an anti-freeze solution in the cooling system. Refueling will also complement the effect of anti-freeze solution each time the fuel level drops to about one-half. After the winter season, drain water which may have accumulated in the fuel filter and fuel tank in the manner same as that described under "Affected areas" below.

(4) Affected areas

When water condensation is notched in the fuel filter, drain water from both the fuel filter and fuel tank or use a water removing agent (or anti-freeze solution) in the fuel tank.

- Observe the instructions, notes, etc., indicated on the label affixed to the anti-freeze solution (water removing agent) container before use.

# Fuel System Trouble in General

FUEL INJECTION (FUEL SYSTEMS)

---