

ENGINE SECTION 1

This service manual has been prepared to provide SUBARU service personnel with the necessary information and data for the correct maintenance and repair of SUBARU vehicles. This manual includes the procedures for maintenance, disassembling, reassembling, inspection and adjustment of components and diagnostics for guidance of experienced mechanics. Please peruse and utilize this manual fully to ensure complete repair work for satisfying our customers by keeping their vehicle in optimum condition. When replacement of parts during repair work is needed, be sure to use SUBARU genuine parts.

All information, illustration and specifications contained in this manual are based on the latest product information available at the time of publication approval.

FUEL INJECTION (FUEL SYSTEMS)	FU(H4SO)
EMISSION CONTROL (AUX. EMISSION CONTROL DEVICES)	EC(H4SO)
INTAKE (INDUCTION)	IN(H4SO)
MECHANICAL	ME(H4SO)
EXHAUST	EX(H4SO)
COOLING	CO(H4SO)
LUBRICATION	LU(H4SO)
SPEED CONTROL SYSTEMS	SP(H4SO)
IGNITION	IG(H4SO)
STARTING/CHARGING SYSTEMS	SC(H4SO)
ENGINE (DIAGNOSTICS)	EN(H4SO)(diag)
FUEL INJECTION (FUEL SYSTEMS)	FU(H4SOw/oOBD)
EMISSION CONTROL (AUX. EMISSION CONTROL DEVICES)	EC(H4SOw/oOBD)
INTAKE (INDUCTION)	IN(H4SOw/oOBD)
MECHANICAL	ME(H4SOw/oOBD)
EXHAUST	EX(H4SOw/oOBD)
COOLING	CO(H4SOw/oOBD)

ENGINE SECTION 1

LUBRICATION

LU(H4SOw/oOBD)

SPEED CONTROL SYSTEMS

SP(H4SOw/oOBD)

IGNITION

IG(H4SOw/oOBD)

STARTING/CHARGING SYSTEMS

SC(H4SOw/oOBD)

ENGINE (DIAGNOSTICS)

EN(H4SOw/oOBD)
(diag)

MECHANICAL

ME(H4SO)

	Page
1. General Description	2
2. Compression	26
3. Idle Speed	27
4. Ignition Timing	28
5. Intake Manifold Vacuum.....	29
6. Engine Oil Pressure	30
7. Fuel Pressure	31
8. Valve Clearance	32
9. Engine Assembly	34
10. Engine Mounting	41
11. Preparation for Overhaul.....	42
12. V-belt.....	43
13. Crankshaft Pulley	45
14. Timing Belt Cover.....	47
15. Timing Belt Assembly.....	48
16. Camshaft Sprocket.....	53
17. Crankshaft Sprocket.....	55
18. Valve Rocker Assembly	56
19. Camshaft.....	58
20. Cylinder Head Assembly.....	62
21. Cylinder Block	68
22. Engine Trouble in General	89
23. Engine Noise	95

13. Crankshaft Pulley

A: REMOVAL

1) Remove the V-belt. <Ref. to ME(H4SO)-43, REMOVAL, V-belt.>

2) Remove the crankshaft pulley bolt. To lock the crankshaft, use ST.

ST 499977400 CRANKSHAFT PULLEY WRENCH (1.6 L and 2.0 L model)

ST 499977100 CRANKSHAFT PULLEY WRENCH (2.5 L model)

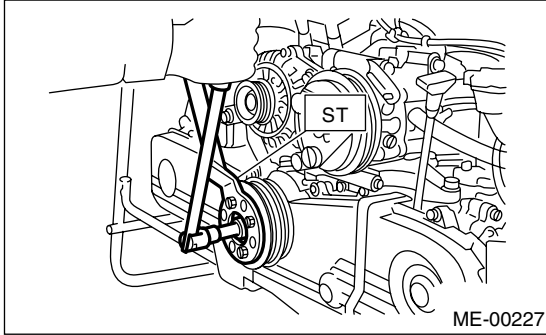

3) Remove the crankshaft pulley.

B: INSTALLATION

1. 1.6 L AND 2.0 L MODEL

1) Install the crankshaft pulley.

2) Install the pulley bolt.

To lock the crankshaft, use ST.

ST 499977400 CRANKSHAFT PULLEY WRENCH

(1) Clean the crankshaft pulley thread using an air gun.

(2) Apply engine oil to the crankshaft pulley bolt seat and thread.

(3) Tighten the bolts temporarily with tightening torque of 44 N·m (4.5 kgf·m, 33 ft·lb).

(4) Tighten the crankshaft pulley bolts.

Tightening torque:

127 N·m (13.0 kgf·m, 94.0 ft·lb)

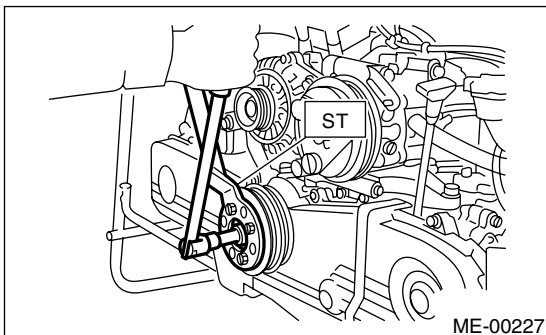

3) Confirm that the tightening angle of crankshaft pulley bolt is 45 degrees or more. If the tightening angle of crankshaft pulley bolt is less than 45 degrees, conduct the following procedures.

(1) Replace the crankshaft pulley bolts and clean them.

Crankshaft pulley bolt:

12369AA011

(2) Clean the crankshaft thread using an air gun.

(3) Apply engine oil to the crankshaft pulley bolt seal and thread.

(4) Tighten the bolts temporarily with tightening torque of 44 N·m (4.5 kgf·m, 33 ft·lb).

(5) Tighten the crankshaft pulley bolts keeping them in an angle between 45 degrees and 60 degrees.

NOTE:

Conduct the tightening procedures by confirming the turning angle of crankshaft pulley bolt referring to the gauge indicated on timing belt cover.

4) Install the belt tensioner.

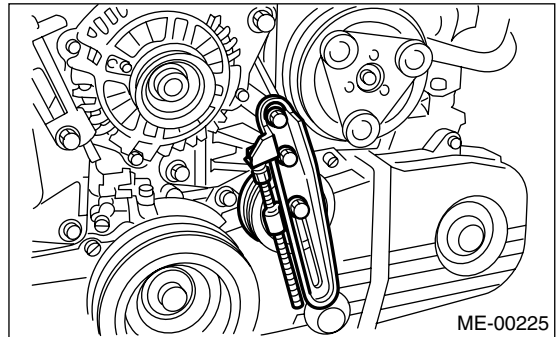

5) Install the V-belt. <Ref. to ME(H4SO)-43, INSTALLATION, V-belt.>

2. 2.5 L MODEL

1) Install the crankshaft pulley.

2) Install the pulley bolt.

To lock the crankshaft, use ST.

ST 499977100 CRANKSHAFT PULLEY WRENCH

(1) Clean the crankshaft pulley thread using an air gun.

(2) Apply engine oil to the crankshaft pulley bolt seat and thread.

(3) Tighten the bolts temporarily with tightening torque of 44 N·m (4.5 kgf·m, 33 ft·lb).

(4) Tighten the crankshaft pulley bolts.

Crankshaft Pulley

MECHANICAL

Tightening torque:

177 N·m (18.0 kgf·m, 130.2 ft·lb)

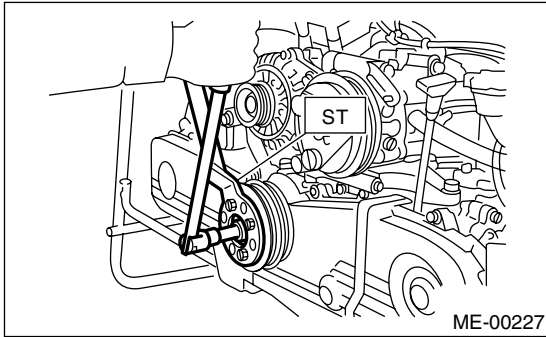

3) Confirm that the tightening angle of crankshaft pulley bolt is 65 degrees or more. If the tightening angle of crankshaft pulley bolt is less than 65 degrees, conduct the following procedures.

(1) Replace the crankshaft pulley bolts and clean them.

Crankshaft pulley bolt:

12369AA011

(2) Clean the crankshaft thread using an air gun.

(3) Apply engine oil to the crankshaft pulley bolt seal and thread.

(4) Tighten the bolts temporarily with tightening torque of 44 N·m (4.5 kgf·m, 33 ft·lb).

(5) Tighten the crankshaft pulley bolts keeping them in an angle between 65 degrees and 75 degrees.

NOTE:

Conduct the tightening procedures by confirming the turning angle of crankshaft pulley bolt referring to the gauge indicated on timing belt cover.

4) Install the A/C belt tensioner.

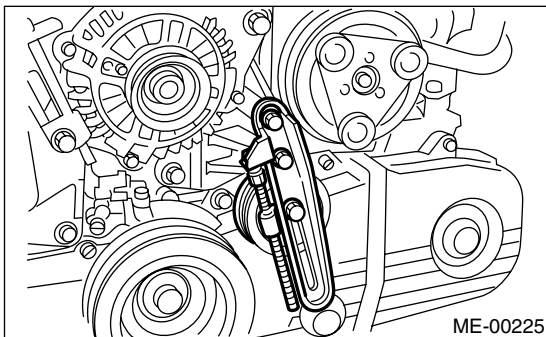

5) Install the V-belt. <Ref. to ME(H4SO)-43, INSTALLATION, V-belt.>

C: INSPECTION

1) Make sure the V-belt is not worn or otherwise damaged.

2) Check the tension of the belt. <Ref. to ME(H4SO)-44, INSPECTION, V-belt.>

14. Timing Belt Cover

A: REMOVAL

- 1) Remove the V-belt. <Ref. to ME(H4SO)-43, REMOVAL, V-belt.>
- 2) Remove the crankshaft pulley. <Ref. to ME(H4SO)-45, REMOVAL, Crankshaft Pulley.>
- 3) Remove the timing belt cover (LH).
- 4) Remove the front timing belt cover.

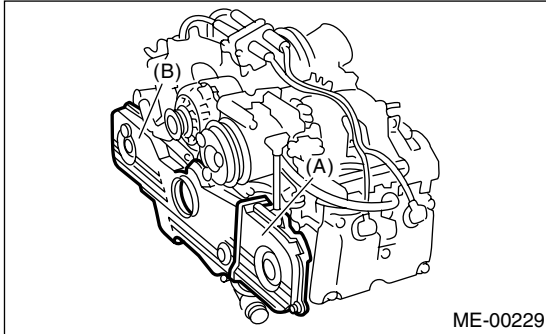

- (A) Timing belt cover (LH)
- (B) Front timing belt cover

B: INSTALLATION

- 1) Install the front timing belt cover.

Tightening torque:

5 N·m (0.5 kgf-m, 3.6 ft-lb)

- 2) Install the timing belt cover (LH).

Tightening torque:

5 N·m (0.5 kgf-m, 3.6 ft-lb)

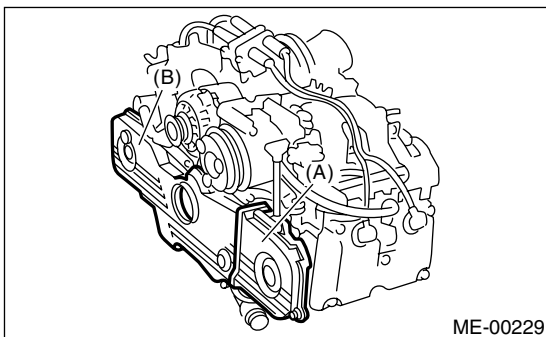

- (A) Timing belt cover (LH)
- (B) Front timing belt cover

- 3) Install the crankshaft pulley. <Ref. to ME(H4SO)-45, INSTALLATION, Crankshaft Pulley.>

- 4) Install the V-belt. <Ref. to ME(H4SO)-43, INSTALLATION, V-belt.>

C: INSPECTION

Make sure the cover is not damaged.

15. Timing Belt Assembly

A: REMOVAL

1. TIMING BELT

- 1) Remove the V-belt. <Ref. to ME(H4SO)-43, REMOVAL, V-belt.>
- 2) Remove the crankshaft pulley. <Ref. to ME(H4SO)-45, REMOVAL, Crankshaft Pulley.>
- 3) Remove the timing belt cover. <Ref. to ME(H4SO)-47, REMOVAL, Timing Belt Cover.>
- 4) Remove the timing belt guide. (MT model)

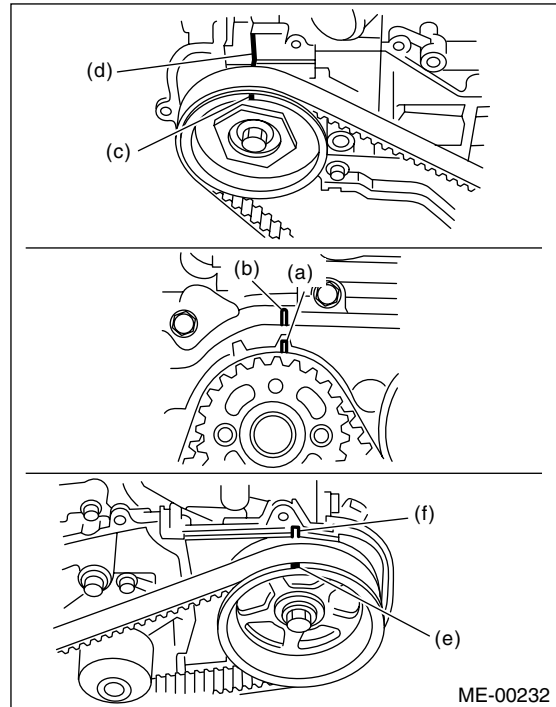
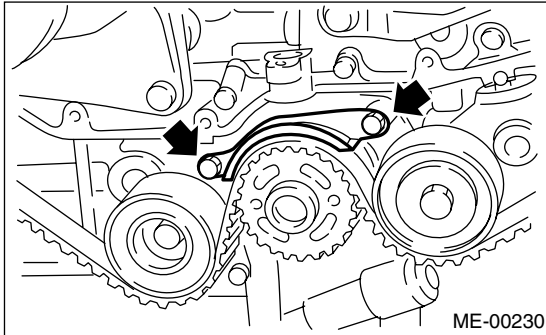

5) If the alignment mark (a) and/or arrow mark (which indicates rotation direction) on timing belt fade away, put new marks before removing the timing belt as shown in procedures below.

(2) Using white paint, put alignment and/or arrow marks on the timing belts in relation to crank sprocket and cam sprockets.

- (1) Turn the crankshaft using ST. Align the mark (a) of sprocket to cylinder block notch (b) and ensure the right side cam sprocket mark (c), cam cap and cylinder head matching surface (d) and/or left side cam sprocket mark (e) and timing belt cover notch (f) are properly adjusted.

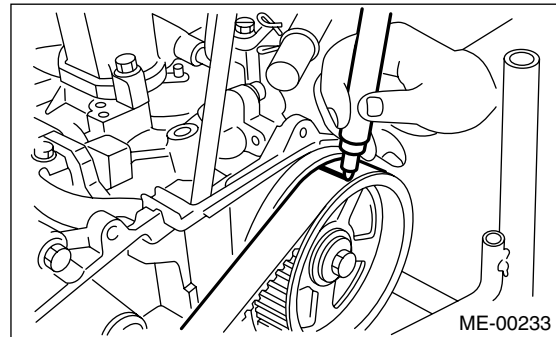

ST 499987500 CRANKSHAFT SOCKET

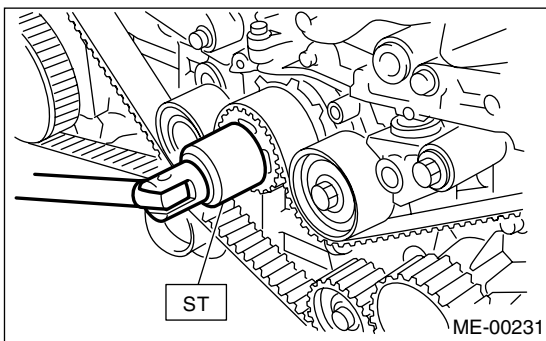

Specified data:

Z_1 : 46.8 tooth length

Z_2 : 43.7 tooth length

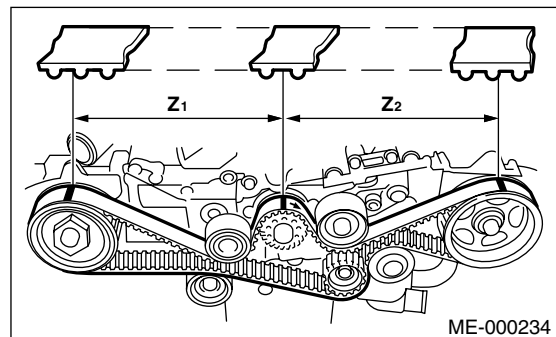

6) Remove the belt idler (No. 2).

7) Remove the belt idler No. 2.

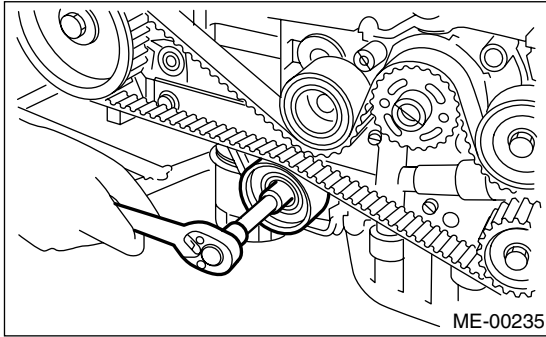

8) Remove the timing belt.

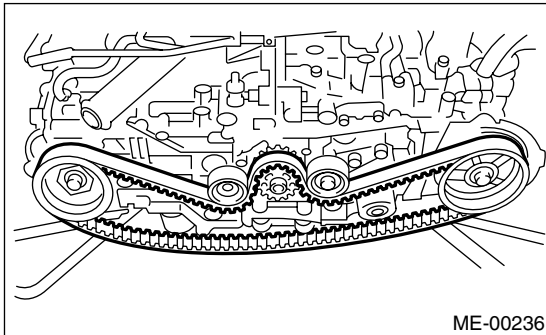

2. BELT IDLER AND AUTOMATIC BELT TENSION ADJUSTER ASSEMBLY

1) Remove the belt idler (No. 1).

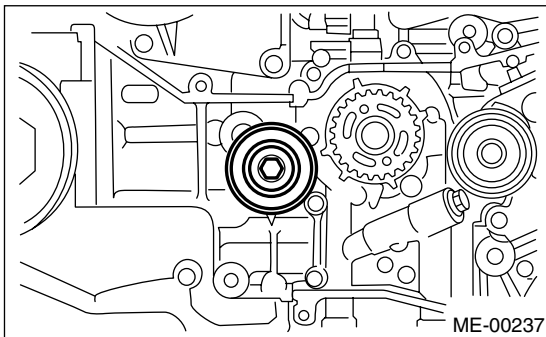

2) Remove the automatic belt tension adjuster assembly.

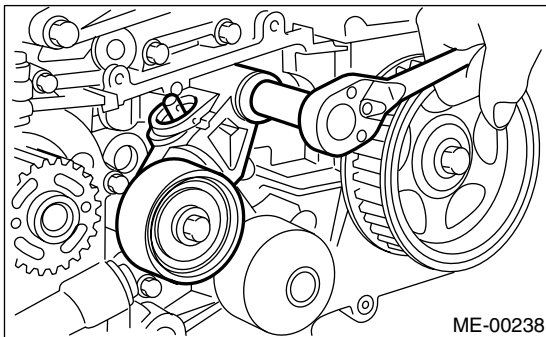

B: INSTALLATION

1. AUTOMATIC BELT TENSION ADJUSTER ASSEMBLY AND BELT IDLER

1) Preparation for installation of automatic belt tension adjuster assembly;

CAUTION:

- Always use a vertical type pressing tool to move the adjuster rod down.
- Do not use a lateral type vise.
- Push the adjuster rod vertically.
- Press-in the push adjuster rod gradually taking more than 3 minutes.
- Do not allow press pressure to exceed 9,807 N (1,000 kgf, 2,205 lb).
- Press the adjuster rod as far as the end surface of cylinder. Do not press the adjuster rod into the cylinder. Doing so may damage the cylinder.
- Do not release the press pressure until stopper pin is completely inserted.

(1) Attach the automatic belt tension adjuster assembly to the vertical pressing tool.

(2) Slowly move the adjuster rod down with a pressure of 294 N (30 kgf, 66 lb) until the adjuster rod is aligned with the stopper pin hole in the cylinder.

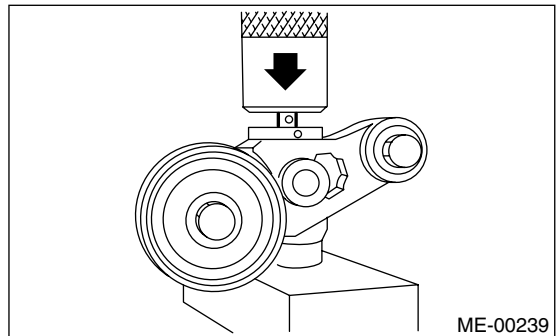

(3) With a 2 mm (0.08 in) dia. stopper pin or a 2 mm (0.08 in) (nominal) dia. hex bar wrench inserted into the stopper pin hole in the cylinder, secure the adjuster rod.

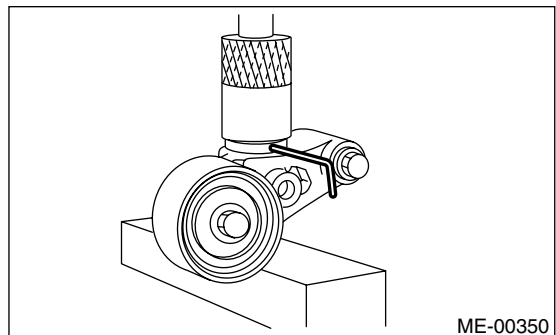

2) Install the automatic belt tension adjuster assembly.

Timing Belt Assembly

MECHANICAL

Tightening torque:
39 N·m (4.0 kgf-m, 28.9 ft-lb)

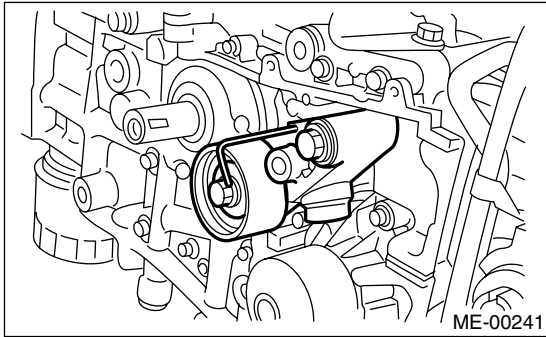

3) Install the belt idler (No. 1).

Tightening torque:
39 N·m (4.0 kgf-m, 28.9 ft-lb)

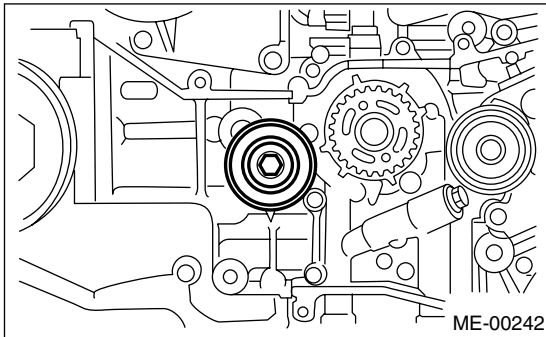

2. TIMING BELT

1) Preparation for the installation of automatic belt tension adjuster assembly. <Ref. to ME(H4SO)-49, AUTOMATIC BELT TENSION ADJUSTER ASSEMBLY AND BELT IDLER, INSTALLATION, Timing Belt Assembly.>

2) Installation of timing belt

(1) Turn the camshaft sprocket No. 2 using ST1, and then turn the camshaft sprocket No. 1 using ST2 so that their alignment marks (A) come to top positions.

ST1 18231AA010 CAMSHAFT SPROCKET WRENCH

NOTE:

Also the CAMSHAFT SPROCKET WRENCH (499207100) can be used.

ST2 499207400 CAMSHAFT SPROCKET WRENCH

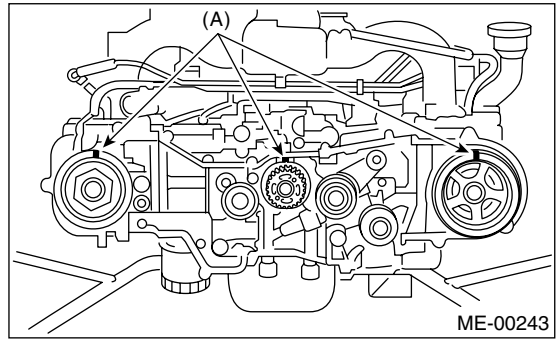

(2) While aligning alignment marks (B) on the timing belt with marks (A) on sprockets, position the timing belt properly.

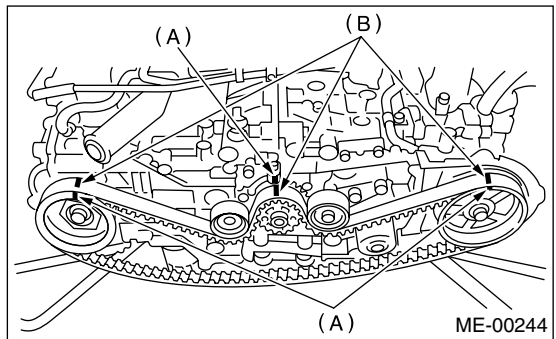

3) Install the belt idler No. 2.

Tightening torque:
39 N·m (4.0 kgf-m, 28.9 ft-lb)

4) Install the belt idler (No. 2).

Tightening torque:
39 N·m (4.0 kgf-m, 28.9 ft-lb)

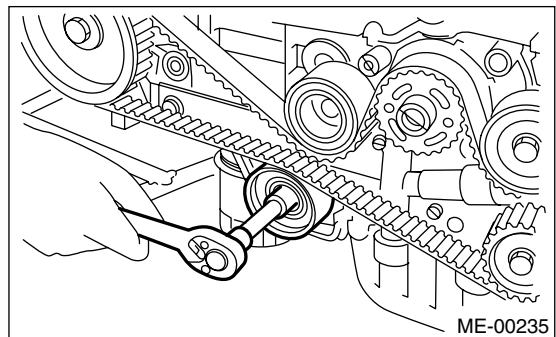

5) After ensuring that the marks on timing belt and camshaft sprockets are aligned, remove the stopper pin from belt tension adjuster.

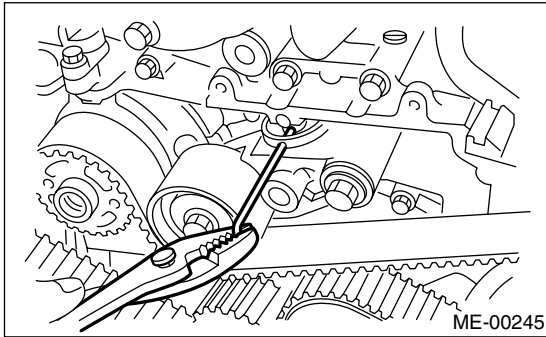

6) Install the timing belt guide. (MT model)
 (1) Temporarily tighten the timing belt guide mounting bolts.

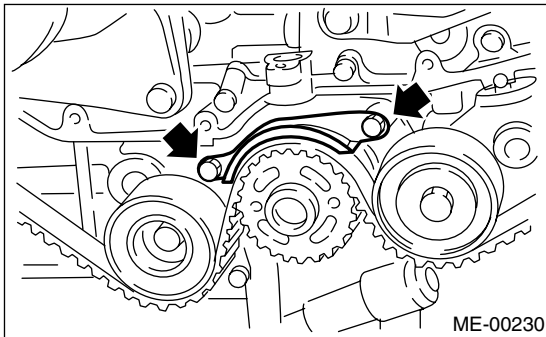

(2) Check and adjust the clearance between timing belt and timing belt guide by using thickness gauge.

Clearance:
 $1.0 \pm 0.5 \text{ mm (0.039} \pm 0.020 \text{ in)}$

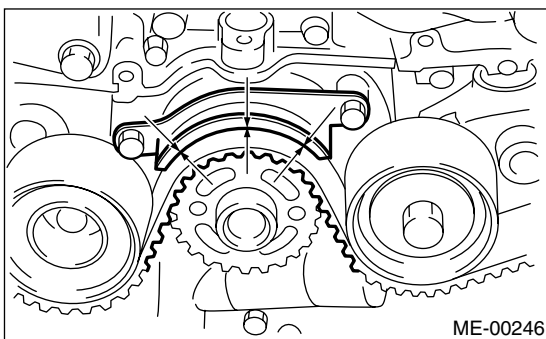

(3) Tighten the timing belt guide mounting bolts.

Tightening torque:
 $10 \text{ N}\cdot\text{m (1.0 kgf}\cdot\text{m, 7.2 ft}\cdot\text{lb)}$

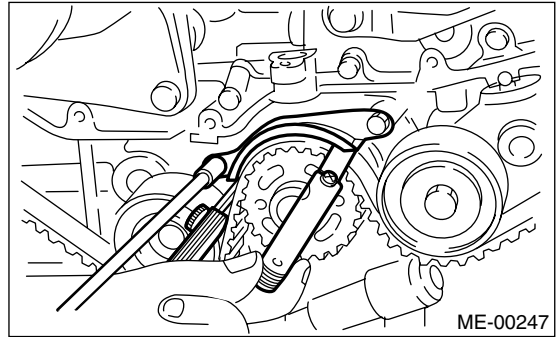

7) Install the timing belt cover. <Ref. to ME(H4SO)-47, INSTALLATION, Timing Belt Cover.>
 8) Install the crankshaft pulley. <Ref. to ME(H4SO)-45, REMOVAL, Crankshaft Pulley.>
 9) Install the V-belt. <Ref. to ME(H4SO)-43, INSTALLATION, V-belt.>

C: INSPECTION

1. TIMING BELT

- 1) Check the timing belt teeth for breaks, cracks, and wear. If any fault is found, replace the belt.
- 2) Check the condition of back side of belt; if any crack is found, replace the belt.

CAUTION:

- Be careful not to let oil, grease or coolant contact the belt. Remove quickly and thoroughly if this happens.
- Do not bend the belt sharply.

Bending radius: h
 $60 \text{ mm (2.36 in) or more}$

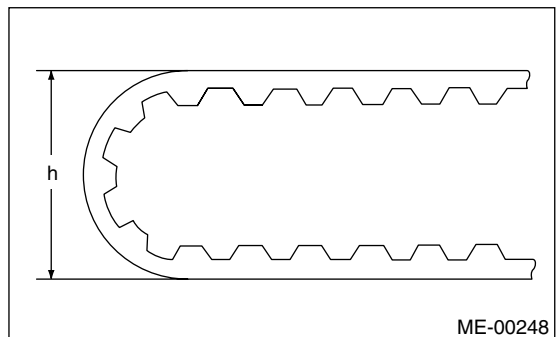

2. AUTOMATIC BELT TENSION ADJUSTER

- 1) Visually check oil seals for leaks, and rod ends for abnormal wear or scratches. If necessary, replace faulty parts.
- 2) Check that the adjuster rod does not move when a pressure of 294 N (30 kgf, 66 lb) is applied to it. This is to check adjuster rod stiffness.

Timing Belt Assembly

MECHANICAL

3) If the adjuster rod is not stiff and moves freely when applying 294 N (30 kgf, 66 lb), check it using the following procedures:

(1) Slowly press the adjuster rod down to the end surface of the cylinder. Repeat this motion 2 or 3 times.

(2) With the adjuster rod moved all the way up, apply a pressure of 294 N (30 kgf, 66 lb) to it. Check adjuster rod stiffness.

(3) If the adjuster rod is not stiff and moves down, replace the automatic belt tension adjuster assembly with a new one.

2) Check the belt outer contacting surfaces of idler pulley for abnormal wear and scratches.

3) Check the belt idler for grease leakage.

CAUTION:

- Always use a vertical type pressing tool to move the adjuster rod down.
- Do not use a lateral type vise.
- Push the adjuster rod vertically.
- Press-in the adjuster rod gradually taking more than 3 minutes.
- Do not allow press pressure to exceed 9,807 N (1,000 kgf, 2,205 lb).
- Press the adjuster rod as far as the end surface of the cylinder. Do not press the adjuster rod into the cylinder. Doing so may damage the cylinder.

4) Measure the extension of rod beyond the body. If it is not within specifications, replace with a new one.

Rod extension: H

5.7 ± 0.5 mm (0.224 ± 0.020 in)

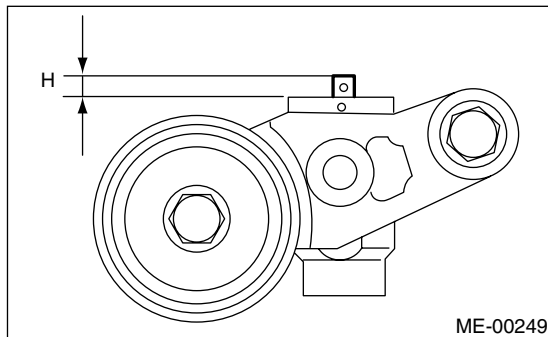

3. BELT TENSION PULLEY

1) Check the mating surfaces of timing belt and contact point of adjuster rod for abnormal wear or scratches. Replace the automatic belt tension adjuster assembly if faulty.

2) Check the tension pulley for smooth rotation. Replace if noise or excessive play is noted.

3) Check the tension pulley for grease leakage.

4. BELT IDLER

1) Check the belt idler for smooth rotation. Replace if noise or excessive play is noted.

16. Camshaft Sprocket

A: REMOVAL

1. REMOVAL

- 1) Remove the V-belt. <Ref. to ME(H4SO)-43, REMOVAL, V-belt.>
- 2) Remove the crankshaft pulley. <Ref. to ME(H4SO)-45, REMOVAL, Crankshaft Pulley.>
- 3) Remove the timing belt cover. <Ref. to ME(H4SO)-47, REMOVAL, Timing Belt Cover.>
- 4) Remove the timing belt assembly. <Ref. to ME(H4SO)-48, REMOVAL, Timing Belt Assembly.>
- 5) Remove the camshaft position sensor. <Ref. to FU(H4SO)-29, REMOVAL, Camshaft Position Sensor.>
- 6) Remove the camshaft sprocket No. 2. To lock the camshaft, use ST.

ST 18231AA010 CAMSHAFT SPROCKET WRENCH

NOTE:

Also the CAMSHAFT SPROCKET WRENCH (499207100) can be used.

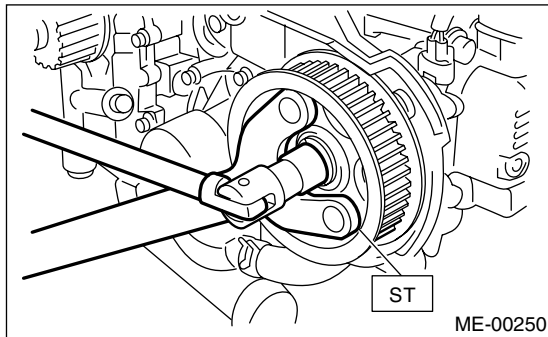

- 7) Remove the camshaft sprocket No. 1. To lock the camshaft, use ST.

ST 499207400 CAMSHAFT SPROCKET WRENCH

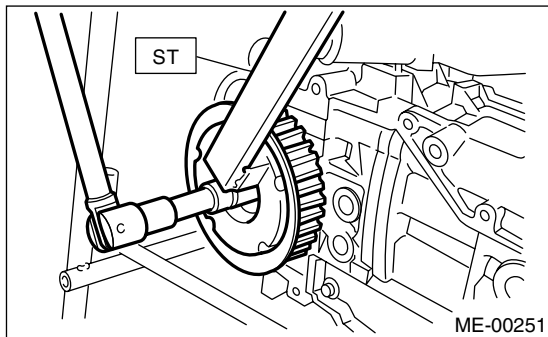

B: INSTALLATION

- 1) Install the camshaft sprocket No. 1. To lock the camshaft, use ST.

ST 499207400 CAMSHAFT SPROCKET WRENCH

Tightening torque:

78 N·m (8.0 kgf·m, 57.9 ft·lb)

NOTE:

Do not confuse the right and left side camshaft sprockets during installation. The camshaft sprocket No. 2 is identified by a projection used to monitor camshaft position sensor.

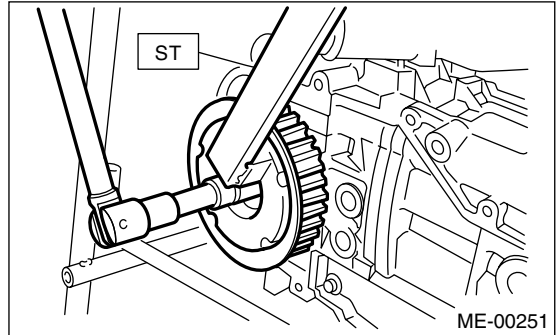

- 2) Install the camshaft sprocket No. 2. To lock camshaft, use ST.

ST 18231AA010 CAMSHAFT SPROCKET WRENCH

NOTE:

Also the CAMSHAFT SPROCKET WRENCH (499207100) can be used.

Tightening torque:

78 N·m (8.0 kgf·m, 57.9 ft·lb)

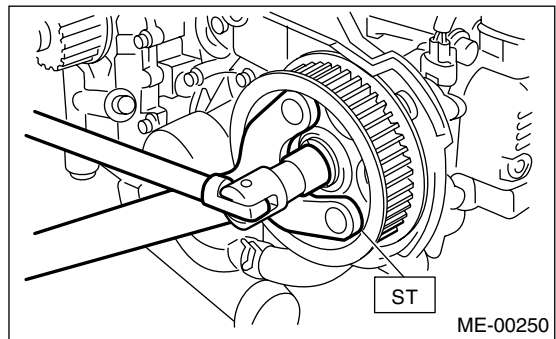

- 3) Install the camshaft position sensor. <Ref. to FU(H4SO)-29, INSTALLATION, Camshaft Position Sensor.>

- 4) Install the timing belt assembly. <Ref. to ME(H4SO)-49, INSTALLATION, Timing Belt Assembly.>

- 5) Install the timing belt cover. <Ref. to ME(H4SO)-47, INSTALLATION, Timing Belt Cover.>

- 6) Install the crankshaft pulley. <Ref. to ME(H4SO)-45, INSTALLATION, Crankshaft Pulley.>

- 7) Install the V-belt. <Ref. to ME(H4SO)-43, INSTALLATION, V-belt.>

C: INSPECTION

- 1) Check the sprocket teeth for abnormal wear and scratches.

Camshaft Sprocket

MECHANICAL

- 2) Make sure there is no free play between sprocket and key.
- 3) Check the camshaft sprocket notch for sensor for damage and contamination of foreign matter.

17. Crankshaft Sprocket

A: REMOVAL

- 1) Remove the V-belt. <Ref. to ME(H4SO)-43, REMOVAL, V-belt.>
- 2) Remove the crankshaft pulley. <Ref. to ME(H4SO)-45, REMOVAL, Crankshaft Pulley.>
- 3) Remove the timing belt cover. <Ref. to ME(H4SO)-47, REMOVAL, Timing Belt Cover.>
- 4) Remove the timing belt assembly. <Ref. to ME(H4SO)-48, REMOVAL, Timing Belt Assembly.>
- 5) Remove the camshaft sprocket. <Ref. to ME(H4SO)-53, REMOVAL, Camshaft Sprocket.>
- 6) Remove the crankshaft sprocket.

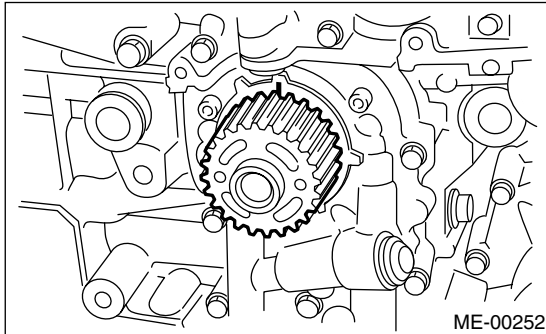

B: INSTALLATION

- 1) Install the crankshaft sprocket.

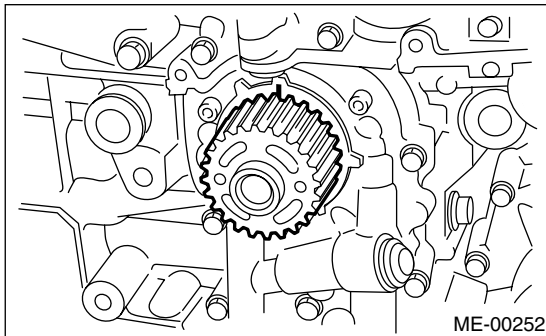

- 2) Install the camshaft sprocket. <Ref. to ME(H4SO)-53, INSTALLATION, Camshaft Sprocket.>
- 3) Install the timing belt assembly. <Ref. to ME(H4SO)-49, INSTALLATION, Timing Belt Assembly.>
- 4) Install the timing belt cover. <Ref. to ME(H4SO)-47, INSTALLATION, Timing Belt Cover.>
- 5) Install the crankshaft pulley. <Ref. to ME(H4SO)-45, INSTALLATION, Crankshaft Pulley.>
- 6) Install the V-belt. <Ref. to ME(H4SO)-43, INSTALLATION, V-belt.>

C: INSPECTION

- 1) Check the sprocket teeth for abnormal wear and scratches.

- 2) Make sure there is no free play between sprocket and key.
- 3) Check the crankshaft sprocket notch for sensor for damage and contamination of foreign matter.

Valve Rocker Assembly

MECHANICAL

18. Valve Rocker Assembly

A: REMOVAL

- 1) Remove the V-belt. <Ref. to ME(H4SO)-43, REMOVAL, V-belt.>
- 2) Remove the crankshaft pulley. <Ref. to ME(H4SO)-45, REMOVAL, Crankshaft Pulley.>
- 3) Remove the timing belt cover. <Ref. to ME(H4SO)-47, REMOVAL, Timing Belt Cover.>
- 4) Remove the timing belt assembly. <Ref. to ME(H4SO)-48, REMOVAL, Timing Belt Assembly.>
- 5) Remove the camshaft sprocket. <Ref. to ME(H4SO)-53, REMOVAL, Camshaft Sprocket.>
- 6) Disconnect the PCV hose and remove rocker cover.
- 7) Removal of valve rocker assembly
 - (1) Remove the bolts (a) through (h) in alphabetical sequence.

NOTE:

Leave two or three threads of bolts (g and h) engaged to retain the valve rocker assembly.

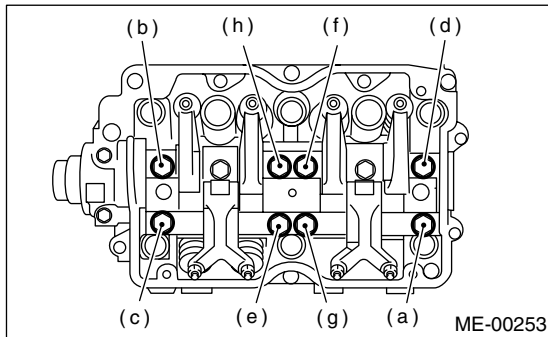

- (2) Remove the valve rocker assembly.

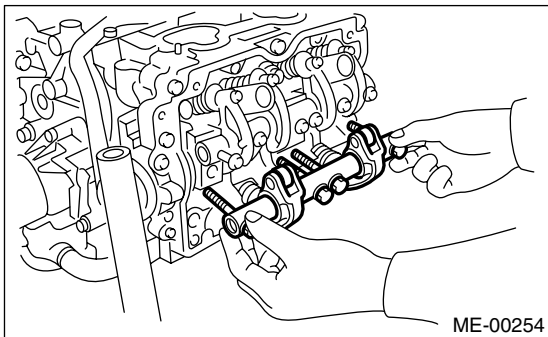

B: INSTALLATION

- 1) Installation of valve rocker assembly
 - (1) Temporarily tighten the bolts (a) through (d) equally as shown in the figure.

NOTE:

Do not allow the valve rocker assembly to gouge knock pins.

- (2) Tighten the bolts (e) through (h) to specified torque.

- (3) Tighten the bolts (a) through (d) to specified torque.

Tightening torque:

25 N·m (2.5 kgf·m, 18.1 ft·lb)

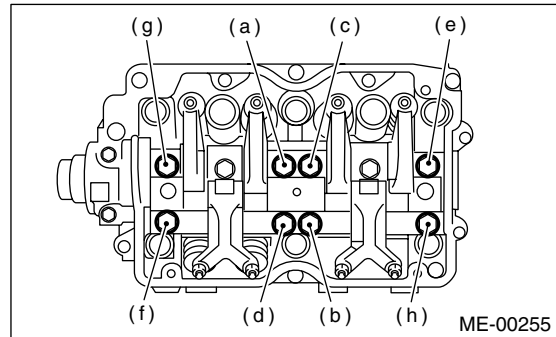

- 2) Adjust the valve clearances. <Ref. to ME(H4SO)-33, ADJUSTMENT, Valve Clearance.>
- 3) Install the rocker cover and connect PCV hose.
- 4) Install the camshaft sprocket. <Ref. to ME(H4SO)-53, INSTALLATION, Camshaft Sprocket.>
- 5) Install the timing belt assembly. <Ref. to ME(H4SO)-49, INSTALLATION, Timing Belt Assembly.>
- 6) Install the timing belt cover. <Ref. to ME(H4SO)-47, INSTALLATION, Timing Belt Cover.>
- 7) Install the crankshaft pulley. <Ref. to ME(H4SO)-45, INSTALLATION, Crankshaft Pulley.>
- 8) Install the V-belt. <Ref. to ME(H4SO)-43, INSTALLATION, V-belt.>

C: DISASSEMBLY

- 1) Remove the bolts which secure the rocker shaft.
- 2) Extract the rocker shaft. Remove the valve rocker arms, springs and shaft supports from rocker shaft.

NOTE:

Arrange all removed parts in order so that they can be installed in their original positions.

- 3) Remove the nut and adjuster screw from valve rocker.

D: ASSEMBLY

- 1) Install the adjuster screw and nut to valve rocker.
- 2) Arrange the valve rocker arms, springs and shaft supports in assembly order and insert valve rocker shaft.

Tightening torque (Shaft supports installing bolts):

5 N·m (0.5 kgf·m, 3.6 ft·lb)

NOTE:

Valve rocker arms, rocker shaft and shaft supports have identification marks. Ensure the parts with same markings are properly assembled.

3) Install the valve rocker shaft securing bolts.

E: INSPECTION

1. VALVE ROCKER ARM AND ROCKER SHAFT

1) Measure the inside diameter of valve rocker arm and outside diameter of valve rocker shaft, and determine the difference between the two (= oil clearance).

Clearance between arm and shaft:

Standard

0.020 — 0.054 mm (0.0008 — 0.0021 in)

Limit

0.10 mm (0.0039 in)

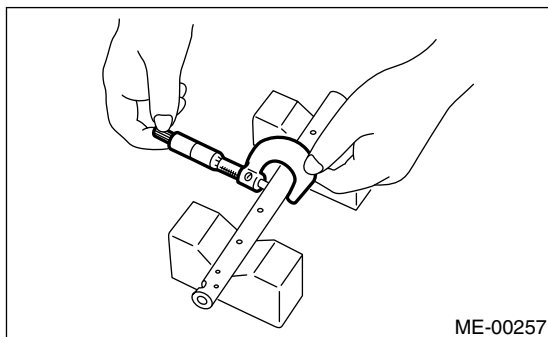
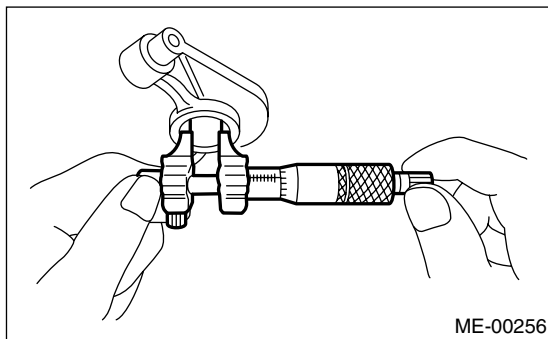

2) If oil clearance exceeds the limit, replace the valve rocker arm or shaft, whichever shows greater amount of wear.

Rocker arm inside diameter:

22.020 — 22.041 mm (0.8669 — 0.8678 in)

Rocker shaft diameter:

21.987 — 22.000 mm (0.8656 — 0.8661 in)

3) If cam or valve contact surface of valve rocker arm is worn or dented excessively, replace the valve rocker arm.

4) Check that the valve rocker arm roller rotates smoothly. If not, replace the valve rocker arm.

19. Camshaft

A: REMOVAL

- 1) Remove the V-belt. <Ref. to ME(H4SO)-43, INSTALLATION, V-belt.>
- 2) Remove the crankshaft pulley. <Ref. to ME(H4SO)-45, REMOVAL, Crankshaft Pulley.>
- 3) Remove the timing belt cover. <Ref. to ME(H4SO)-47, REMOVAL, Timing Belt Cover.>
- 4) Remove the timing belt assembly. <Ref. to ME(H4SO)-48, REMOVAL, Timing Belt Assembly.>
- 5) Remove the camshaft sprocket. <Ref. to ME(H4SO)-53, REMOVAL, Camshaft Sprocket.>
- 6) Remove the crankshaft sprocket. <Ref. to ME(H4SO)-55, REMOVAL, Crankshaft Sprocket.>
- 7) Remove the timing belt cover No. 2 (LH).
- 8) Remove the timing belt cover No. 2 (RH).

NOTE:

Do not damage or lose the seal rubber when removing the timing belt covers.

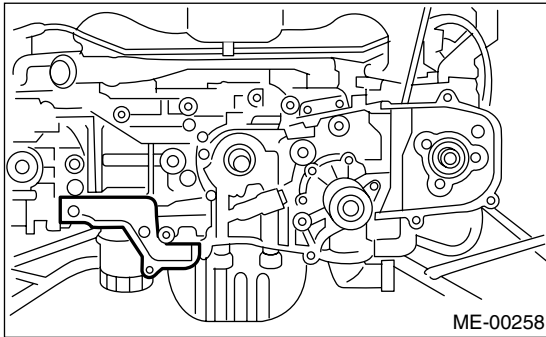

- 9) Remove the tensioner bracket.

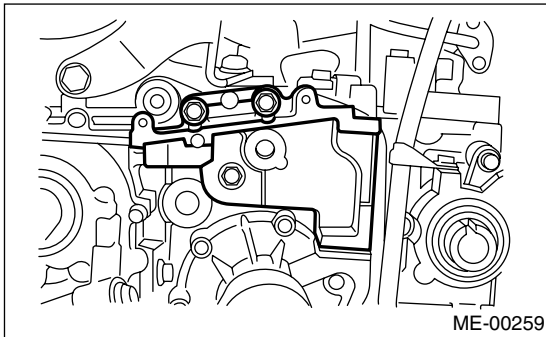

- 10) Remove the camshaft position sensor support. (LH side only)
- 11) Remove the oil level gauge guide. (LH side only)
- 12) Remove the valve rocker assembly. <Ref. to ME(H4SO)-56, REMOVAL, Valve Rocker Assembly.>

- 13) Remove the camshaft cap.

- (1) Remove the bolts (a) through (b) in alphabetical sequence.

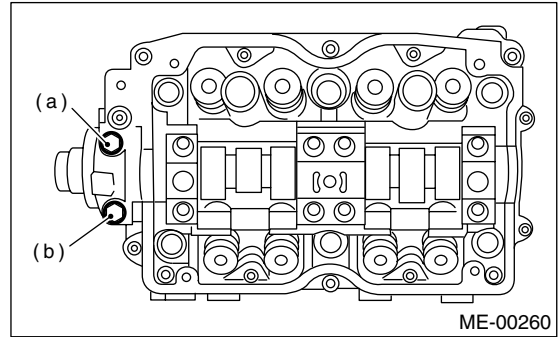

- (2) Equally loosen the bolts (c) through (j) all the way in alphabetical sequence.

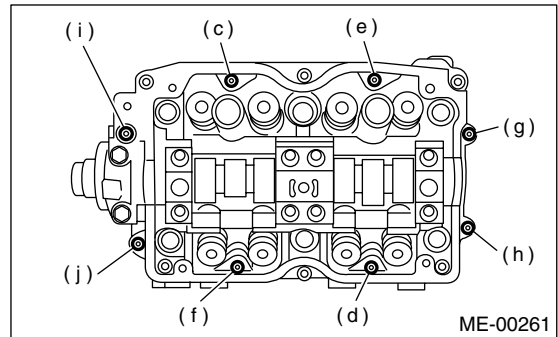

- (3) Remove the bolts (k) through (p) in alphabetical sequence using ST.

ST 499497000 TORX® PLUS

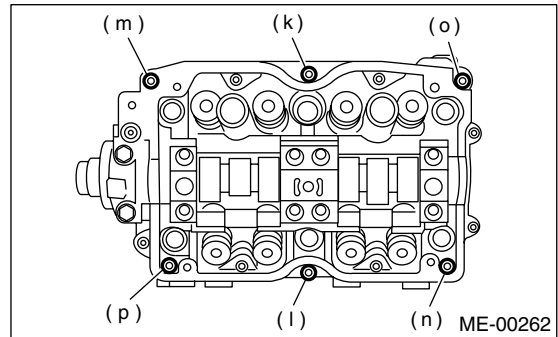

- (4) Remove the camshaft cap.

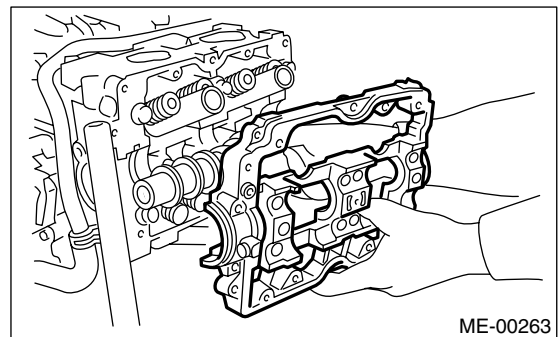

- 14) Remove the camshaft.
- 15) Remove the oil seal.

16) Remove the plug from rear side of camshaft.

CAUTION:

- Do not remove the oil seal unless necessary.
- Do not scratch the journal surface when removing oil seal.

B: INSTALLATION

- 1) Apply a coat of engine oil to the camshaft journals, and then install the camshaft.
- 2) Install the camshaft cap.
 - (1) Apply liquid gasket on the around of camshaft cap.

Liquid gasket:

THREE BOND 1280B

Part No. K0877YA018

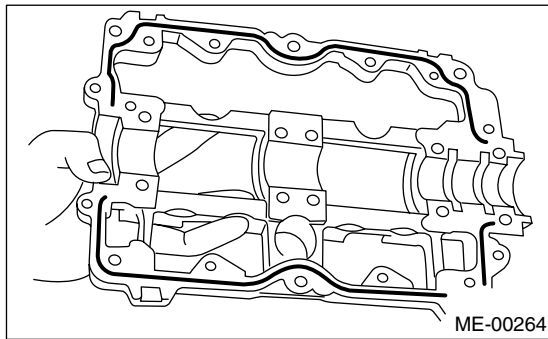

NOTE:

Apply a coat of 3 mm (0.12 in) dia. (A) liquid gasket along edge (B) of the camshaft cap (C) mating surface.

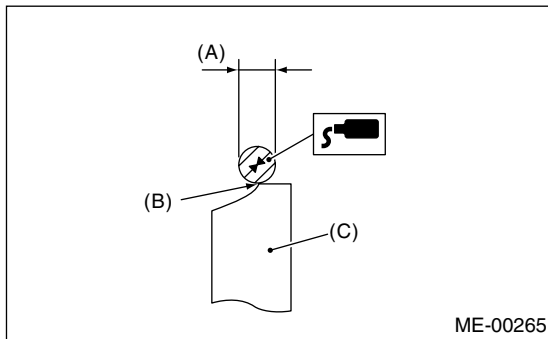

(2) Temporarily tighten the bolts (g) through (j) in alphabetical sequence.

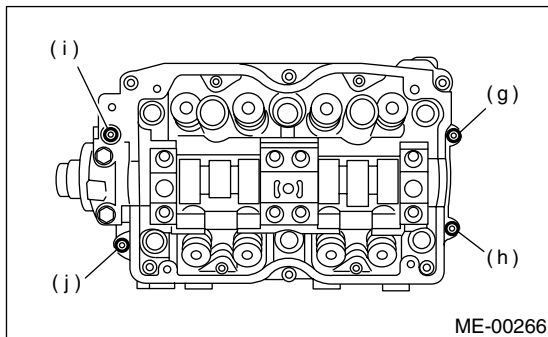

(3) Install the valve rocker assembly.

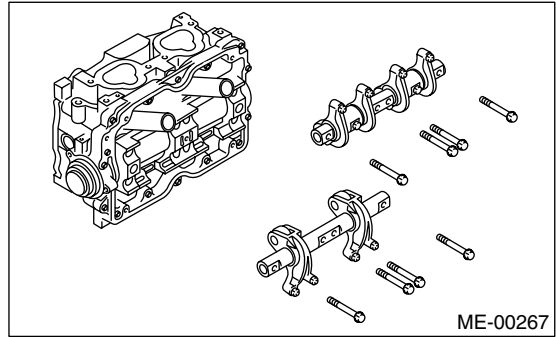

(4) Tighten the bolts (a) through (h) in alphabetical sequence.

Tightening torque:

25 N·m (2.5 kgf·m, 18.1 ft·lb)

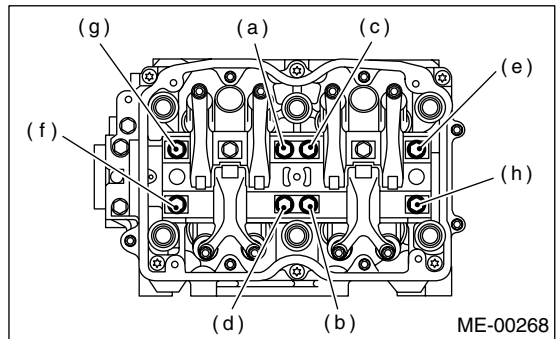

(5) Tighten the TORX® bolts (i) through (n) in alphabetical sequence using ST. ST 499497000 TORX® PLUS

Tightening torque:

18 N·m (1.8 kgf·m, 13.0 ft·lb)

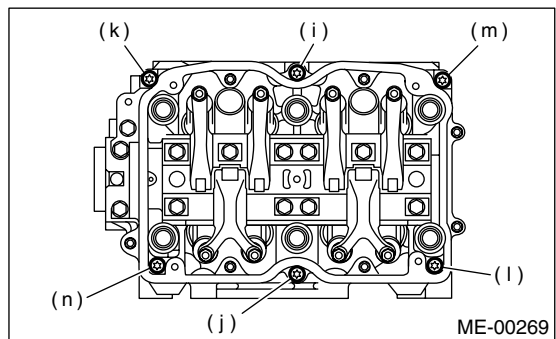

(6) Tighten the bolts (o) through (v) in alphabetical sequence.

Camshaft

MECHANICAL

Tightening torque:

10 N·m (1.0 kgf·m, 7.2 ft·lb)

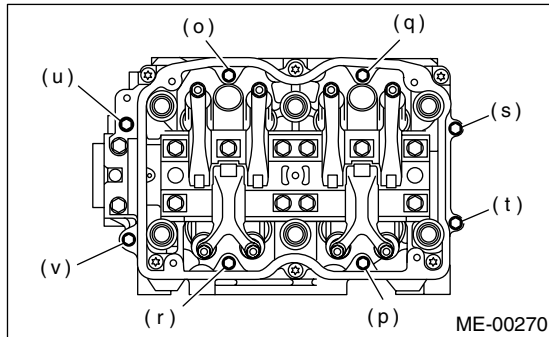

(7) Tighten the bolts (w) through (x) in alphabetical sequence.

Tightening torque:

10 N·m (1.0 kgf·m, 7.2 ft·lb)

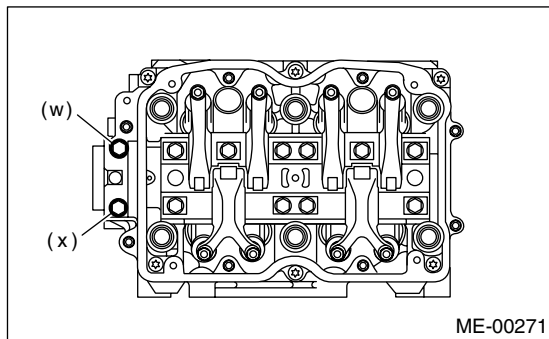

3) Apply a coat of grease to oil seal lips, and then install the oil seal (A) on camshaft using ST1 and ST2.

NOTE:

Use a new oil seal.

ST1 499597000 OIL SEAL GUIDE
ST2 499587500 OIL SEAL INSTALLER

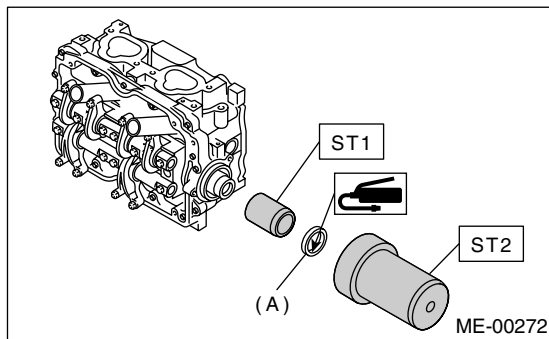

4) Install the plug using ST.
ST 499587700 CAMSHAFT OIL SEAL INSTALLER

5) Adjust the valve clearance. <Ref. to ME(H4SO)-33, ADJUSTMENT, Valve Clearance.>

6) Install the rocker cover and connect PCV hose.

7) Install the oil level gauge guide. (LH side only)

8) Install the camshaft position sensor support. (LH side only)

9) Install the tensioner bracket.

Tightening torque:

25 N·m (2.5 kgf·m, 18.1 ft·lb)

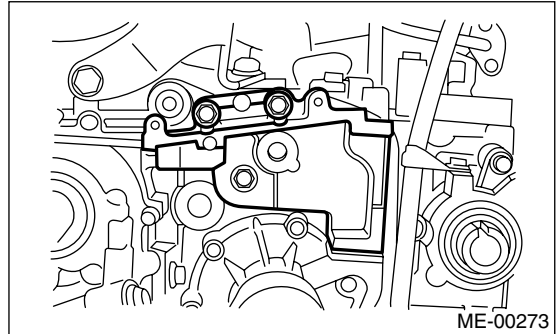

10) Install the timing belt cover No. 2 (RH).

Tightening torque:

5 N·m (0.5 kgf·m, 3.6 ft·lb)

11) Install the timing belt cover No. 2 (LH).

Tightening torque:

5 N·m (0.5 kgf·m, 3.6 ft·lb)

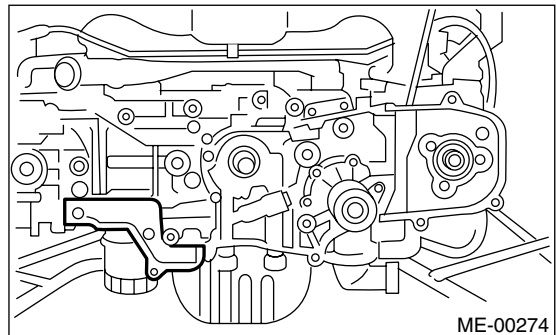

12) Install the crankshaft sprocket. <Ref. to ME(H4SO)-55, INSTALLATION, Crankshaft Sprocket.>

13) Install the camshaft sprocket. <Ref. to ME(H4SO)-53, INSTALLATION, Camshaft Sprocket.>

14) Install the timing belt assembly. <Ref. to ME(H4SO)-49, INSTALLATION, Timing Belt Assembly.>

15) Install the timing belt cover. <Ref. to ME(H4SO)-47, INSTALLATION, Timing Belt Cover.>

16) Install the crankshaft pulley. <Ref. to ME(H4SO)-45, INSTALLATION, Crankshaft Pulley.>

17) Install the V-belt. <Ref. to ME(H4SO)-43, INSTALLATION, V-belt.>

C: INSPECTION

1. CAMSHAFT

1) Measure the bend, and repair or replace if necessary.

Limit:

0.025 mm (0.0010 in)

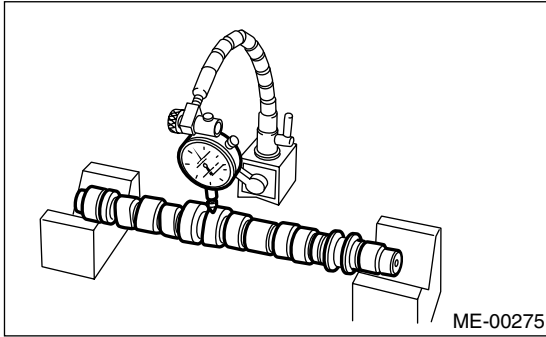

2) Check the journal for damage and wear. Replace if faulty.

3) Measure the outside diameter of camshaft journal and inside diameter of cylinder head journal, and determine the difference between two (= oil clearance). If the oil clearance exceeds specifications, replace the camshaft or cylinder head as necessary.

Unit: mm (in)		
Clearance at journal	Standard	0.055 — 0.090 (0.0022 — 0.0035)
	Limit	0.10 (0.0039)
Camshaft journal O.D.		31.928 — 31.945 (1.2570 — 1.2577)
Journal hole I.D.		32.000 — 32.018 (1.2598 — 1.2605)

4) Check the cam face condition; remove the minor faults by grinding with oil stone. Measure the cam height H; replace if the limit has been exceeded.

Cam height: H

Model	Item	Unit: mm (in)	
1.6 L	Intake	STD	39.378 — 39.478 (1.5503 — 1.5542)
		Limit	39.278 (1.5464)
	Exhaust	STD	39.565 — 39.665 (1.5577 — 1.5616)
		Limit	39.465 (1.5537)
2.0 L	Intake	STD	38.732 — 38.832 (1.5249 — 1.5288)
		Limit	38.632 (1.5209)
	Exhaust	STD	39.257 — 39.357 (1.5455 — 1.5495)
		Limit	39.157 (1.5416)

Model	Item	Unit: mm (in)	
2.5 L	Intake	STD	39.485 — 39.585 (1.5545 — 1.5585)
		Limit	39.385 (1.5506)
	Exhaust	STD	39.257 — 39.357 (1.5455 — 1.5495)
		Limit	39.157 (1.5416)

Cam base circle diameter A:

IN: 34.00 mm (1.3386 in)

EX: 34.00 mm (1.3386 in)

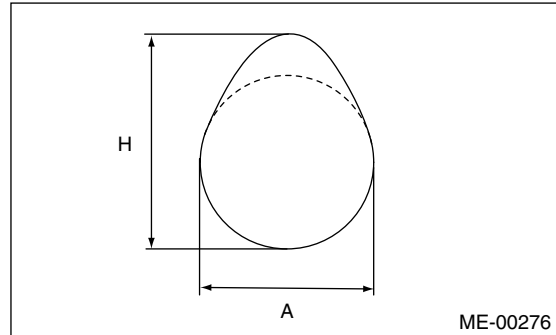

2. CAMSHAFT SUPPORT

Measure the thrust clearance of camshaft with dial gauge. If the clearance exceeds the limit, replace the camshaft support.

Standard:

0.030 — 0.090 mm (0.0012 — 0.0035 in)

Limit:

0.10 mm (0.0039 in)

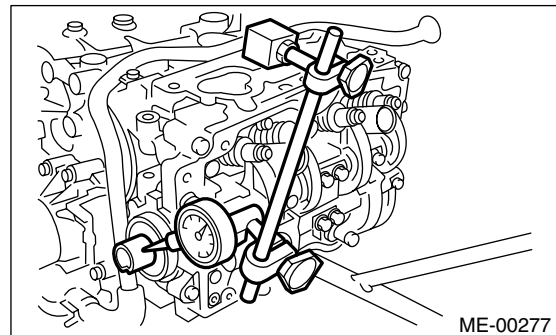

20. Cylinder Head Assembly

A: REMOVAL

- 1) Remove the V-belt. <Ref. to ME(H4SO)-43, REMOVAL, V-belt.>
- 2) Remove the crankshaft pulley. <Ref. to ME(H4SO)-45, REMOVAL, Crankshaft Pulley.>
- 3) Remove the timing belt cover. <Ref. to ME(H4SO)-47, REMOVAL, Timing Belt Cover.>
- 4) Remove the timing belt assembly. <Ref. to ME(H4SO)-48, REMOVAL, Timing Belt Assembly.>
- 5) Remove the camshaft sprocket. <Ref. to ME(H4SO)-53, REMOVAL, Camshaft Sprocket.>
- 6) Remove the intake manifold. <Ref. to FU(H4SO)-16, REMOVAL, Intake Manifold.> or <Ref. to FU(H4SOw/oOBD)-16, REMOVAL, Intake Manifold.>
- 7) Remove the bolt which installs the A/C compressor bracket on cylinder head.
- 8) Remove the valve rocker assembly. <Ref. to ME(H4SO)-56, REMOVAL, Valve Rocker Assembly.>
- 9) Remove the camshaft. <Ref. to ME(H4SO)-58, REMOVAL, Camshaft.>
- 10) Remove the cylinder head bolts in alphabetical sequence shown in the figure.

NOTE:

Leave the bolts (a) and (c) engaged by three or four threads to prevent cylinder head from falling.

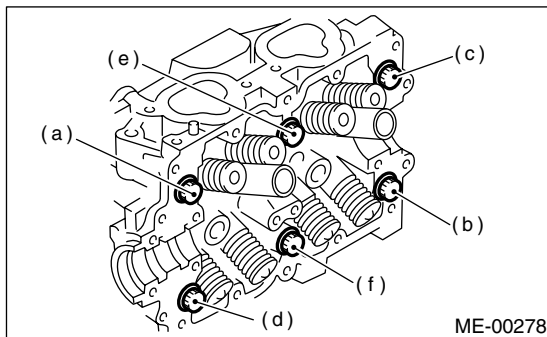

- 11) While tapping the cylinder head with a plastic hammer, separate it from cylinder block.
- 12) Remove the bolts (a) and (c) to remove cylinder head.

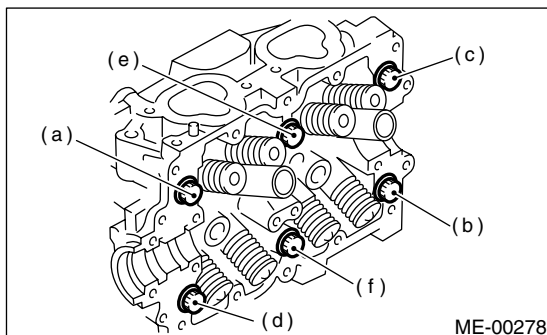

- 13) Remove the cylinder head gasket.

CAUTION:

Do not scratch the mating surface of cylinder head and cylinder block.

- 14) Similarly, remove the right side cylinder head.

B: INSTALLATION

- 1) Install the cylinder head and gaskets on cylinder block.

CAUTION:

- Use new cylinder head gaskets.
- Be careful not to scratch the mating surface of cylinder block and cylinder head.

- 2) Tighten the cylinder head bolts.
 - (1) Apply a coat of engine oil to the washers and bolt threads.
 - (2) Tighten all bolts to 29 N·m (3.0 kgf·m, 22 ft·lb) in alphabetical sequence. Then tighten all bolts to 69 N·m (7.0 kgf·m, 51 ft·lb) in alphabetical sequence.
 - (3) Back off all bolts by 180° first; back them off by 180° again in reverse order of installation.
 - (4) Tighten the bolts (a) and (b) to 34 N·m (3.5 kgf·m, 25 ft·lb) in reverse order of installation.
 - (5) Tighten the bolts (c), (d), (e) and (f) to 15 N·m (1.5 kgf·m, 11 ft·lb).
 - (6) Tighten all bolts by 80° to 90° in alphabetical sequence.

CAUTION:

Do not tighten bolts more than 90°.

- (7) Further tighten all bolts by 80° to 90° in alphabetical sequence shown in figure below.

CAUTION:

Ensure that the total “re-tightening angle” [in the former two steps], do not exceed 180°.

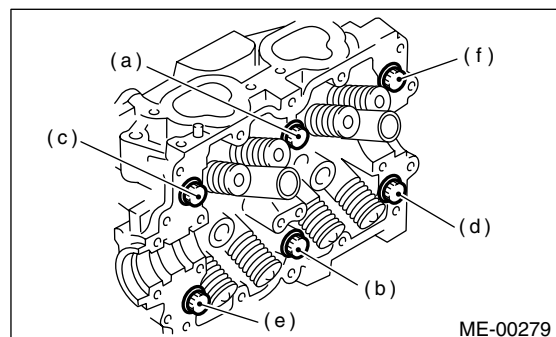

- 3) Install the camshaft. <Ref. to ME(H4SO)-59, INSTALLATION, Camshaft.>
- 4) Install the valve rocker assembly. <Ref. to ME(H4SO)-56, INSTALLATION, Valve Rocker Assembly.>
- 5) Install the A/C compressor bracket on cylinder head.

Cylinder Head Assembly

MECHANICAL

6) Install the intake manifold. <Ref. to FU(H4SO)-18, INSTALLATION, Intake Manifold.> or <Ref. to FU(H4SOw/oOBD)-18, INSTALLATION, Intake Manifold.>

7) Install the camshaft sprocket. <Ref. to ME(H4SO)-53, INSTALLATION, Camshaft Sprocket.>

8) Install the timing belt assembly. <Ref. to ME(H4SO)-49, INSTALLATION, Timing Belt Assembly.>

9) Install the timing belt cover. <Ref. to ME(H4SO)-47, INSTALLATION, Timing Belt Cover.>

10) Install the crankshaft pulley. <Ref. to ME(H4SO)-45, INSTALLATION, Crankshaft Pulley.>

11) Install the V-belt. <Ref. to ME(H4SO)-43, INSTALLATION, V-belt.>

2) Set the ST on valve spring. Compress the valve spring, and then remove the valve spring retainer key. Remove each valve and valve spring.

ST 499718000 VALVE SPRING REMOVER

CAUTION:

- Mark each valve to prevent confusion.
- Use extreme care not to damage the lips of intake valve oil seals and exhaust valve oil seals.

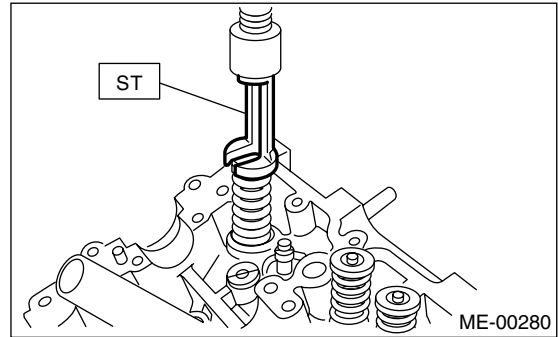

C: DISASSEMBLY

1) Place the cylinder head on ST.

ST 498267800 CYLINDER HEAD TABLE

D: ASSEMBLY

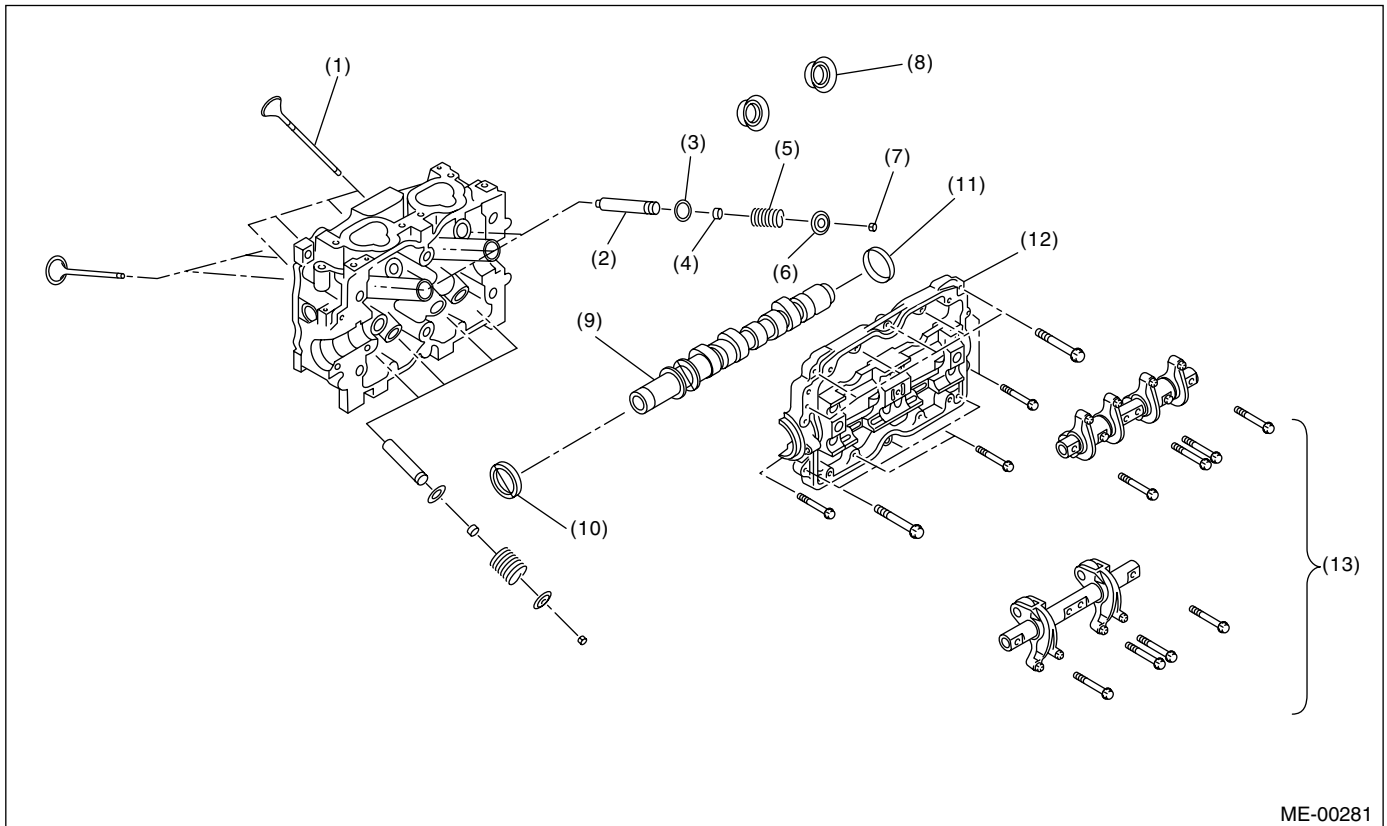

- | | | |
|-----------------------|-----------------------|------------------------|
| (1) Valve | (6) Retainer | (11) Plug |
| (2) Valve guide | (7) Retainer key | (12) Camshaft cap |
| (3) Valve spring seat | (8) Spark plug gasket | (13) Valve rocker ASSY |
| (4) Oil seal | (9) Camshaft | |
| (5) Valve spring | (10) Oil seal | |

Cylinder Head Assembly

MECHANICAL

1) Installation of valve spring and valve

(1) Place the cylinder head on ST.

ST 498267800 CYLINDER HEAD TABLE

(2) Coat the stem of each valve with engine oil and insert valve into valve guide.

NOTE:

When inserting the valve into valve guide, use special care not to damage the oil seal lip.

(3) Install the valve spring and retainer.

NOTE:

Be sure to install the valve springs with their close-coiled end facing the seat on the cylinder head.

(4) Set the ST on valve spring.

ST 499718000 VALVE SPRING REMOVER

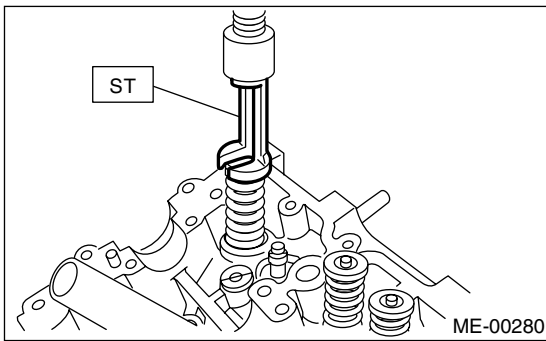

(5) Compress the valve spring, and then fit the valve spring retainer key.

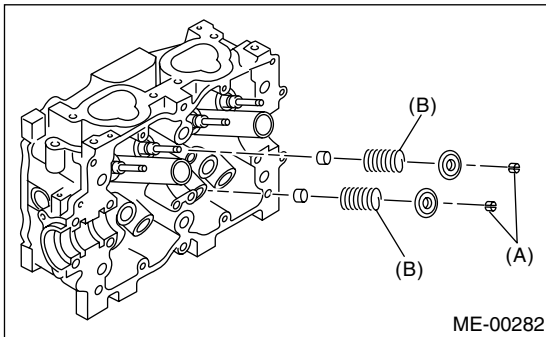

(A) Retainer key

(B) Valve spring

(6) After installing, tap the valve spring retainers lightly with plastic hammer for better seating.

E: INSPECTION

1. VALVE SPRING

1) Check the valve springs for damage, free length, and tension. Replace the valve spring if it is not to the specifications presented below.

2) To measure the squareness of valve spring, stand the spring on a surface plate and measure its deflection at the top using a try square.

Free length	54.30 mm (2.1378 in)
Squareness	2.5°, 2.4 mm (0.094 in)
Tension/spring height	Set 214 — 246 N (22 — 25 kgf, 48 — 55 lb)/ 45.0 mm (1.772 in)
	Lift 526 — 582 N (54 — 59 kgf, 119 — 130 lb)/ 34.7 mm (1.366 in)

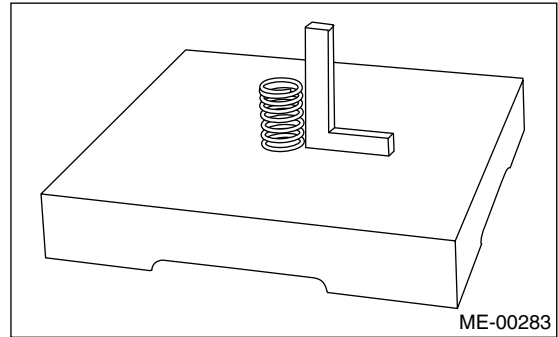

2. INTAKE AND EXHAUST VALVE OIL SEAL

Replace the oil seal with new one, if lip is damaged or spring out of place, or when the surfaces of intake valve and valve seat are reconditioned or intake valve guide is replaced. Use pliers to pinch and remove oil seal from valve.

1) Place the cylinder head on ST1.

2) Press-fit oil seal using ST2.

CAUTION:

- Apply engine oil to oil seal before press-fitting.
- When press-fitting oil seal, do not use hammer or strike in.
- Differentiate between intake valve oil seal and exhaust valve oil seal by noting their difference in color.

ST1 498267800 CYLINDER HEAD TABLE

ST2 498857100 VALVE OIL SEAL GUIDE

Color of rubber part:

Intake [Black]

Exhaust [Brown]

Color of spring part:

Intake [Silver]

Exhaust [Silver]

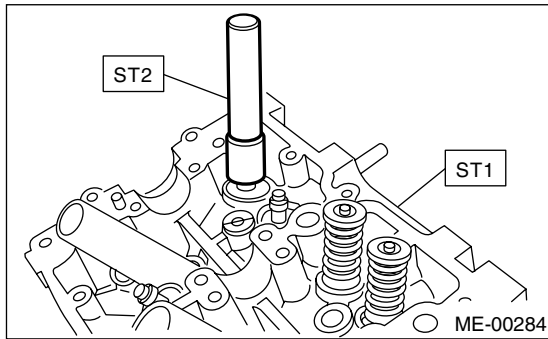

F: ADJUSTMENT

1. CYLINDER HEAD

1) Make sure that no crack or other damage exists. In addition to visual inspection, inspect important areas by means of red lead check.

Also make sure that gasket installing surface shows no trace of gas and water leaks.

2) Place the cylinder head on ST.

ST 498267800 CYLINDER HEAD TABLE

3) Measure the warping of the cylinder head surface that mates with crankcase using a straight edge and thickness gauge.

If the warping exceeds 0.05 mm (0.0020 in), re-grind the surface with a surface grinder.

Warping limit:

0.05 mm (0.0020 in)

Grinding limit:

0.1 mm (0.004 in)

Standard height of cylinder head:

97.5 mm (3.839 in)

NOTE:

Uneven torque for the cylinder head bolts can cause warping. When reassembling, pay special attention to the torque so as to tighten evenly.

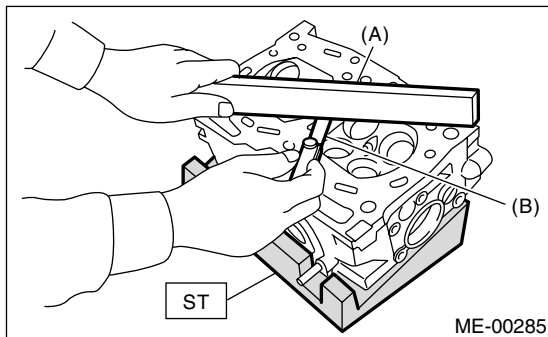

(A) Straight edge

(B) Thickness gauge

2. VALVE SEAT

Inspect the intake and exhaust valve seats, and then correct the contact surfaces with valve seat cutter if they are defective or when valve guides are replaced.

Valve seat width: *W*

Intake (A)

Standard 1.0 mm (0.039 in)

Limit 1.7 mm (0.067 in)

Exhaust (B)

Standard 1.5 mm (0.059 in)

Limit 2.2 mm (0.087 in)

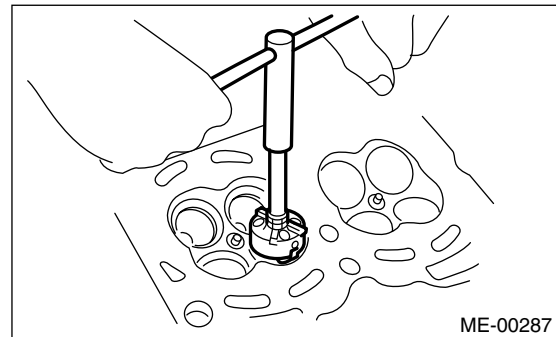
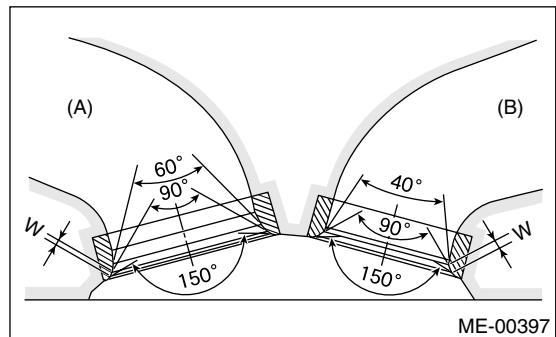

3. VALVE GUIDE

1) Check the clearance between valve guide and stem. The clearance can be checked by measuring the outside diameter of valve stem and the inside diameter of valve guide with outside and inside micrometers respectively.

Clearance between the valve guide and valve stem:

Standard

Intake 0.035 — 0.062 mm (0.0014 — 0.0024 in)

Exhaust 0.040 — 0.067 mm (0.0016 — 0.0026 in)

Cylinder Head Assembly

MECHANICAL

Limit

0.15 mm (0.0059 in)

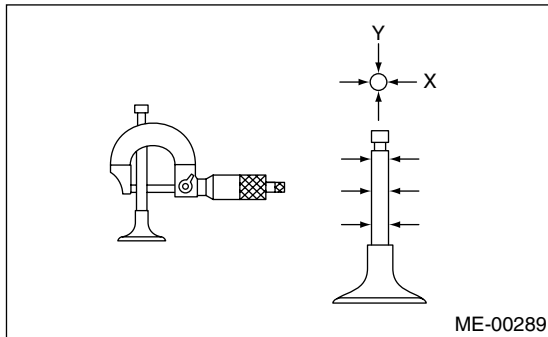
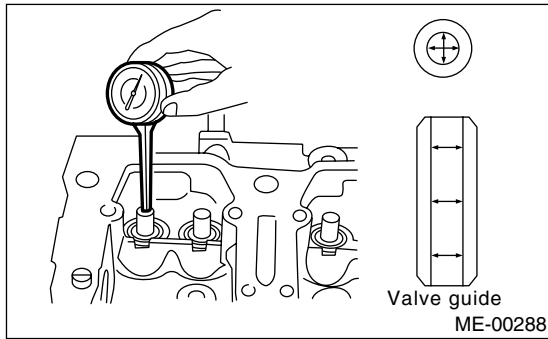

2) If the clearance between valve guide and stem exceeds the limit, replace the valve guide or valve itself whichever shows greater amount of wear. See the following procedure for valve guide replacement.

Valve guide inner diameter:

6.000 — 6.012 mm (0.2362 — 0.2367 in)

Valve stem outer diameters:

Intake

5.950 — 5.965 mm (0.2343 — 0.2348 in)

Exhaust

5.945 — 5.960 mm (0.2341 — 0.2346 in)

(1) Place the cylinder head on ST1 with the combustion chamber upward so that valve guides enter the holes in ST1.

(2) Insert the ST2 into valve guide and press it down to remove valve guide.

ST1 498267800 CYLINDER HEAD TABLE
ST2 499767200 VALVE GUIDE REMOVER

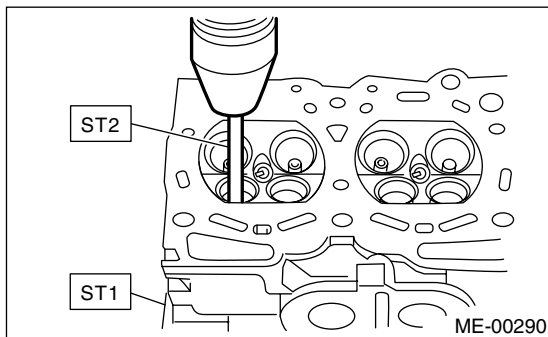

(3) Turn the cylinder head upside down and place ST as shown in the figure.

Intake side:

ST 499767700 VALVE GUIDE ADJUSTER

Exhaust side:

ST 499767800 VALVE GUIDE ADJUSTER

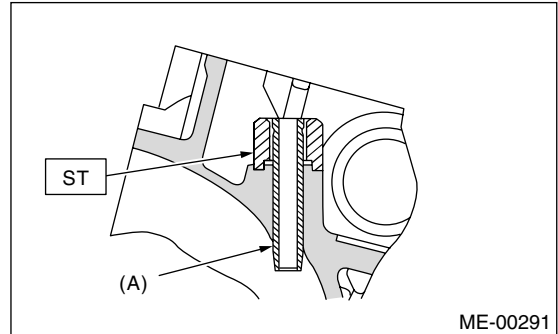

(A) Valve guide

(4) Before installing new oversize valve guide, make sure that neither scratches nor damages exist on the inside surface of valve guide holes in cylinder head.

(5) Put new valve guide, coated with sufficient oil, in the cylinder, and then insert the ST1 into valve guide. Press in until the valve guide upper end is flush with the upper surface of ST2.

ST1 499767200 VALVE GUIDE REMOVER

Intake side:

ST2 499767700 VALVE GUIDE ADJUSTER

Exhaust side:

ST2 499767800 VALVE GUIDE ADJUSTER

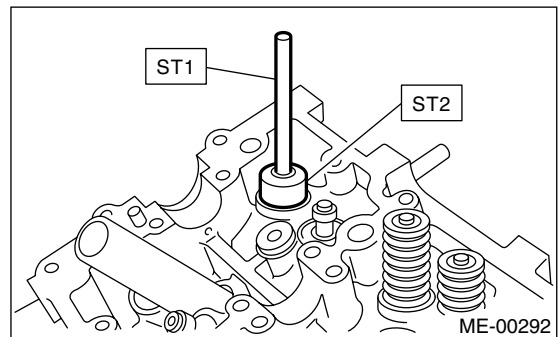

(6) Check the valve guide protrusion.

Valve guide protrusion: L

Intake

20.0 — 20.5 mm (0.787 — 0.807 in)

Exhaust

16.5 — 17.0 mm (0.650 — 0.669 in)

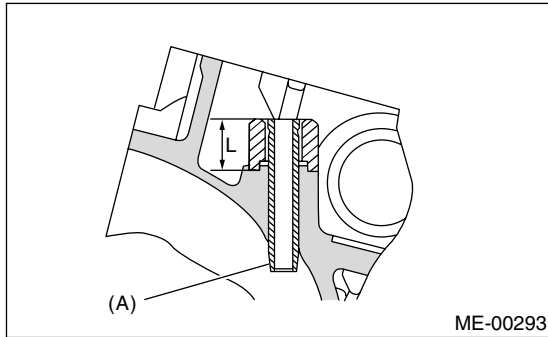

(A) Valve guide

(7) Ream the inside of valve guide with ST. Gently rotate the reamer clockwise while pressing it lightly into valve guide, and return it also rotating clockwise. After reaming, clean the valve guide to remove chips.

CAUTION:

- Apply engine oil to the reamer when reaming.
- If the inner surface of the valve guide is torn, the edge of the reamer should be slightly ground with an oil stone.
- If the inner surface of the valve guide becomes lustrous and the reamer does not chips, use a new reamer or remedy the reamer.

ST 499767400 VALVE GUIDE REAMER

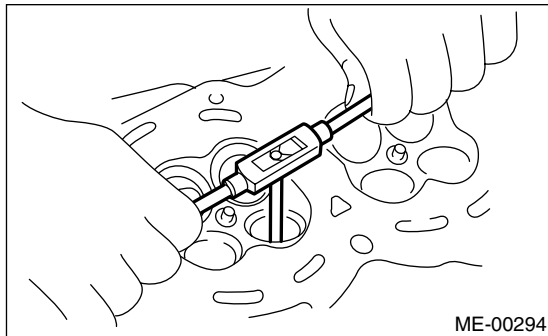

(8) Recheck the contact condition between valve and valve seat after replacing valve guide.

4. INTAKE AND EXHAUST VALVE

1) Inspect the flange and stem of valve, and replace if damaged, worn, or deformed, or if “H” is less than the specified limit.

H:

Intake

Standard 1.0 mm (0.039 in)

Limit 0.6 mm (0.024 in)

Exhaust

Standard 1.2 mm (0.047 in)

Limit 0.6 mm (0.024 in)

Valve overall length:

Intake

120.6 mm (4.75 in)

Exhaust

121.7 mm (4.79 in)

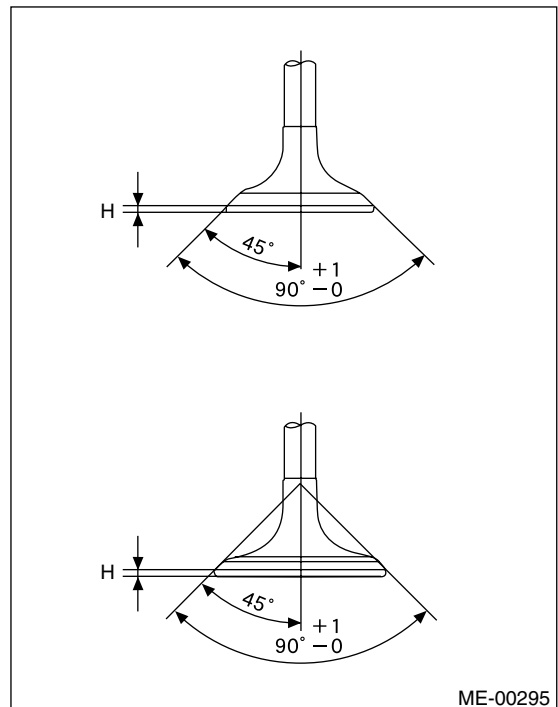

2) Put a small amount of grinding compound on the seat surface and lap the valve and seat surface. <Ref. to ME(H4SO)-65, VALVE SEAT, ADJUSTMENT, Cylinder Head Assembly.> Install a new intake valve oil seal after lapping.

Cylinder Block

MECHANICAL

21. Cylinder Block

A: REMOVAL

NOTE:

Before conducting this procedure, drain the engine oil completely if applicable.

1) Remove the intake manifold. <Ref. to FU(H4SO)-16, REMOVAL, Intake Manifold.> or <Ref. to FU(H4SOw/oOBD)-16, REMOVAL, Intake Manifold.>

2) Remove the V-belt. <Ref. to ME(H4SO)-43, REMOVAL, V-belt.>

3) Remove the crankshaft pulley. <Ref. to ME(H4SO)-45, REMOVAL, Crankshaft Pulley.>

4) Remove the timing belt cover. <Ref. to ME(H4SO)-47, REMOVAL, Timing Belt Cover.>

5) Remove the timing belt assembly. <Ref. to ME(H4SO)-48, REMOVAL, Timing Belt Assembly.>

6) Remove the camshaft sprocket. <Ref. to ME(H4SO)-53, REMOVAL, Camshaft Sprocket.>

7) Remove the crankshaft sprocket. <Ref. to ME(H4SO)-45, REMOVAL, Crankshaft Pulley.>

8) Remove the generator and A/C compressor with their brackets.

9) Remove the rocker cover.

10) Remove the cylinder head bolts in alphabetical sequence shown in the figure.

NOTE:

Leave bolts (a) and (c) engaged by three or four threads to prevent cylinder head from falling.

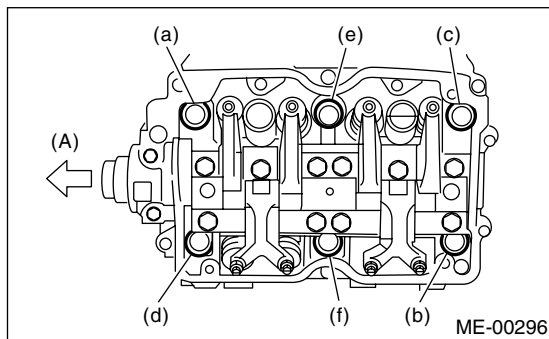

(A) Front

11) While tapping the cylinder head with a plastic hammer, separate it from cylinder block.

12) Remove the bolts (a) and (c) to remove cylinder head.

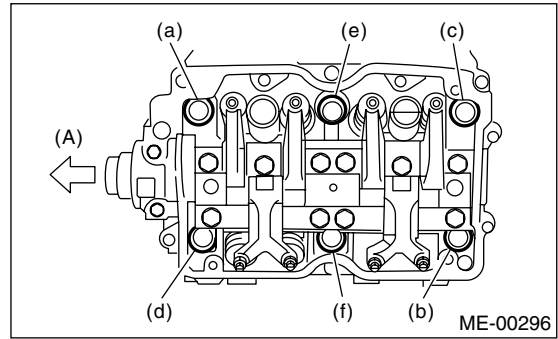

(A) Front

13) Remove the cylinder head gasket.

NOTE:

Do not scratch the mating surface of cylinder head and cylinder block.

14) Similarly, remove the right side cylinder head.

15) Remove the clutch housing cover. (MT model)

16) Remove the flywheel (MT model) or drive plate (AT model).

Using the ST, lock the crankshaft.

ST 498497100 CRANKSHAFT STOPPER

• MT MODEL

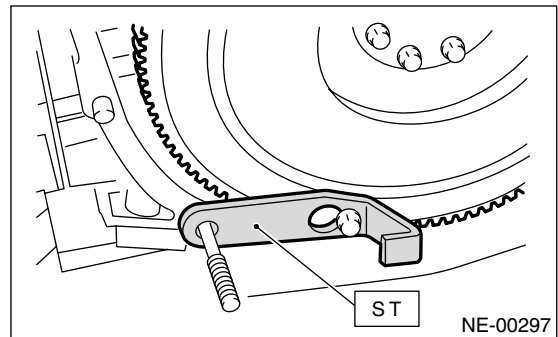

• AT MODEL

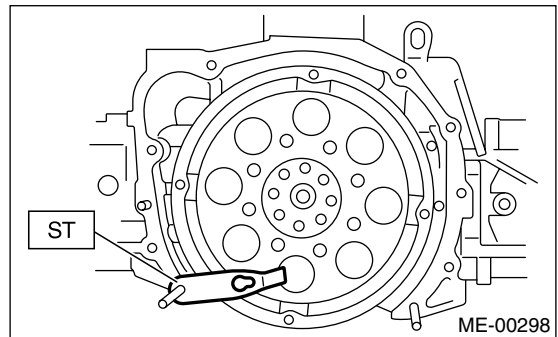

NOTE:

Using STs, remove the flywheel. (2.5 L MT model)

Cylinder Block

MECHANICAL

ST1 498497100 CRANKSHAFT STOPPER
ST2 499057000 TORX® PLUS

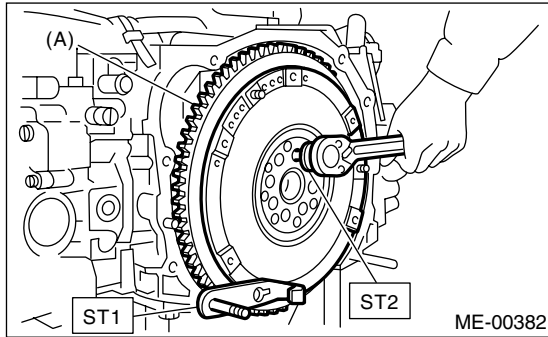

(A) Flywheel

- 17) Remove the oil separator cover.
- 18) Remove the water by-pass pipe for heater.
- 19) Loosen the bolts in alphabetical sequence as shown in the figure, and then remove the water pump.

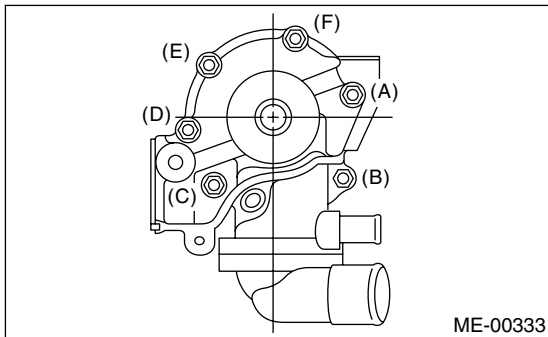

- 20) Remove the oil pump from cylinder block. Use a flat-bladed screwdriver as shown in the figure when removing oil pump.

CAUTION:

Be careful not to scratch the mating surface of cylinder block and oil pump.

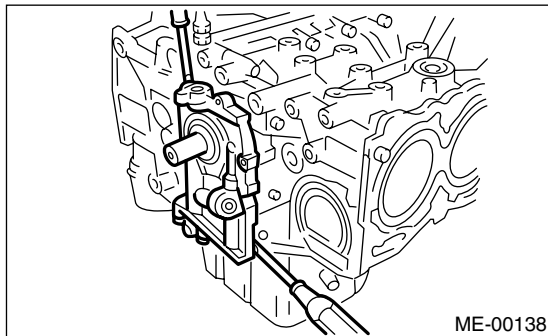

21) Removal of oil pan

- (1) Turn the cylinder block to face the #2 and #4 piston sides upward.
- (2) Remove the bolts which secure the oil pan to cylinder block.

- (3) Insert a oil pan cutter blade between cylinder block-to-oil pan clearance, and then remove the oil pan.

NOTE:

Do not use a screwdriver or similar tool in place of oil pan cutter.

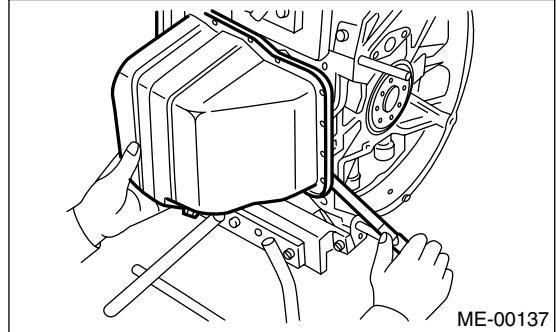

- 22) Remove the oil strainer stay.
 - 23) Remove the oil strainer.
 - 24) Remove the baffle plate.
 - 25) Remove the oil filter using ST.
- ST 498547000 OIL FILTER WRENCH

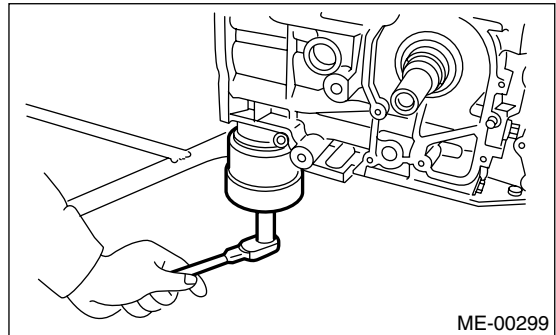

- 26) Remove the water pipe.

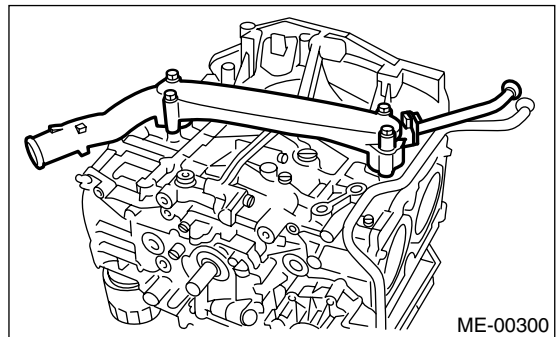

Cylinder Block

MECHANICAL

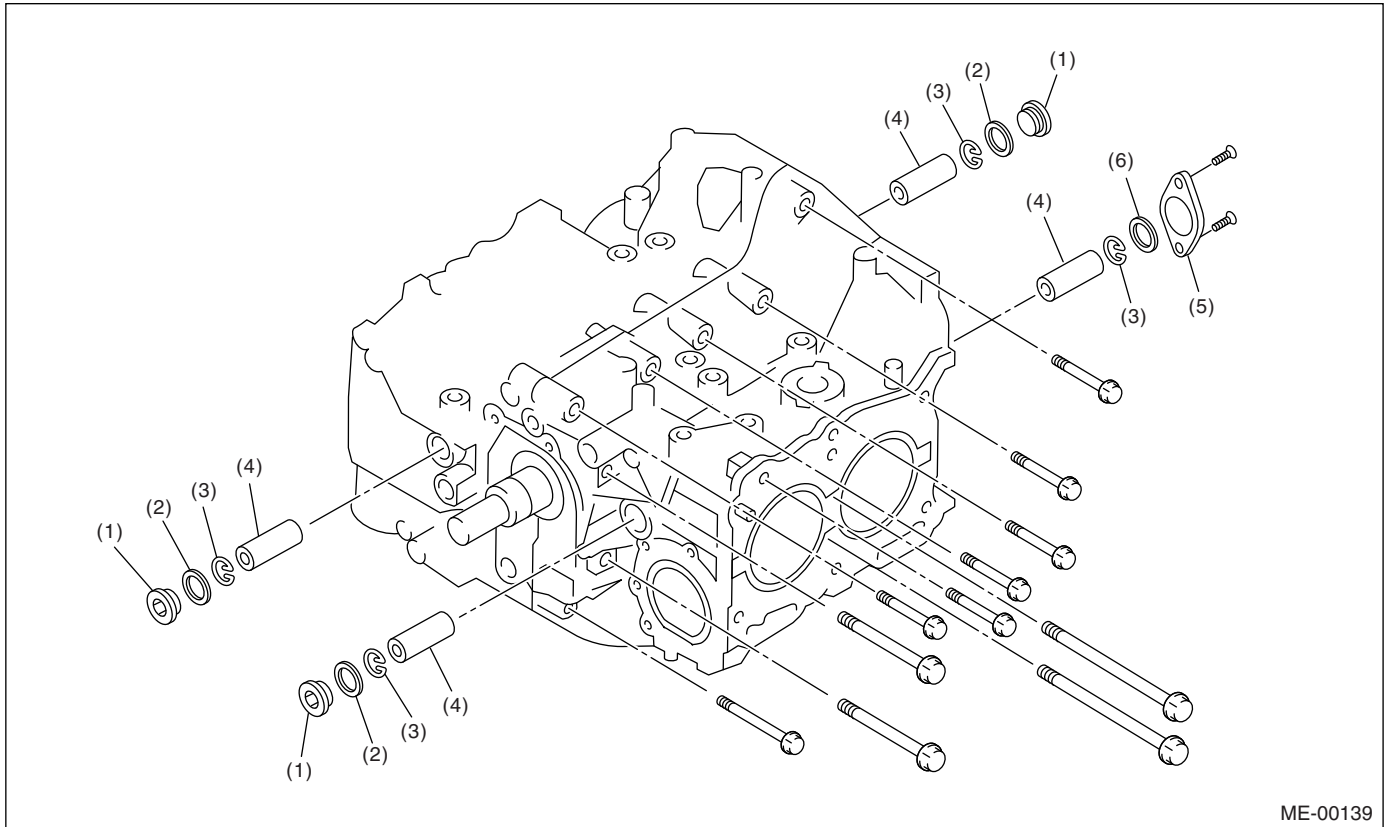

ME-00139

- | | | |
|-----------------------|----------------|------------------------|
| (1) Service hole plug | (3) Circlip | (5) Service hole cover |
| (2) Gasket | (4) Piston pin | (6) O-ring |

27) Remove the service hole cover and service hole plugs using hexagon wrench [14 mm (0.55 in)].

ST 499897200 PISTON CIRCLIP PLIER

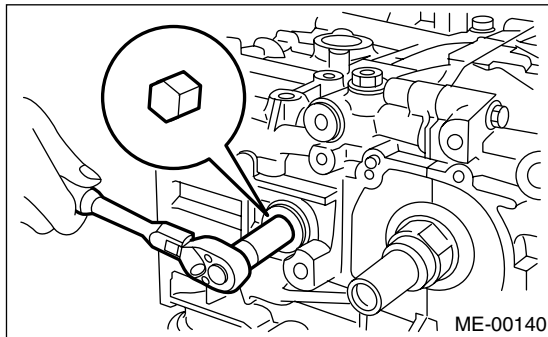

ME-00140

28) Rotate the crankshaft to bring #1 and #2 pistons to bottom dead center position, and then remove the piston circlip through service hole of #1 and #2 cylinders.

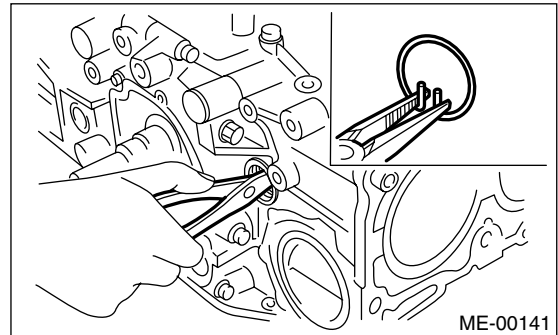

ME-00141

29) Draw out the piston pin from #1 and #2 pistons using ST.

ST 499097700 PISTON PIN REMOVER

NOTE:

Be careful not to confuse the original combination of piston, piston pin and cylinder.

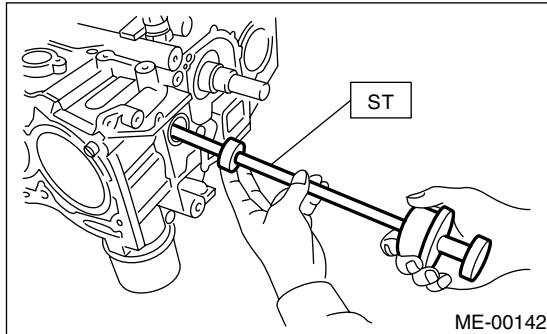

30) Similarly remove the piston pins from #3 and #4 pistons.

31) Remove the bolts which connect the cylinder block on the side of #2 and #4 cylinders.

32) Back off the bolts which connect the cylinder block on the side of #1 and #3 cylinders two or three turns.

33) Set up the cylinder block so that #1 and #3 cylinders are on the upper side, and then remove the cylinder block connecting bolts.

34) Separate the cylinder blocks (RH) and (LH).

Cylinder Block

MECHANICAL

NOTE:

When separating the cylinder block, do not allow the connecting rod to fall and damage the cylinder block.

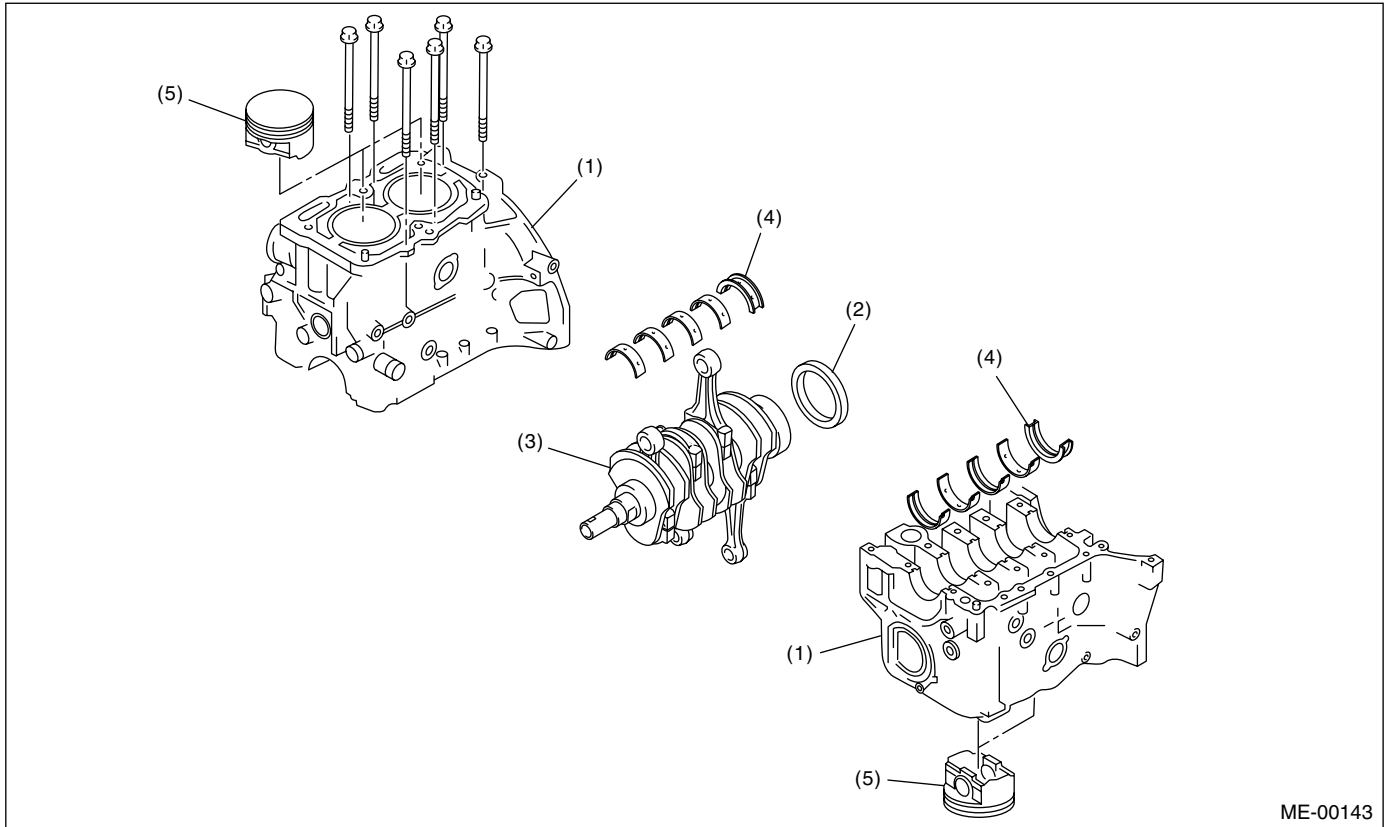

ME-00143

(1) Cylinder block

(3) Crankshaft

(5) Piston

(2) Rear oil seal

(4) Crankshaft bearing

35) Remove the rear oil seal.

36) Remove the crankshaft together with connecting rod.

37) Remove the crankshaft bearings from cylinder block using hammer handle.

NOTE:

Do not confuse the combination of crankshaft bearings. Press bearing at the end opposite to locking lip.

38) Draw out each piston from cylinder block using wooden bar or hammer handle.

NOTE:

Do not confuse the combination of piston and cylinder.

B: INSTALLATION

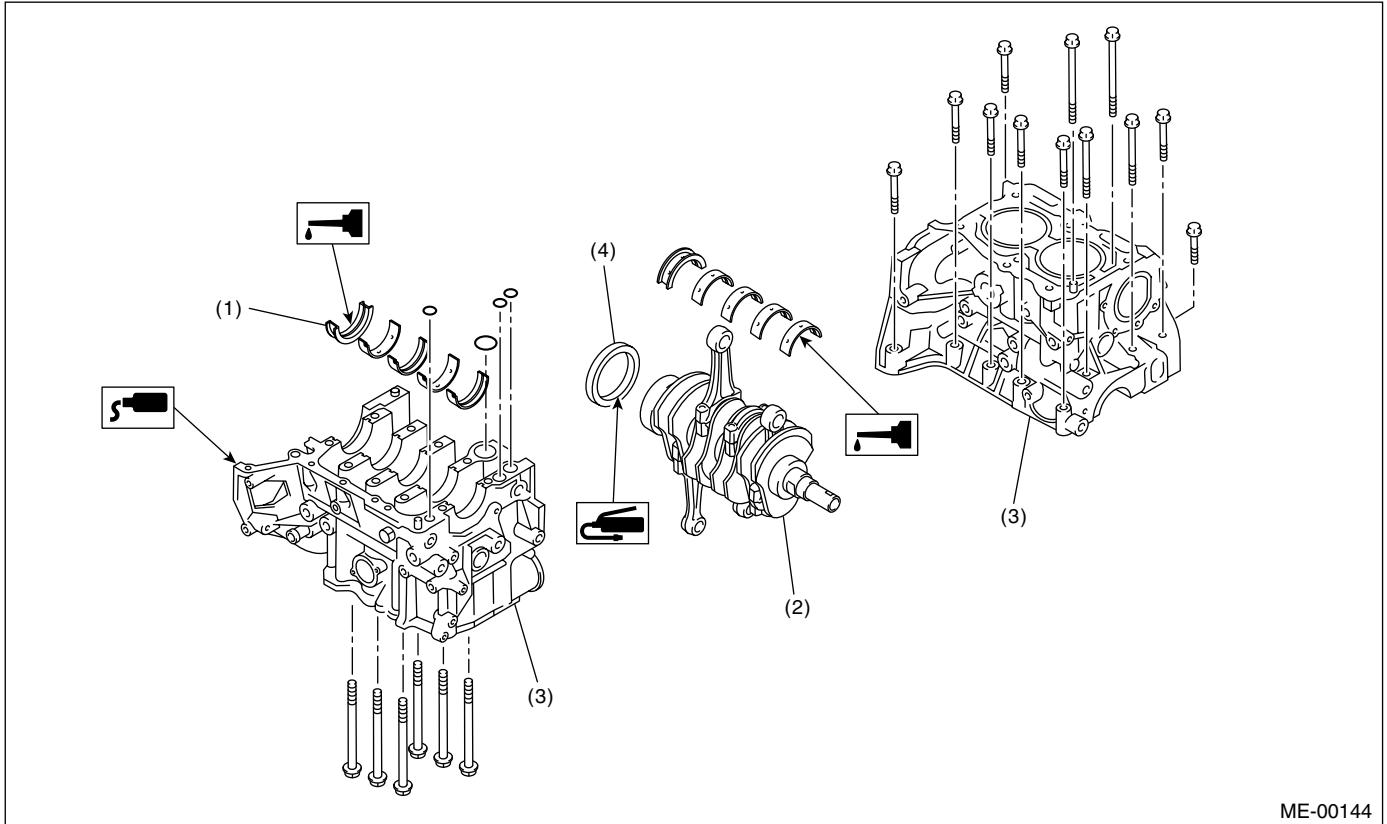

ME-00144

- (1) Crankshaft bearing
- (2) Crankshaft

- (3) Cylinder block

- (4) Rear oil seal

NOTE:

Remove oil in the mating surface of bearing and cylinder block before installation. Also apply a coat of engine oil to crankshaft pins.

1) Position the crankshaft on #2 and #4 cylinder block.

2) Apply fluid packing to the mating surface of #1 and #3 cylinder block, and position it on #2 and #4 cylinder block.

Fluid packing:

Part No. 004403007

THREE BOND 1215 or equivalent

NOTE:

Do not allow fluid packing to jut into O-ring grooves, oil passages, bearing grooves, etc.

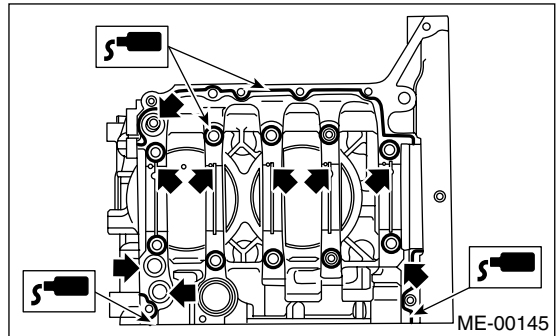

3) Tighten the 10 mm cylinder block connecting bolts in alphabetical sequence shown in the figure. (LH side)

Cylinder Block

MECHANICAL

Tightening torque:
15 N·m (1.5 kgf-m, 10.8 ft-lb)

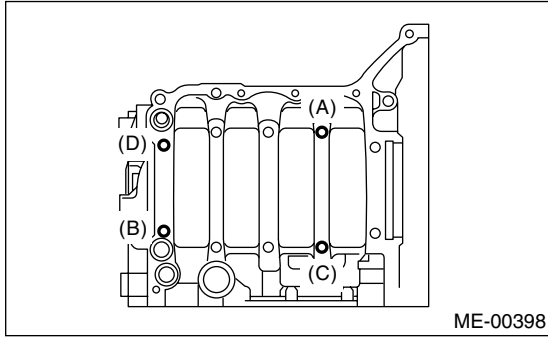

4) Tighten the 10 mm cylinder block connecting bolts in alphabetical sequence shown in the figure. (RH side)

Tightening torque:
15 N·m (1.5 kgf-m, 10.8 ft-lb)

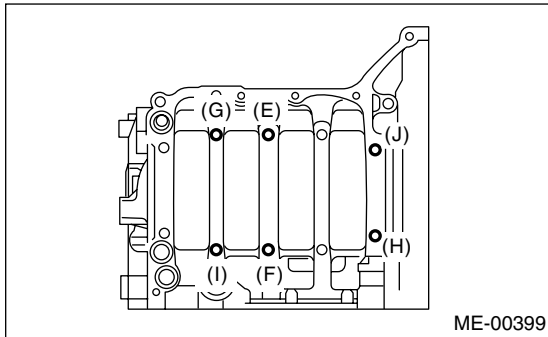

5) Further tighten the LH side bolts (A — D) to 90° in alphabetical sequence.

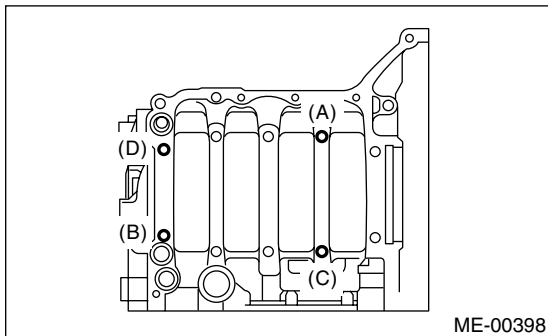

6) Further tighten the RH side bolts (E — J) to 90° in alphabetical sequence.

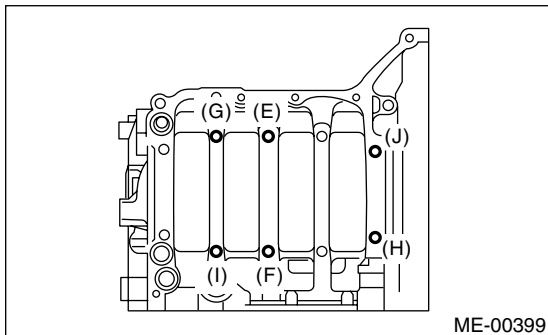

7) Tighten the 8 mm and 6 mm cylinder block connecting bolts in alphabetical sequence shown in the figure.

Tightening torque:
(A) — (G): 25 N·m (2.5 kgf-m, 18.1 ft-lb)
(H): 6.4 N·m (0.65 kgf-m, 4.7 ft-lb)

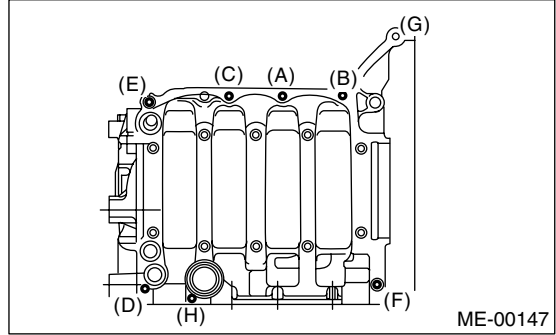

8) Install the rear oil seal using ST1 and ST2.
 ST1 499597100 OIL SEAL GUIDE
 ST2 499587200 OIL SEAL INSTALLER

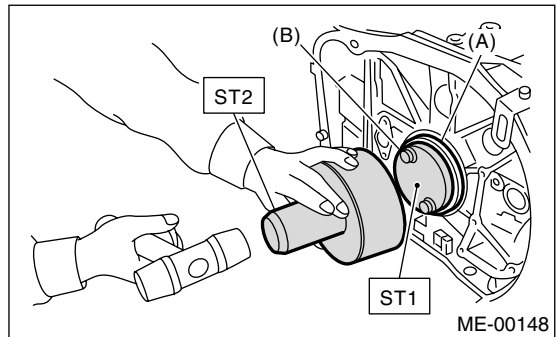

(A) Rear oil seal
 (B) Flywheel attaching bolt

9) Position the top ring gap at (A) or (B) in the figure.

10) Position the second ring gap at 180° on the reverse side for top ring gap.

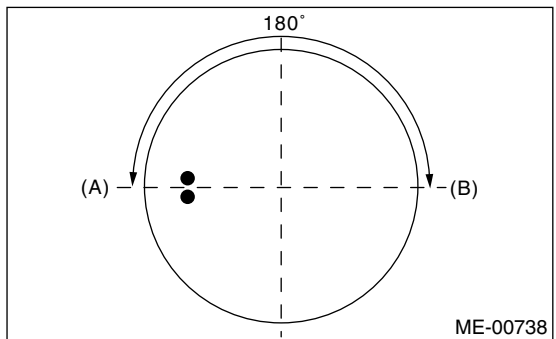

Cylinder Block

MECHANICAL

11) Position the expander gap at (C) in the figure.

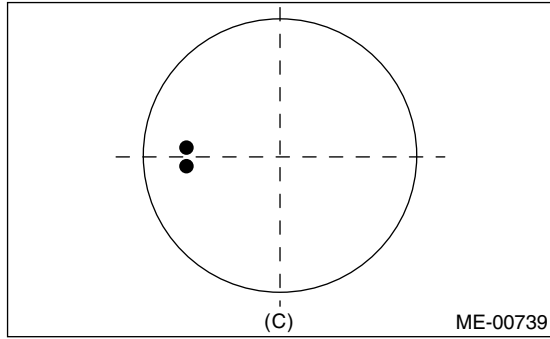

12) Position the lower rail gap at (D) in the figure.

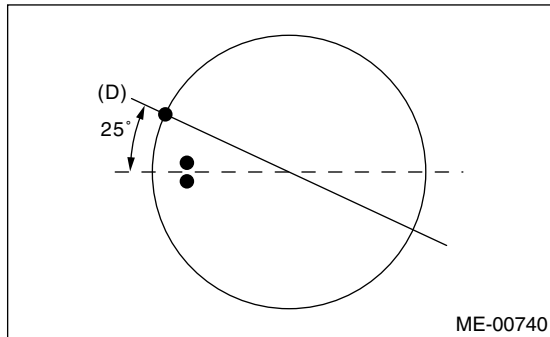

NOTE:

Align the lower rail stopper (F) to the lateral hole (E) on the piston.

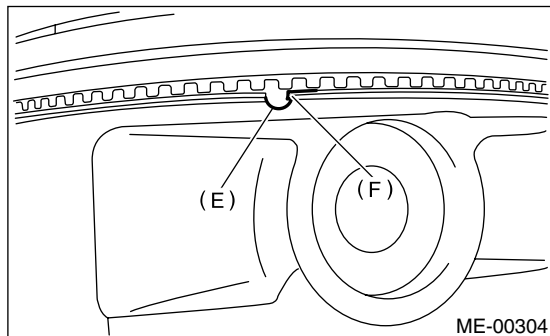

13) Position the upper rail gap at (G) in the figure.

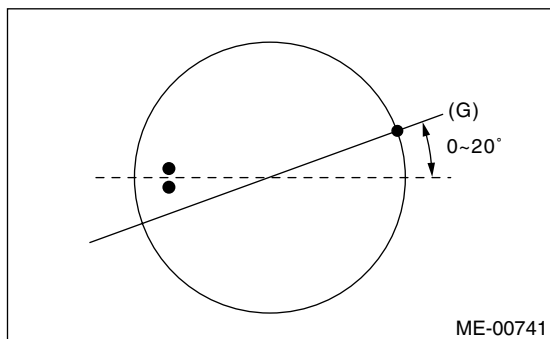

CAUTION:

• Ensure ring gaps do not face the same direction.

• Ensure ring gaps are not within the piston skirt area.

14) Install the circlip.

Install circlips in the piston holes located opposite service holes in cylinder block, when positioning all pistons in the corresponding cylinders.

NOTE:

Use new circlips.

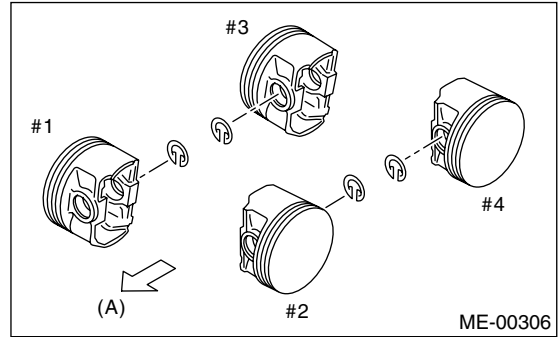

(A) Front side

CAUTION:

Piston front mark faces towards the front of the engine.

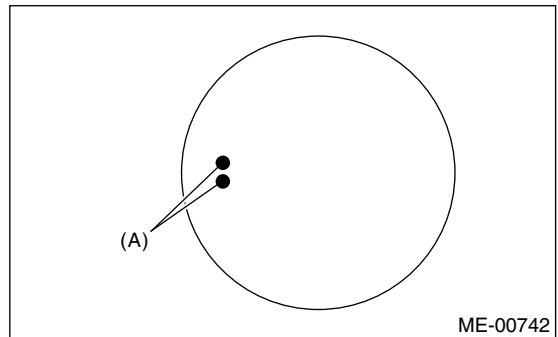

(A) Front mark

Cylinder Block

MECHANICAL

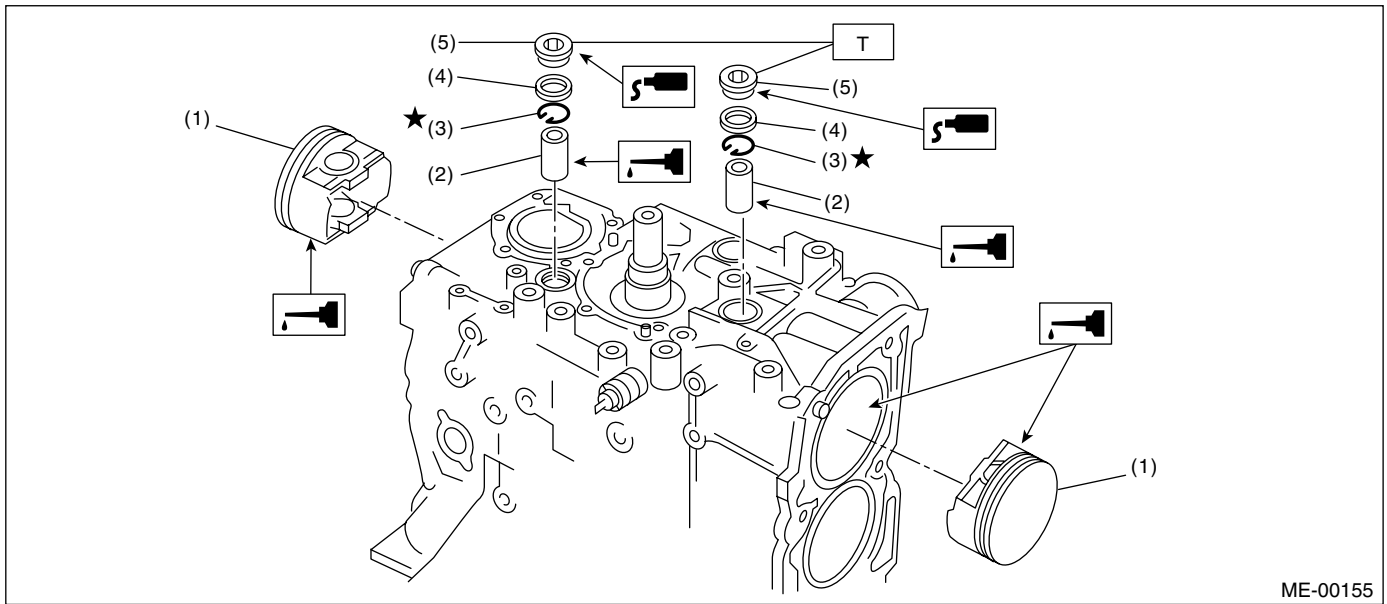

- | | |
|----------------|-----------------------|
| (1) Piston | (4) Gasket |
| (2) Piston pin | (5) Service hole plug |
| (3) Circlip | |

Tightening torque: N-m (kgf-m, ft-lb)
T: 70 (7.0, 50.6)

15) Installing piston

- (1) Turn the cylinder block to face the #1 and #2 piston side upward.
- (2) Using the ST1, turn the crankshaft so that #1 and #2 connecting rods are set at bottom dead center.

ST1 499987500 CRANKSHAFT SOCKET

- (3) Apply a coat of engine oil to pistons and cylinders, and then insert the pistons in their cylinders using ST2.

ST2 498747000 PISTON GUIDE (1.6 L model)

ST2 398744300 PISTON GUIDE (2.0 L model)

ST2 498747300 PISTON GUIDE (2.5 L model)

ST3 499017100 PISTON PIN GUIDE

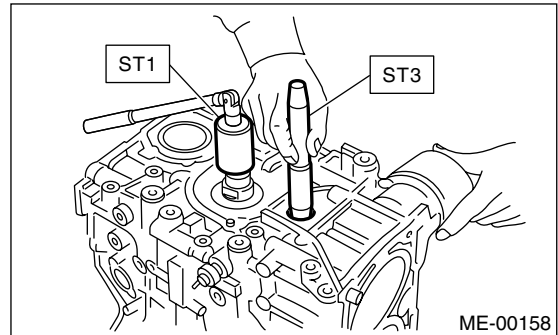

- (3) Apply a coat of engine oil to the piston pin, and then insert the piston pin into piston and connecting rod through service hole.
- (4) Install the circlip.

NOTE:

Use new circlips.

ST3 499897200 PISTON CIRCLIP PLIER

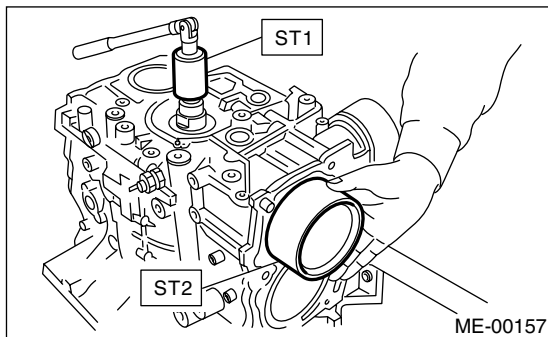

16) Installing piston pin

- (1) Apply a coat of engine oil to the ST3 before insertion.
- (2) Insert the ST3 into service hole to align piston pin hole with connecting rod small end.

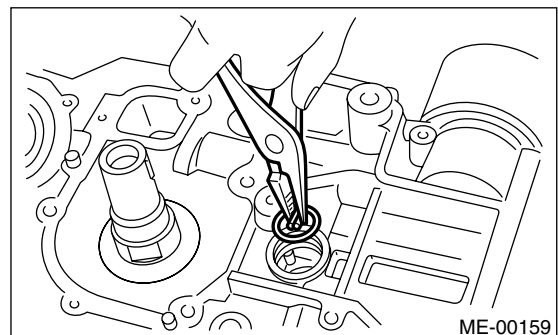

- (5) Apply fluid packing around the service hole plug.

Cylinder Block

MECHANICAL

Fluid packing:

Part No. 004403007

THREE BOND 1215 or equivalent

(6) Install the service hole plug and gasket.

NOTE:

Use a new gasket.

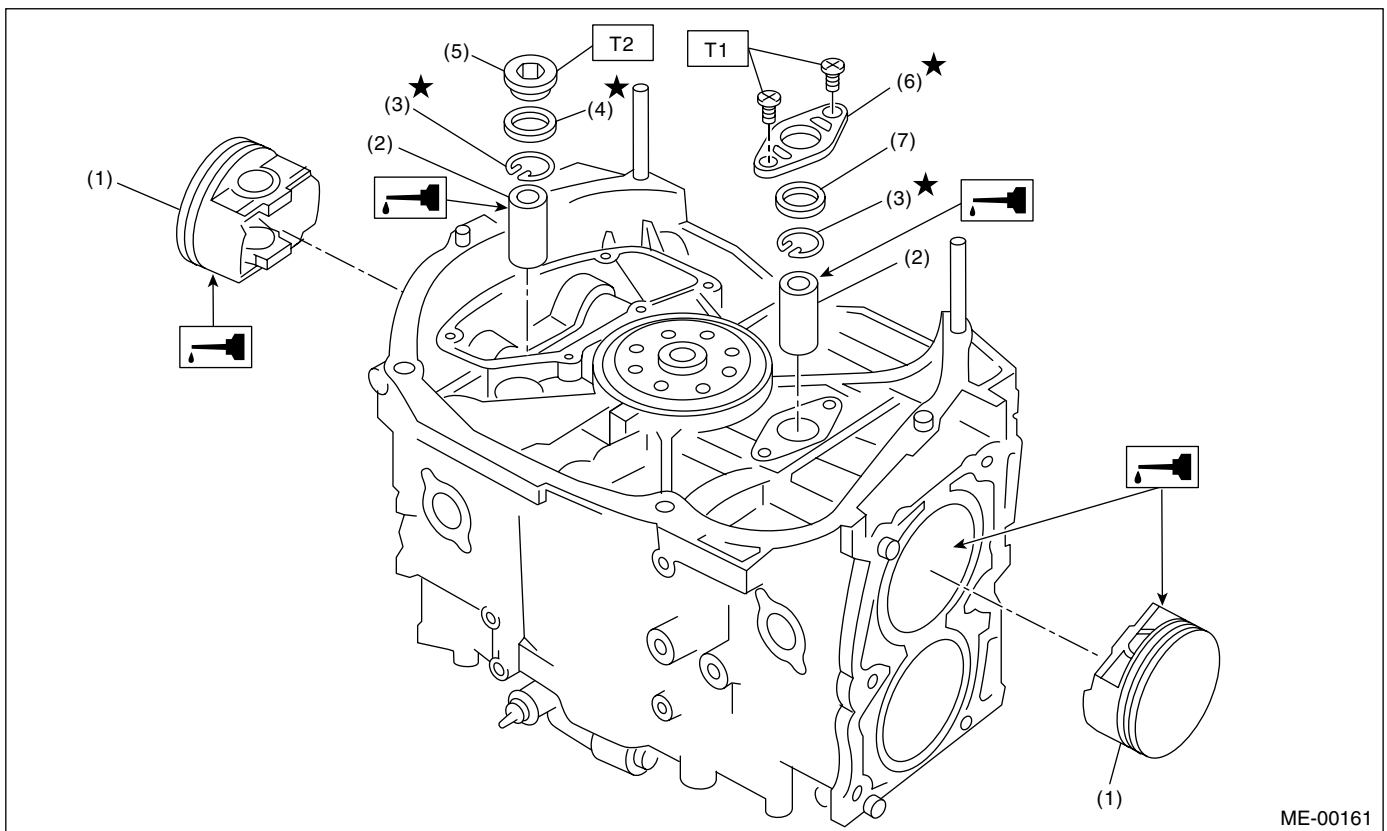
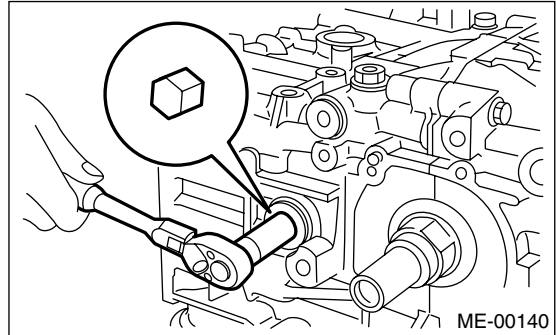
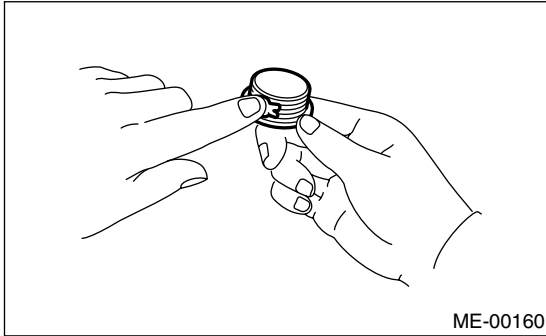

- | | |
|----------------|------------------------|
| (1) Piston | (5) Service hole plug |
| (2) Piston pin | (6) Service hole cover |
| (3) Circlip | (7) O-ring |
| (4) Gasket | |

Tightening torque: N-m (kgf-m, ft-lb)

T1: 6.4 (0.65, 4.7)

T2: 70 (7.1, 51.4)

(7) Turn the cylinder block to face the #3 and #4 piston side upward. Using the same procedures as used for #1 and #2 cylinders, install the pistons and piston pins.

Cylinder Block

MECHANICAL

17) Install the water pipe.

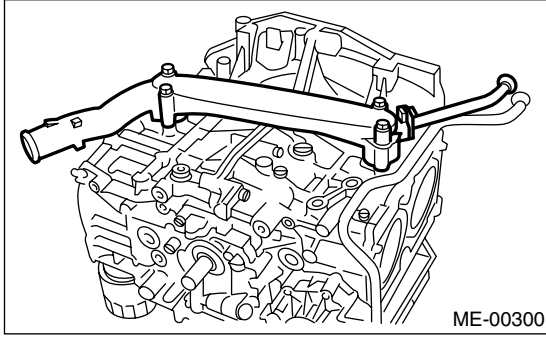

18) Install the baffle plate.

Tightening torque:

6.4 N·m (0.65 kgf·m, 4.7 ft·lb)

19) Install the oil strainer and O-ring.

Tightening torque:

10 N·m (1.0 kgf·m, 7 ft·lb)

20) Install the oil strainer stay.

21) Apply fluid packing to the matching surfaces, and then install the oil pan.

Fluid packing:

Part No. 004403007

THREE BOND 1215 or equivalent

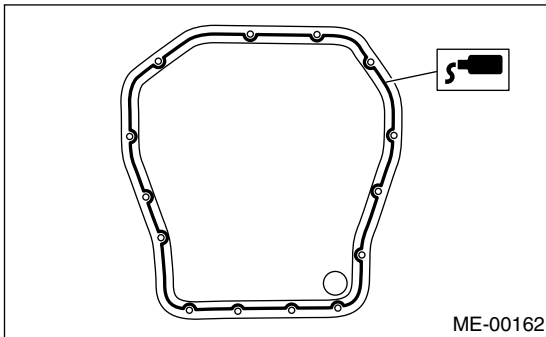

22) Apply fluid packing to the matching surfaces, and then install the oil separator cover.

Fluid packing:

Part No. 004403007

THREE BOND 1215 or equivalent

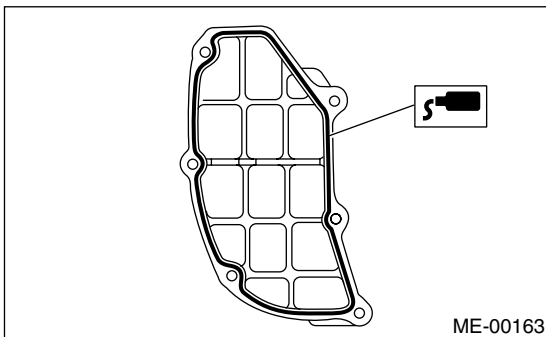

23) Install the flywheel or drive plate.

To lock the crankshaft, use ST.

ST 498497100 CRANKSHAFT STOPPER

Tightening torque:

72 N·m (7.3 kgf·m, 52.8 ft·lb)

• MT MODEL

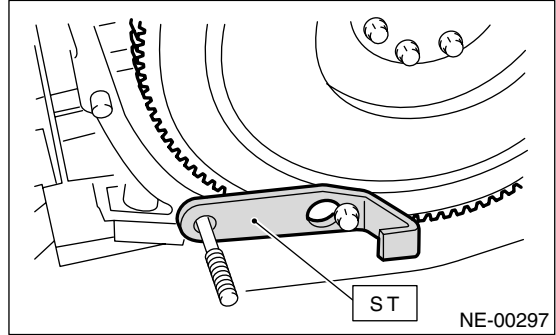

• AT MODEL

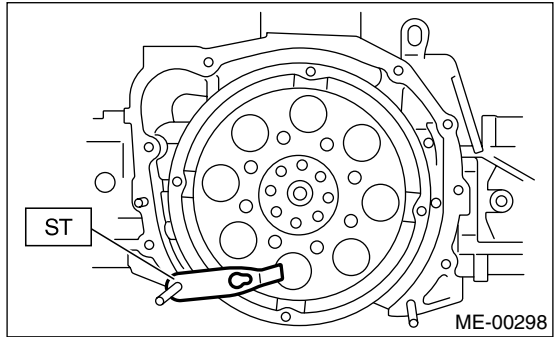

NOTE:

Using STs, remove the flywheel. (2.5 L MT model)

ST1 498497100 CRANKSHAFT STOPPER

ST2 499057000 TORX® PLUS

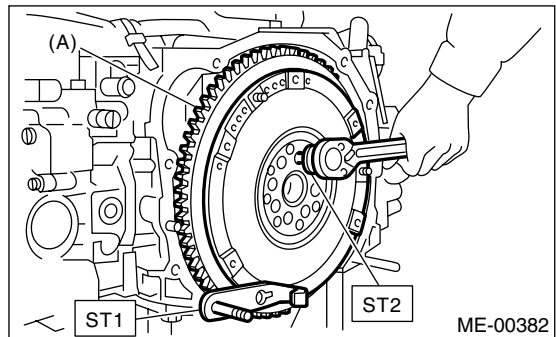

(A) Flywheel

24) Install the housing cover.

25) Installation of oil pump

(1) Discard the front oil seal after removal. Replace with a new one using the ST.

ST 499587100 OIL SEAL INSTALLER

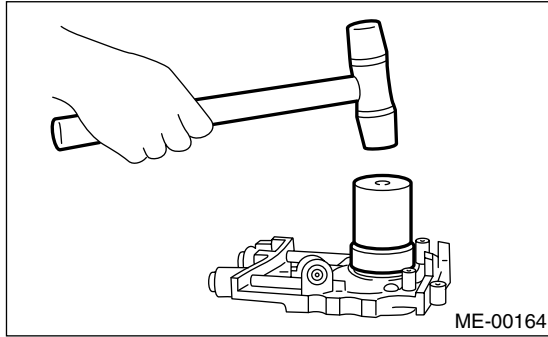

(2) Apply fluid packing to the matching surface of oil pump.

Fluid packing:

Part No. 004403007

THREE BOND 1215 or equivalent

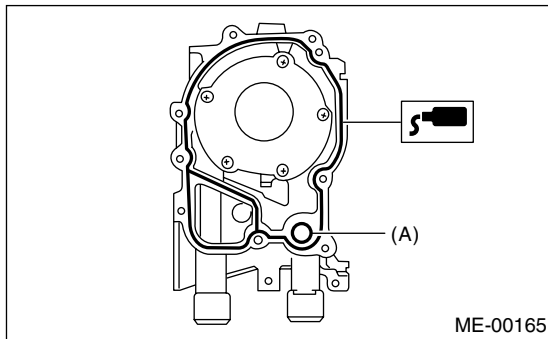

(A) O-ring

(3) Apply a coat of engine oil to the inside of oil seal.

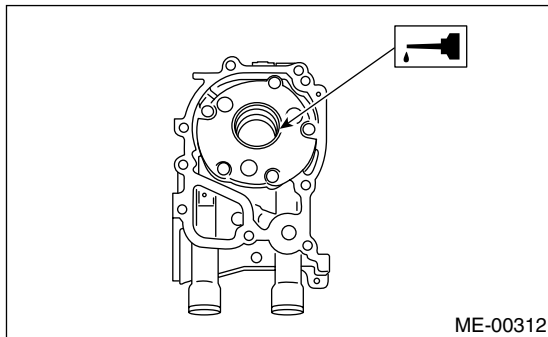

(4) Install the oil pump on cylinder block. Be careful not to damage the oil seal during installation.

Tightening torque:

6.4 N·m (0.65 kgf-m, 4.7 ft-lb)

CAUTION:

- Do not forget to install the O-ring and seal when installing oil pump.
- Align flat surface of oil pump's inner rotor with crankshaft before installation.

26) Install the water pump and gasket.

Tightening torque:

First; 12 N·m (1.2 kgf-m, 8.7 ft-lb)

Second; 12 N·m (1.2 kgf-m, 8.7 ft-lb)

CAUTION:

- Be sure to use a new gasket.
- When installing the water pump, tighten the bolts in two stages in alphabetical sequence as shown in the figure.

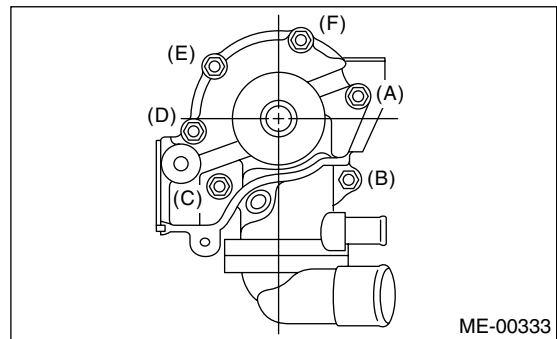

27) Install the water by-pass pipe for heater.

28) Install the oil filter using ST.

ST 498547000 OIL FILTER WRENCH

29) Tighten the cylinder head bolts.

(1) Apply a coat of engine oil to the washers and bolt threads.

(2) Tighten all bolts to 29 N·m (3.0 kgf-m, 22 ft-lb) in alphabetical sequence.

Then tighten all bolts to 69 N·m (7.0 kgf-m, 51 ft-lb) in alphabetical sequence.

(3) Back off all bolts by 180° first; back them off by 180° again.

(4) Tighten the bolts (A) and (B) to 34 N·m (3.5 kgf-m, 25 ft-lb).

(5) Tighten the bolts (C), (D), (E) and (F) to 15 N·m (1.5 kgf-m, 11 ft-lb).

(6) Tighten all bolts by 80° to 90° in alphabetical sequence.

CAUTION:

Do not tighten bolts more than 90°.

(7) Further tighten all bolts by 80° to 90° in alphabetical sequence.

Cylinder Block

MECHANICAL

CAUTION:
Ensure that the total “re-tightening angle” [in the former two steps], do not exceed 180°.

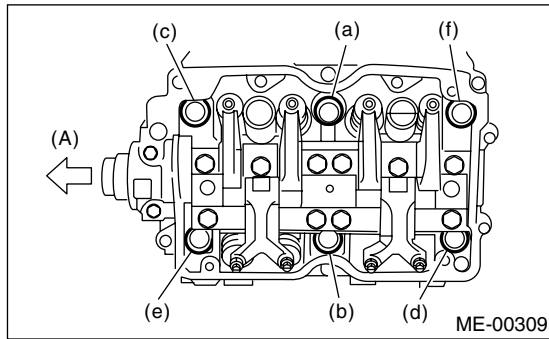

(A) Front

30) Install the oil level gauge guide, and then tighten the attaching bolt (left side only).

31) Install the rocker cover.

32) Install the crankshaft sprocket. <Ref. to ME(H4SO)-55, INSTALLATION, Crankshaft Sprocket.>

C: DISASSEMBLY

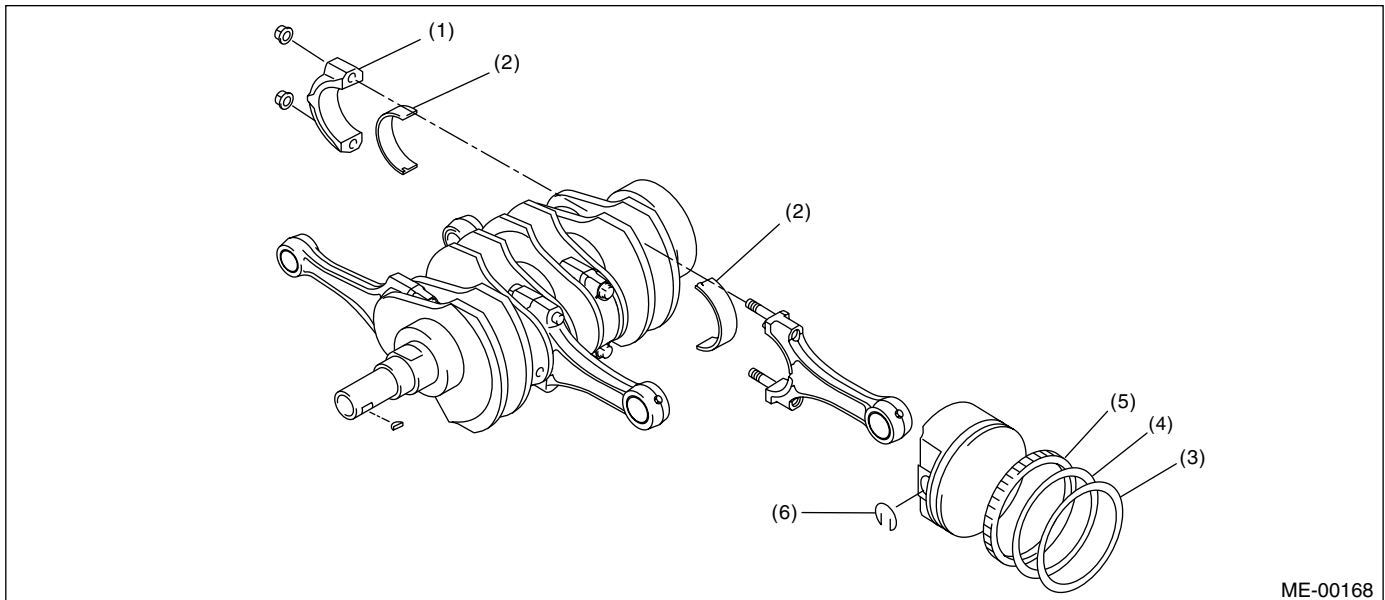

(1) Connecting rod cap

(2) Connecting rod bearing

(3) Top ring

(4) Second ring

(5) Oil ring

(6) Circlip

- 1) Remove the connecting rod cap.
- 2) Remove the connecting rod bearing.

NOTE:

Arrange the removed connecting rod, connecting rod cap and bearing in order to prevent confusion.

3) Remove the piston rings using the piston ring expander.

4) Remove the oil ring by hand.

NOTE:

Arrange the removed piston rings in good order to prevent confusion.

5) Remove the circlip.

D: ASSEMBLY

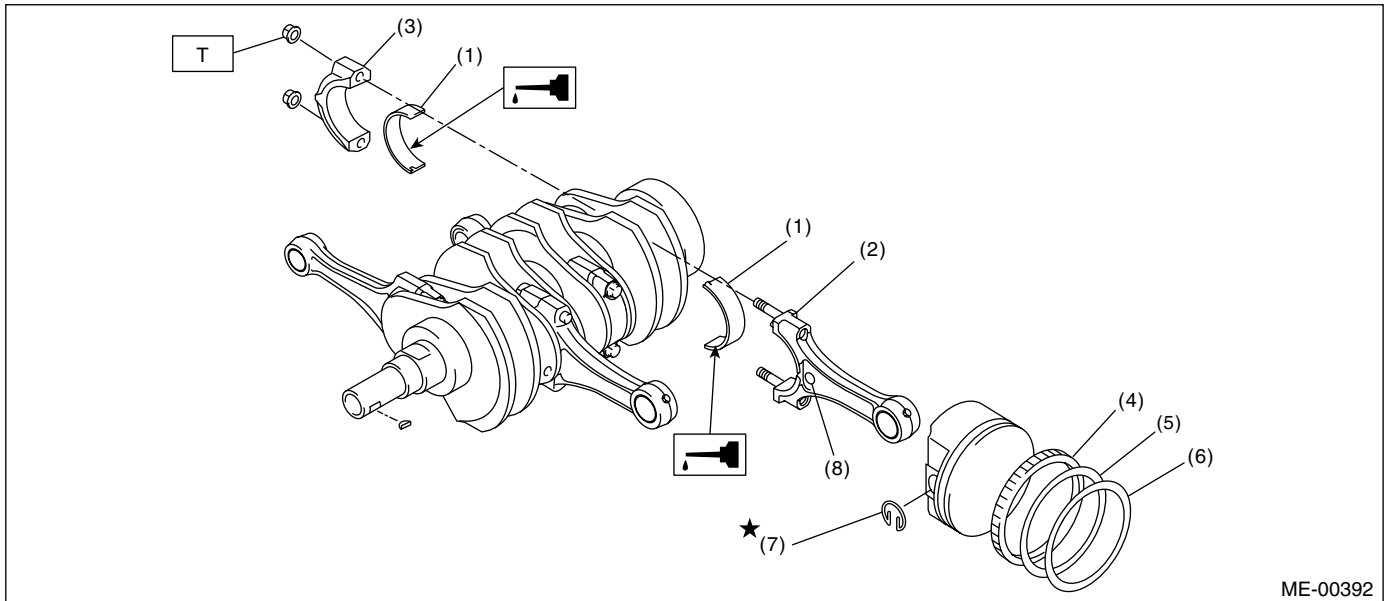

- | | |
|----------------------------|-----------------|
| (1) Connecting rod bearing | (5) Second ring |
| (2) Connecting rod | (6) Top ring |
| (3) Connecting rod cap | (7) Circlip |
| (4) Oil ring | (8) Side mark |

Tightening torque: N·m (kgf·m, ft·lb)

T: 45 (4.6, 33)

1) Apply oil to the surfaces of the connecting rod bearings.

2) Install the connecting rod bearings on connecting rods and connecting rod caps.

3) Position each connecting rod with the marked side facing forward, and then install them.

4) Install the connecting rod cap with connecting rod nut.

Ensure the arrow on connecting rod cap faces the front during installation.

CAUTION:

- Each connecting rod has its own mating cap. Make sure that they are assembled correctly by checking their matching number.
- When tightening the connecting rod nuts, apply oil on the threads.

5) Install the expander, lower rail and upper rail in this order by hand. Then install the second ring and top ring using piston ring expander.

E: INSPECTION

1. CYLINDER BLOCK

1) Visually check for cracks and damage. Especially, inspect the important parts by means of red lead check.

2) Check the oil passages for clogging.

3) Inspect the crankcase surface that mates with cylinder head for warping by using a straight edge, and correct by grinding if necessary.

Warping limit:

0.05 mm (0.0020 in)

Grinding limit:

0.1 mm (0.004 in)

Standard height of cylinder block:

201.0 mm (7.91 in)

2. CYLINDER AND PISTON

1) The cylinder bore size is stamped on cylinder block's front upper surface.

NOTE:

- Measurement should be performed at a temperature 20°C (68°F).
- Standard sized pistons are classified into two grades, "A" and "B". These grades should be used as a guide line in selecting a standard piston.

Cylinder Block

MECHANICAL

Standard diameter:

1.6 L model

A: 87.905 — 87.915 mm (3.4608 — 3.4612 in)

B: 87.895 — 87.905 mm (3.4604 — 3.4608 in)

2.0 L model

A: 92.005 — 92.015 mm (3.6222 — 3.6226 in)

B: 91.995 — 92.005 mm (3.6218 — 3.6222 in)

2.5 L model

A: 99.505 — 99.515 mm (3.9175 — 3.9179 in)

B: 99.495 — 99.505 mm (3.9171 — 3.9175 in)

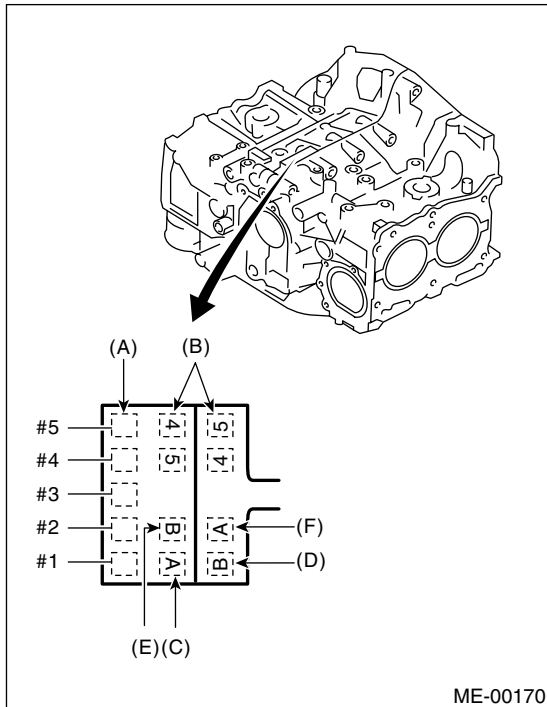

- (A) Main journal size mark
- (B) Cylinder block RH-LH combination mark
- (C) #1 cylinder bore size mark
- (D) #2 cylinder bore size mark
- (E) #3 cylinder bore size mark
- (F) #4 cylinder bore size mark

2) How to measure the inner diameter of each cylinder

Measure the inner diameter of each cylinder in both the thrust and piston pin directions at the heights shown in the figure, using a cylinder bore gauge.

NOTE:

Measurement should be performed at a temperature 20°C (68°F).

Taper:

Standard

0.015 mm (0.0006 in)

Limit

0.050 mm (0.0020 in)

Out-of-roundness:

Standard

0.010 mm (0.0004 in)

Limit

0.050 mm (0.0020 in)

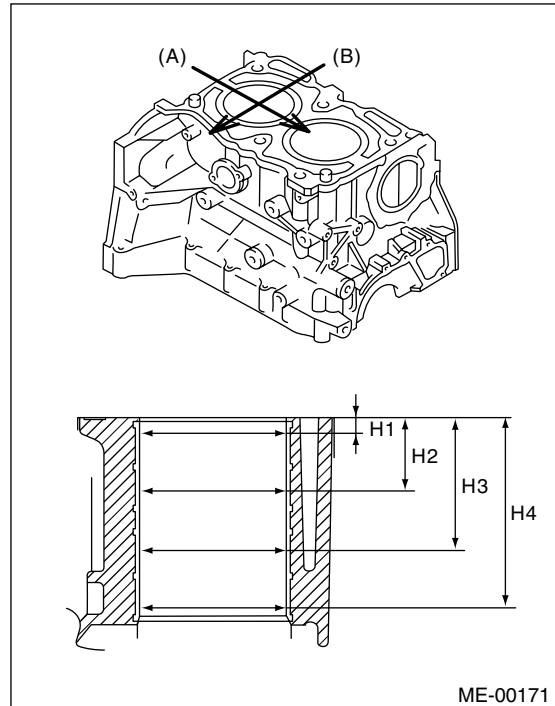

- (A) Piston pin direction
- (B) Thrust direction
- H1 10 mm (0.39 in)
- H2 45 mm (1.77 in)
- H3 80 mm (3.15 in)
- H4 115 mm (4.35 in)

3) When the piston is to be replaced due to general or cylinder wear, determine a suitable sized piston by measuring the piston clearance.

4) How to measure the outer diameter of each piston

Measure the outer diameter of each piston at the height shown in the figure. (Thrust direction)

NOTE:

Measurement should be performed at a temperature of 20°C (68°F).

Piston grade point H:

1.6 L and 2.0 L model

40.0 mm (1.575 in)

2.5 L model

37.0 mm (1.457 in)

Piston outer diameter:

1.6 L model

Standard

A: 87.885 — 87.895 mm (3.4600 — 3.4604 in)

B: 87.875 — 87.885 mm (3.4596 — 3.4699 in)

0.25 mm (0.0098 in) oversize

88.125 — 88.135 mm (3.4695 — 3.4699 in)

0.50 mm (0.0197 in) oversize

88.375 — 88.385 mm (3.4793 — 3.4797 in)

2.0 L model

Standard

A: 91.985 — 91.995 mm (3.6214 — 3.6218 in)

B: 91.975 — 91.985 mm (3.6211 — 3.6214 in)

0.25 mm (0.0098 in) oversize

92.225 — 92.235 mm (3.6309 — 3.6313 in)

0.50 mm (0.0197 in) oversize

92.475 — 92.485 mm (3.6407 — 3.6411 in)

2.5 L model

Standard

A: 99.485 — 99.495 mm (3.9167 — 3.9171 in)

B: 99.475 — 99.485 mm (3.9163 — 3.9167 in)

0.25 mm (0.0098 in) oversize

99.725 — 99.735 mm (3.9262 — 3.9266 in)

0.50 mm (0.0197 in) oversize

99.975 — 99.985 mm (3.9360 — 3.9364 in)

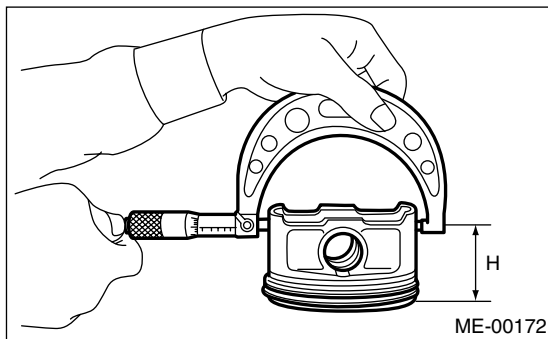

5) Calculate the clearance between cylinder and piston.

NOTE:

Measurement should be performed at a temperature of 20°C (68°F).

Cylinder to piston clearance at 20°C (68°F):

Standard

0.010 — 0.030 mm (0.0004 — 0.0012 in)

Limit

0.050 mm (0.0020 in)

6) Boring and honing

(1) If the value of taper, out-of-roundness, or cylinder-to-piston clearance measured exceeds the specified limit or if there is any damage on the cylinder wall, reboring it to use an oversize piston.

CAUTION:

When any of the cylinders needs reboring, all other cylinders must be bored at the same time, and use oversize pistons. Do not perform boring on one cylinder only, nor use an oversize piston for one cylinder only.

(2) If the cylinder inner diameter exceeds the limit after boring and honing, replace the crankcase.

NOTE:

Immediately after reboring, the cylinder diameter may differ from its real diameter due to temperature rise. Thus, pay attention to this when measuring the cylinder diameter.

Limit of cylinder enlarging (boring):

0.5 mm (0.020 in)

3. PISTON AND PISTON PIN

1) Check the pistons and piston pins for damage, cracks, and wear and the piston ring grooves for wear and damage. Replace if defective.

2) Measure the piston-to-cylinder clearance at each cylinder. <Ref. to ME(H4SO)-81, CYLINDER AND PISTON, INSPECTION, Cylinder Block.> If any of the clearances is not to specification, replace the piston or bore the cylinder to use an oversize piston.

3) Make the sure that piston pin can be inserted into piston pin hole with a thumb at 20°C (68°F). Replace if defective.

Cylinder Block

MECHANICAL

Standard clearance between piston pin and hole in piston:

Standard

0.004 — 0.008 mm (0.0002 — 0.0003 in)

Limit

0.020 mm (0.0008 in)

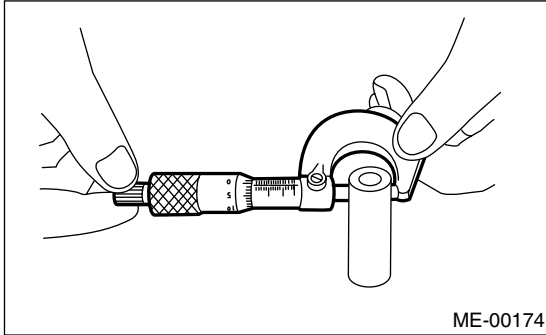
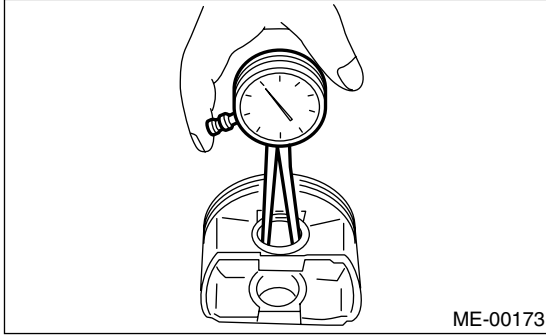

4) Check the circlip installation groove on piston for burr (A). If necessary, remove the burr from groove so that piston pin can lightly move.

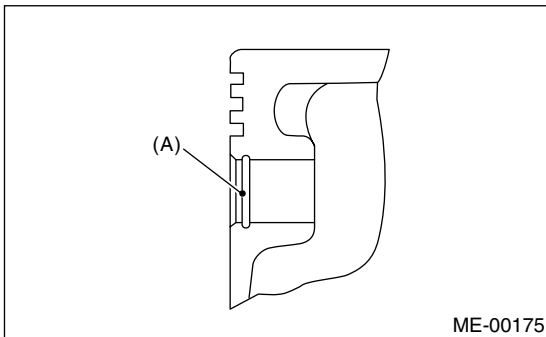

5) Check the piston pin circlip for distortion, cracks and wear.

4. PISTON RING

1) If the piston ring is broken, damaged, or worn, or if its tension is insufficient, or when the piston is replaced, replace the piston ring with a new one of the same size as the piston.

CAUTION:

• Marks are shown on the end of top and second rings. When installing the rings to piston, face these marks upward.

• Oil ring is composed of upper rail, expander and lower rail. Be careful of the rail direction when installing oil ring to the piston.

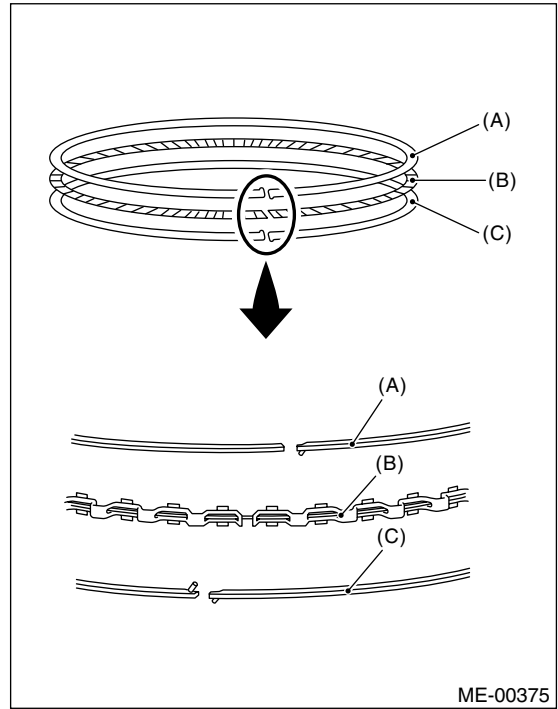

(A) Upper rail
(B) Expander
(C) Lower rail

2) Clean the piston ring groove and piston ring.

3) Squarely place the piston ring and oil ring in cylinder, and then measure the piston ring gap with a thickness gauge.

		Unit: mm (in)	
		Standard	Limit
Piston ring gap	Top ring	0.20 — 0.35 (0.0079 — 0.0138)	1.0 (0.039)
	Second ring	0.35 — 0.50 (0.0138 — 0.0197) 0.40 — 0.50 (0.0157 — 0.0197)*	1.0 (0.039)
	Oil ring rail	0.20 — 0.50 (0.0079 — 0.0197)	1.5 (0.059)

*: 2.0 L model

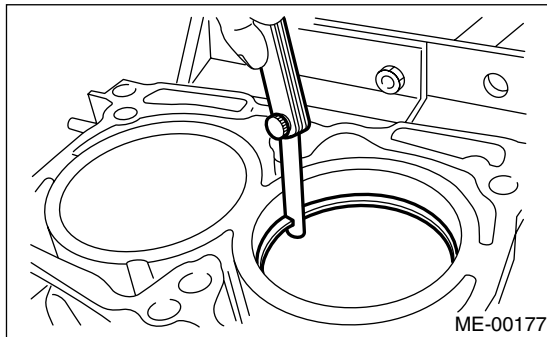

4) Measure the clearance between piston ring and piston ring groove with a thickness gauge.

		Unit: mm (in)	
		Standard	Limit
Clearance between piston ring and piston ring groove	Top ring	0.040 — 0.080 (0.0016 — 0.0031)	0.15 (0.0059)
	Second ring	0.030 — 0.070 (0.0012 — 0.0028)	0.15 (0.0059)

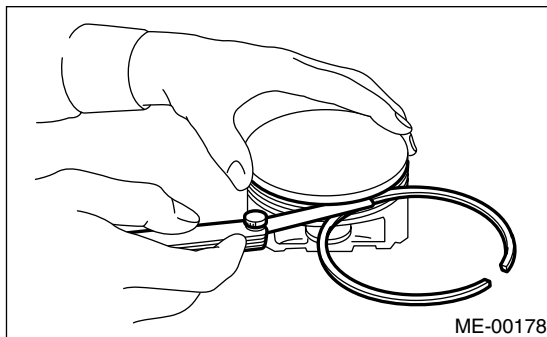

5. CONNECTING ROD

- 1) Replace the connecting rod, if the large or small end thrust surface is damaged.
- 2) Check for bend or twist using a connecting rod aligner. Replace the connecting rod if the bend or twist exceeds the limit.

Limit of bend or twist per 100 mm (3.94 in) in length:
0.10 mm (0.0039 in)

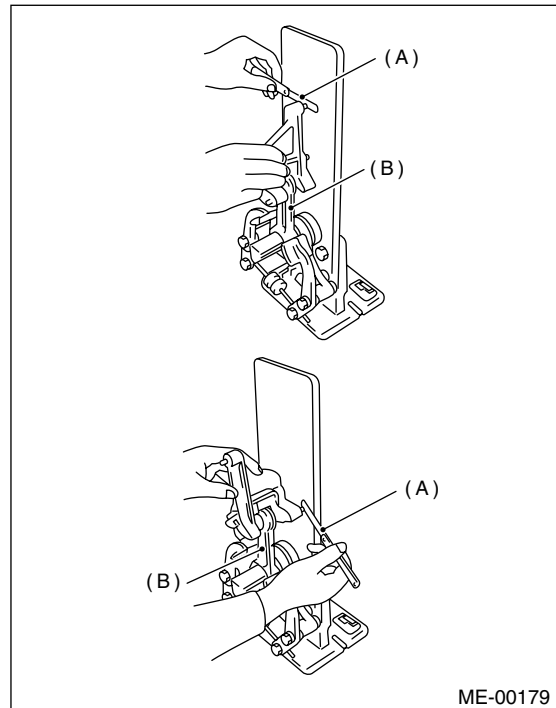

- (A) Thickness gauge
 (B) Connecting rod

3) Install the connecting rod fitted with bearing to crankshaft, and then measure the side clearance (thrust clearance). Replace the connecting rod if the side clearance exceeds the specified limit.

Connecting rod side clearance:

Standard

0.070 — 0.330 mm (0.0028 — 0.0130 in)

Limit

0.4 mm (0.016 in)

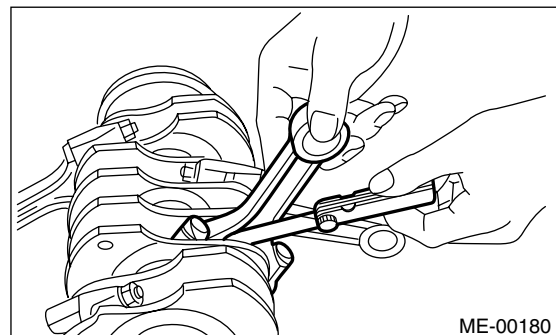

Cylinder Block

MECHANICAL

4) Inspect the connecting rod bearing for scar, peeling, seizure, melting, wear, etc.

5) Measure the oil clearance on individual connecting rod bearings by means of plastigauge. If any oil clearance is not within specification, replace the defective bearing with a new one of standard size or undersize as necessary. (See the table below.)

Connecting rod oil clearance:

1.6 L model

Standard

0.010 — 0.038 mm (0.0004 — 0.0015 in)

Limit

0.05 mm (0.0020 in)

Unit: mm (in)		
Bearing	Bearing size (Thickness at center)	Outer diameter of crank pin
Standard	1.492 — 1.501 (0.0587 — 0.0591)	47.984 — 48.000 (1.8891 — 1.8898)
0.03 (0.0012) undersize	1.510 — 1.513 (0.0594 — 0.0596)	47.954 — 47.970 (1.8879 — 1.8868)
0.05 (0.0020) undersize	1.520 — 1.523 (0.0598 — 0.0600)	47.934 — 47.950 (1.8872 — 1.8878)
0.25 (0.0098) undersize	1.620 — 1.623 (0.0638 — 0.0639)	47.734 — 47.750 (1.8793 — 1.8799)

2.0 L model

Standard

0.010 — 0.038 mm (0.0004 — 0.0015 in)

Limit

0.05 mm (0.0020 in)

Unit: mm (in)		
Bearing	Bearing size (Thickness at center)	Outer diameter of crank pin
Standard	1.492 — 1.501 (0.0587 — 0.0591)	51.984 — 52.000 (2.0466 — 2.0472)
0.03 (0.0012) undersize	1.510 — 1.513 (0.0594 — 0.0596)	51.954 — 51.970 (2.0454 — 2.0461)
0.05 (0.0020) undersize	1.520 — 1.523 (0.0598 — 0.0600)	51.934 — 51.950 (2.0446 — 2.0453)
0.25 (0.0098) undersize	1.620 — 1.623 (0.0638 — 0.0639)	51.734 — 51.750 (2.0368 — 2.0374)

2.5 L model

Standard

0.020 — 0.046 mm (0.0008 — 0.0018 in)

Limit

0.05 mm (0.0020 in)

Unit: mm (in)		
Bearing	Bearing size (Thickness at center)	Outer diameter of crank pin
Standard	1.490 — 1.502 (0.0587 — 0.0591)	51.984 — 52.000 (2.0466 — 2.0472)
0.03 (0.0012) undersize	1.504 — 1.512 (0.0592 — 0.0595)	51.954 — 51.970 (2.0454 — 2.0461)
0.05 (0.0020) undersize	1.514 — 1.522 (0.0596 — 0.0599)	51.934 — 51.950 (2.0446 — 2.0453)
0.25 (0.0098) undersize	1.614 — 1.622 (0.0635 — 0.0639)	51.734 — 51.750 (2.0368 — 2.0374)

6) Inspect the bushing at connecting rod small end, and replace if worn or damaged. Also measure the piston pin clearance at connecting rod small end.

Clearance between piston pin and bushing:

Standard

0 — 0.022 mm (0 — 0.0009 in)

Limit

0.030 mm (0.0012 in)

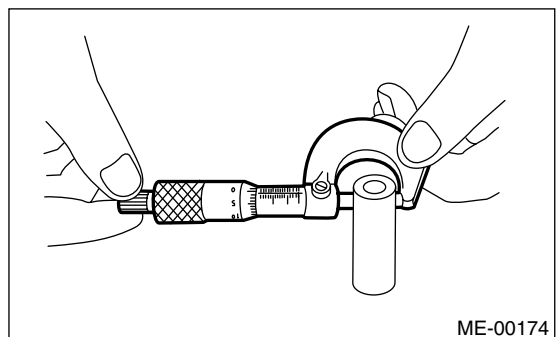
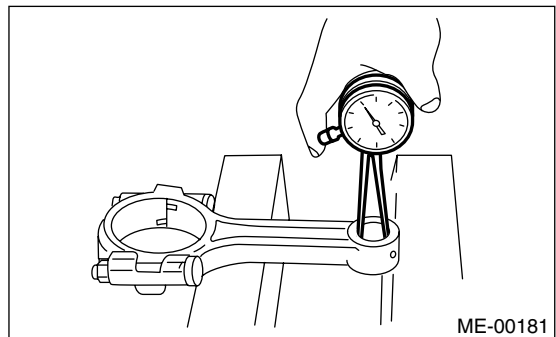

- 7) Replacement procedure is as follows.
- (1) Remove the bushing from connecting rod with ST and press.
 - (2) Press the bushing with ST after applying oil on the periphery of bushing.

ST 499037100 CONNECTING ROD BUSHING REMOVER AND INSTALLER

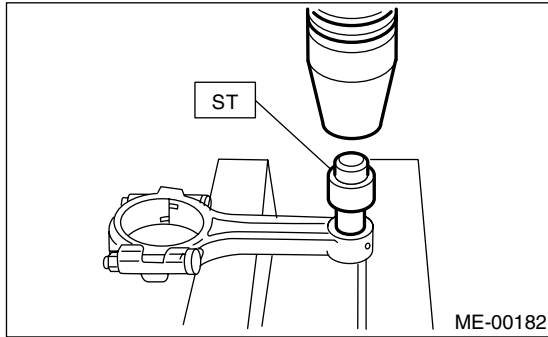

- (3) Make two 3 mm (0.12 in) holes in bushing. Ream the inside of bushing.
- (4) After the completion of reaming, clean the bushing to remove chips.

6. CRANKSHAFT AND CRANKSHAFT BEARING

- 1) Clean the crankshaft completely and check for cracks by means of red lead check etc., and replace if defective.
- 2) Measure the crankshaft bend, and correct or replace if it exceeds the limit.

NOTE:

If a suitable V-block is not available, install the #1 and #5 crankshaft bearing on cylinder block, position the crankshaft on these bearings and measure the crankshaft bend using a dial gauge.

Crankshaft bend limit:
0.035 mm (0.0014 in)

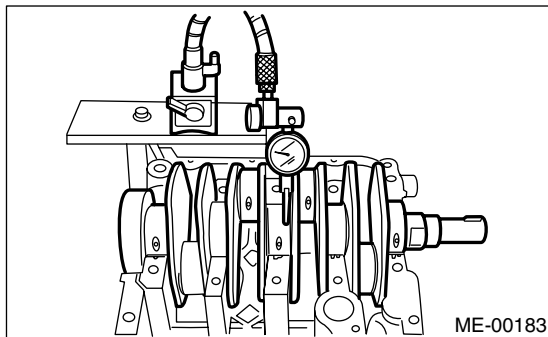

- 3) Inspect the crank journal and crank pin for wear. If they are not within the specifications, replace the bearing with a suitable (undersize) one, and then replace or recondition the crankshaft as necessary. When grinding the crank journal or crank pin, finish them to specified dimensions according to the undersize bearing to be used.

Crank pin and crank journal:

Out-of-roundness

0.020 mm (0.0008 in) or less

Taper limit

0.07 mm (0.0028 in)

Grinding limit

0.250 mm (0.0098 in)

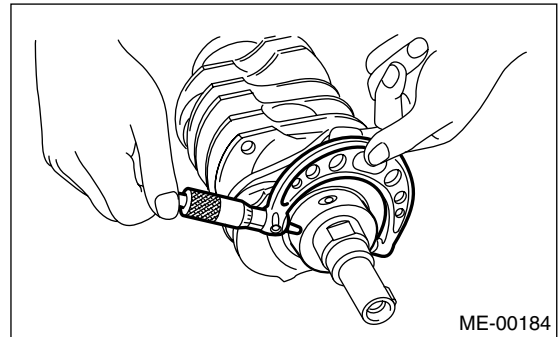

Cylinder Block

MECHANICAL

		Unit: mm (in)				
		Crank journal diameter		Crank pin diameter		
		#1, #3	#2, #4, #5	1.6 L	2.0 L	2.5 L
Standard	Journal O.D.	59.992 — 60.008 (2.3619 — 2.3625)	59.992 — 60.008 (2.3619 — 2.3625)	47.984 — 48.000 (1.8891 — 1.8898)	51.984 — 52.000 (2.0466 — 2.0472)	51.984 — 52.000 (2.0466 — 2.0472)
	Bearing size (Thickness at center)	1.998 — 2.011 (0.0787 — 0.0792)	2.000 — 2.013 (0.0787 — 0.0793)	1.492 — 1.510 (0.0587 — 0.0594)	1.492 — 1.501 (0.0587 — 0.0591)	1.490 — 1.502 (0.0587 — 0.0591)
0.03 (0.0012) undersize	Journal O.D.	59.962 — 59.978 (2.3607 — 2.3613)	59.962 — 59.978 (2.3607 — 2.3613)	47.954 — 47.970 (1.8879 — 1.8886)	51.954 — 51.970 (2.0454 — 2.0461)	51.954 — 51.970 (2.0454 — 2.0461)
	Bearing size (Thickness at center)	2.017 — 2.020 (0.0794 — 0.0795)	2.019 — 2.022 (0.0795 — 0.0796)	1.510 — 1.513 (0.0594 — 0.0596)	1.510 — 1.513 (0.0594 — 0.0596)	1.504 — 1.512 (0.0592 — 0.0595)
0.05 (0.0020) undersize	Journal O.D.	59.942 — 59.958 (2.3599 — 2.3605)	59.942 — 59.958 (2.3599 — 2.3605)	47.934 — 47.950 (1.8872 — 1.8878)	51.934 — 51.950 (2.0446 — 2.0453)	51.934 — 51.950 (2.0446 — 2.0453)
	Bearing size (Thickness at center)	2.027 — 2.030 (0.0798 — 0.0799)	2.029 — 2.032 (0.0799 — 0.0800)	1.520 — 1.523 (0.0598 — 0.0600)	1.520 — 1.523 (0.0598 — 0.0600)	1.514 — 1.522 (0.0596 — 0.0599)
0.25 (0.0098) undersize	Journal O.D.	59.742 — 59.758 (2.3520 — 2.3527)	59.742 — 59.758 (2.3520 — 2.3527)	47.734 — 47.750 (1.8793 — 1.8799)	51.734 — 51.750 (2.0368 — 2.0374)	51.734 — 51.750 (2.0368 — 2.0374)
	Bearing size (Thickness at center)	2.127 — 2.130 (0.0837 — 0.0839)	2.129 — 2.132 (0.0838 — 0.0839)	1.620 — 1.623 (0.0638 — 0.0639)	1.620 — 1.623 (0.0638 — 0.0639)	1.614 — 1.622 (0.0635 — 0.0639)

O.D.: Outer Diameter

4) Measure the thrust clearance of crankshaft at center bearing. If the clearance exceeds the limit, replace bearing.

Crankshaft thrust clearance:

Standard

0.030 — 0.115 mm (0.0012 — 0.0045 in)

Limit

0.25 mm (0.0098 in)

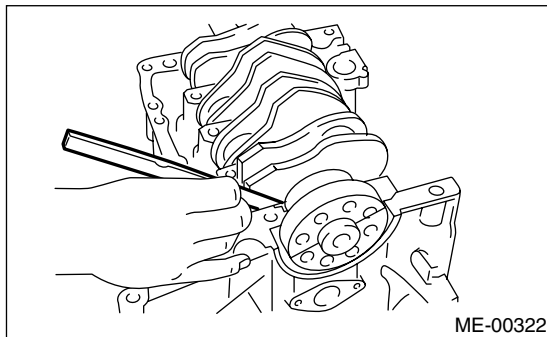

5) Inspect the individual crankshaft bearings for signs of flaking, seizure, melting, and wear.

6) Measure the oil clearance on each crankshaft bearing by means of plastigauge. If the measurement is not within the specification, replace the defective bearing with an undersize one, and then replace or recondition the crankshaft as necessary.

Unit: mm (in)		
Crankshaft oil clearance		
#1	Standard	0.010 — 0.030 (0.0004 — 0.0012)
	Limit	0.040 (0.0016)
#2	Standard	0.010 — 0.030 (0.0004 — 0.0012)
	Limit	0.045 (0.0018)
#3	Standard	0.010 — 0.030 (0.0004 — 0.0012)
	Limit	0.040 (0.0016)
#4	Standard	0.010 — 0.030 (0.0004 — 0.0012)
	Limit	0.045 (0.0018)
#5	Standard	0.010 — 0.030 (0.0004 — 0.0012)
	Limit	0.040 (0.0016)

22.Engine Trouble in General

A: INSPECTION

NOTE:

“RANK” shown in the chart refer to the possibility of reason for the trouble in order (“Very often” to “Rarely”)

A — Very often

B — Sometimes

C — Rarely

TROUBLE	PROBLEM PARTS, ETC.	POSSIBLE CAUSE	RANK
1. Engine will not start.			
1) Starter does not turn.	Starter	Defective battery-to-starter harness	B
		Defective starter switch	C
		Defective inhibitor switch or neutral switch	C
		Defective starter	B
	Battery	Poor terminal connection	A
		Run-down battery	A
		Defective charging system	B
	Friction	Seizure of crankshaft and connecting rod bearing	C
		Seized camshaft	C
Seized or stuck piston and cylinder		C	
2) Initial combustion does not occur.	Starter	Defective starter	C
	Engine control system <Ref. to EN(H4SO)(diag)-2, Basic Diagnostic Procedure.> or <Ref. to EN(H4SOw/oOBD)(diag)-2, Basic Diagnostic Procedure.>		A
	Fuel line	Defective fuel pump and relay	A
		Lack of or insufficient fuel	B
	Belt	Defective	B
		Defective timing	B
	Compression	Incorrect valve clearance	C
		Loosened spark plugs or defective gasket	C
		Loosened cylinder head bolts or defective gasket	C
		Improper valve seating	C
		Defective valve stem	C
		Worn or broken valve spring	B
		Worn or stuck piston rings, cylinder and piston	C
Incorrect valve timing		B	
Improper engine oil (low viscosity)	B		

Engine Trouble in General

MECHANICAL

TROUBLE	PROBLEM PARTS, ETC.	POSSIBLE CAUSE	RANK
3) Initial combustion occurs.	Engine control system <Ref. to EN(H4SO)(diag)-2, Basic Diagnostic Procedure.> or <Ref. to EN(H4SOw/oOBD)(diag)-2, Basic Diagnostic Procedure.>		A
	Intake system	Defective intake manifold gasket	B
		Defective throttle body gasket	B
	Fuel line	Defective fuel pump and relay	C
		Clogged fuel line	C
		Lack of or insufficient fuel	B
	Belt	Defective	B
		Defective timing	B
	Compression	Incorrect valve clearance	C
		Loosened spark plugs or defective gasket	C
		Loosened cylinder head bolts or defective gasket	C
		Improper valve seating	C
		Defective valve stem	C
		Worn or broken valve spring	B
		Worn or stuck piston rings, cylinder and piston	C
Incorrect valve timing		B	
Improper engine oil (low viscosity)	B		
4) Engine stalls after initial combustion.	Engine control system <Ref. to EN(H4SO)(diag)-2, Basic Diagnostic Procedure.> or <Ref. to EN(H4SOw/oOBD)(diag)-2, Basic Diagnostic Procedure.>		A
	Intake system	Loosened or cracked intake duct	B
		Loosened or cracked PCV hose	C
		Loosened or cracked vacuum hose	C
		Defective intake manifold gasket	B
		Defective throttle body gasket	B
		Dirty air cleaner element	C
	Fuel line	Clogged fuel line	C
		Lack of or insufficient fuel	B
	Belt	Defective	B
		Defective timing	B
	Compression	Incorrect valve clearance	C
		Loosened spark plugs or defective gasket	C
		Loosened cylinder head bolts or defective gasket	C
		Improper valve seating	C
Defective valve stem		C	
Worn or broken valve spring		B	
Worn or stuck piston rings, cylinder and piston		C	
Incorrect valve timing		B	
Improper engine oil (low viscosity)	B		

Engine Trouble in General

MECHANICAL

TROUBLE	PROBLEM PARTS, ETC.	POSSIBLE CAUSE	RANK
2. Rough idle and engine stall	Engine control system <Ref. to EN(H4SO)(diag)-2, Basic Diagnostic Procedure.> or <Ref. to EN(H4SOw/oOBD)(diag)-2, Basic Diagnostic Procedure.>		A
	Intake system	Loosened or cracked intake duct	A
		Loosened or cracked PCV hose	A
		Loosened or cracked vacuum hose	A
		Defective intake manifold gasket	B
		Defective throttle body gasket	B
		Defective PCV valve	C
		Loosened oil filler cap	B
		Dirty air cleaner element	C
	Fuel line	Defective fuel pump and relay	C
		Clogged fuel line	C
		Lack of or insufficient fuel	B
	Belt	Defective timing	C
	Compression	Incorrect valve clearance	B
		Loosened spark plugs or defective gasket	B
		Loosened cylinder head bolts or defective gasket	B
		Improper valve seating	B
		Defective valve stem	C
		Worn or broken valve spring	B
		Worn or stuck piston rings, cylinder and piston	B
		Incorrect valve timing	A
		Improper engine oil (low viscosity)	B
	Lubrication system	Incorrect oil pressure	B
Defective rocker cover gasket		C	
Cooling system	Overheating	C	
Others	Malfunction of evaporative emission control system	A	
	Stuck or damaged throttle valve	B	
	Accelerator cable out of adjustment	C	

Engine Trouble in General

MECHANICAL

TROUBLE	PROBLEM PARTS, ETC.	POSSIBLE CAUSE	RANK
3. Low output, hesitation and poor acceleration	Engine control system <Ref. to EN(H4SO)(diag)-2, Basic Diagnostic Procedure.> or <Ref. to EN(H4SOw/oOBD)(diag)-2, Basic Diagnostic Procedure.>		A
	Intake system	Loosened or cracked intake duct	A
		Loosened or cracked PCV hose	A
		Loosened or cracked vacuum hose	B
		Defective intake manifold gasket	B
		Defective throttle body gasket	B
		Defective PCV valve	B
		Loosened oil filler cap	B
		Dirty air cleaner element	A
	Fuel line	Defective fuel pump and relay	B
		Clogged fuel line	B
		Lack of or insufficient fuel	C
	Belt	Defective timing	B
	Compression	Incorrect valve clearance	B
		Loosened spark plugs or defective gasket	B
		Loosened cylinder head bolts or defective gasket	B
		Improper valve seating	B
		Defective valve stem	C
		Worn or broken valve spring	B
		Worn or stuck piston rings, cylinder and piston	C
		Incorrect valve timing	A
	Improper engine oil (low viscosity)	B	
	Lubrication system	Incorrect oil pressure	B
	Cooling system	Overheating	C
		Over cooling	C
	Others	Malfunction of evaporative emission control system	A
4. Surging	Engine control system <Ref. to EN(H4SO)(diag)-2, Basic Diagnostic Procedure.> or <Ref. to EN(H4SOw/oOBD)(diag)-2, Basic Diagnostic Procedure.>		A
	Intake system	Loosened or cracked intake duct	A
		Loosened or cracked PCV hose	A
		Loosened or cracked vacuum hose	A
		Defective intake manifold gasket	B
		Defective throttle body gasket	B
		Defective PCV valve	B
		Loosened oil filler cap	B
		Dirty air cleaner element	B
	Fuel line	Defective fuel pump and relay	B
		Clogged fuel line	B
		Lack of or insufficient fuel	C
	Belt	Defective timing	B
	Compression	Incorrect valve clearance	B
		Loosened spark plugs or defective gasket	C
		Loosened cylinder head bolts or defective gasket	C
		Improper valve seating	C
		Defective valve stem	C
		Worn or broken valve spring	C
		Worn or stuck piston rings, cylinder and piston	C
		Incorrect valve timing	A
	Improper engine oil (low viscosity)	B	
	Cooling system	Overheating	B
	Others	Malfunction of evaporative emission control system	C

Engine Trouble in General

MECHANICAL

TROUBLE	PROBLEM PARTS, ETC.	POSSIBLE CAUSE	RANK
5. Engine does not return to idle.	Engine control system <Ref. to EN(H4SO)(diag)-2, Basic Diagnostic Procedure.> or <Ref. to EN(H4SOw/oOBD)(diag)-2, Basic Diagnostic Procedure.>		A
	Intake system	Loosened or cracked vacuum hose	A
	Others	Stuck or damaged throttle valve	A
		Accelerator cable out of adjustment	B
6. Dieseling (Run-on)	Engine control system <Ref. to EN(H4SO)(diag)-2, Basic Diagnostic Procedure.> or <Ref. to EN(H4SOw/oOBD)(diag)-2, Basic Diagnostic Procedure.>		A
	Cooling system	Overheating	B
	Others	Malfunction of evaporative emission control system	B
7. After burning in exhaust system	Engine control system <Ref. to EN(H4SO)(diag)-2, Basic Diagnostic Procedure.> or <Ref. to EN(H4SOw/oOBD)(diag)-2, Basic Diagnostic Procedure.>		A
	Intake system	Loosened or cracked intake duct	C
		Loosened or cracked PCV hose	C
		Loosened or cracked vacuum hose	B
		Defective PCV valve	B
		Loosened oil filler cap	C
	Belt	Defective timing	B
	Compression	Incorrect valve clearance	B
		Loosened spark plugs or defective gasket	C
		Loosened cylinder head bolts or defective gasket	C
		Improper valve seating	B
		Defective valve stem	C
		Worn or broken valve spring	C
		Worn or stuck piston rings, cylinder and piston	C
	Incorrect valve timing	A	
	Lubrication system	Incorrect oil pressure	C
Cooling system	Over cooling	C	
Others	Malfunction of evaporative emission control system	C	
8. Knocking	Engine control system <Ref. to EN(H4SO)(diag)-2, Basic Diagnostic Procedure.> or <Ref. to EN(H4SOw/oOBD)(diag)-2, Basic Diagnostic Procedure.>		A
	Intake system	Loosened oil filler cap	B
	Belt	Defective timing	B
	Compression	Incorrect valve clearance	C
		Incorrect valve timing	B
	Cooling system	Overheating	A
9. Excessive engine oil consumption	Intake system	Loosened or cracked PCV hose	A
		Defective PCV valve	B
		Loosened oil filler cap	C
	Compression	Defective valve stem	A
		Worn or stuck piston rings, cylinder and piston	A
	Lubrication system	Loosened oil pump attaching bolts and defective gasket	B
		Defective oil filter seal	B
		Defective crankshaft oil seal	B
		Defective rocker cover gasket	B
		Loosened oil drain plug or defective gasket	B
Loosened oil pan fitting bolts or defective oil pan	B		

Engine Trouble in General

MECHANICAL

TROUBLE	PROBLEM PARTS, ETC.	POSSIBLE CAUSE	RANK	
10. Excessive fuel consumption	Engine control system <Ref. to EN(H4SO)(diag)-2, Basic Diagnostic Procedure.> or <Ref. to EN(H4SOw/oOBD)(diag)-2, Basic Diagnostic Procedure.>		A	
	Intake system	Dirty air cleaner element	A	
	Belt	Defective timing	B	
	Compression	Incorrect valve clearance		B
		Loosened spark plugs or defective gasket		C
		Loosened cylinder head bolts or defective gasket		C
		Improper valve seating		B
		Defective valve stem		C
		Worn or broken valve spring		C
		Worn or stuck piston rings, cylinder and piston		B
		Incorrect valve timing		B
	Lubrication system	Incorrect oil pressure	C	
	Cooling system	Over cooling	C	
	Others	Accelerator cable out of adjustment	B	

23.Engine Noise

A: INSPECTION

Type of sound	Condition	Possible cause
Regular clicking sound	Sound increases as engine speed increases.	<ul style="list-style-type: none"> • Valve mechanism is defective. • Incorrect valve clearance • Worn valve rocker • Worn camshaft • Broken valve spring
Heavy and dull clank	Oil pressure is low.	<ul style="list-style-type: none"> • Worn crankshaft main bearing • Worn connecting rod bearing (big end)
	Oil pressure is normal.	<ul style="list-style-type: none"> • Loose flywheel mounting bolts • Damaged engine mounting
High-pitched clank (Spark knock)	Sound is noticeable when accelerating with an overload.	<ul style="list-style-type: none"> • Ignition timing advanced • Accumulation of carbon inside combustion chamber • Wrong spark plug • Improper gasoline
Clank when engine speed is medium (1,000 to 2,000 rpm).	Sound is reduced when fuel injector connector of noisy cylinder is disconnected. (NOTE*)	<ul style="list-style-type: none"> • Worn crankshaft main bearing • Worn bearing at crankshaft end of connecting rod
Knocking sound when engine is operating under idling speed and engine is warm	Sound is reduced when fuel injector connector of noisy cylinder is disconnected. (NOTE*)	<ul style="list-style-type: none"> • Worn cylinder liner and piston ring • Broken or stuck piston ring • Worn piston pin and hole at piston end of connecting rod
	Sound is not reduced if each fuel injector connector is disconnected in turn. (NOTE*)	<ul style="list-style-type: none"> • Unusually worn valve lifter • Worn cam gear • Worn camshaft journal bore in crankcase
Squeaky sound	—	<ul style="list-style-type: none"> • Insufficient generator lubrication
Rubbing sound	—	<ul style="list-style-type: none"> • Defective generator brush and rotor contact
Gear scream when starting engine	—	<ul style="list-style-type: none"> • Defective ignition starter switch • Worn gear and starter pinion
Sound like polishing glass with a dry cloth	—	<ul style="list-style-type: none"> • Loose drive belt • Defective water pump shaft
Hissing sound	—	<ul style="list-style-type: none"> • Loss of compression • Air leakage in air intake system, hoses, connections or manifolds
Timing belt noise	—	<ul style="list-style-type: none"> • Loose timing belt • Belt contacting case/adjacent part
Valve tappet noise	—	<ul style="list-style-type: none"> • Incorrect valve clearance

NOTE*:

When disconnecting the fuel injector connector, Malfunction Indicator Light illuminates and DTC is stored in ECM memory. Therefore, carry out the CLEAR MEMORY MODE <Ref. to EN(H4SO)(diag)-47, OPERATION, Clear Memory Mode.> or <Ref. to EN(H4SOw/oOBD)(diag)-28, OPERATION, Clear Memory Mode.> and INSPECTION MODE <Ref. to EN(H4SO)(diag)-40, OPERATION, Inspection Mode.> or <Ref. to EN(H4SOw/oOBD)(diag)-26, OPERATION, Inspection Mode.> after connecting fuel injector connector.

Engine Noise

MECHANICAL
