

ENGINE SECTION 2

This service manual has been prepared to provide SUBARU service personnel with the necessary information and data for the correct maintenance and repair of SUBARU vehicles.

This manual includes the procedures for maintenance, disassembling, reassembling, inspection and adjustment of components and diagnostics for guidance of experienced mechanics.

Please peruse and utilize this manual fully to ensure complete repair work for satisfying our customers by keeping their vehicle in optimum condition. When replacement of parts during repair work is needed, be sure to use SUBARU genuine parts.

All information, illustration and specifications contained in this manual are based on the latest product information available at the time of publication approval.

FUEL INJECTION (FUEL SYSTEMS) FU(H4DOTC)

EMISSION CONTROL (AUX. EMISSION CONTROL DEVICES) EC(H4DOTC)

INTAKE (INDUCTION) IN(H4DOTC)

MECHANICAL ME(H4DOTC)

EXHAUST EX(H4DOTC)

COOLING CO(H4DOTC)

LUBRICATION LU(H4DOTC)

SPEED CONTROL SYSTEMS SP(H4DOTC)

IGNITION IG(H4DOTC)

STARTING/CHARGING SYSTEMS SC(H4DOTC)

ENGINE (DIAGNOSTICS) EN(H4DOTC)(diag)

EMISSION CONTROL (AUX. EMISSION CONTROL DEVICES) *EC(H4DOTC)*

	Page
1. General Description	2
2. Front Catalytic Converter	3
3. Rear Catalytic Converter	4
4. Precatalytic Converter	5
5. Canister	6
6. Purge Control Solenoid Valve	7
7. Two-way Valve	8

General Description

EMISSION CONTROL (AUX. EMISSION CONTROL DEVICES)

1. General Description

A: CAUTION

- Wear working clothing, including a cap, protective goggles, and protective shoes during operation.
- Remove contamination including dirt and corrosion before removal, installation or disassembly.
- Keep the disassembled parts in order and protect them from dust or dirt.
- Before removal, installation or disassembly, be sure to clarify the failure. Avoid unnecessary removal, installation, disassembly, and replacement.
- Be careful not to burn your hands, because each part on the vehicle is hot after running.
- Be sure to tighten fasteners including bolts and nuts to the specified torque.
- Place shop jacks or safety stands at the specified points.
- Before disconnecting electrical connectors of sensors or units, be sure to disconnect the ground cable from battery.

Front Catalytic Converter

EMISSION CONTROL (AUX. EMISSION CONTROL DEVICES)

2. Front Catalytic Converter

A: REMOVAL

1) Remove the front catalytic converter and center exhaust pipe as a unit. <Ref. to EX(H4DOTC)-9, REMOVAL, Center Exhaust Pipe.>

2) Separate the front catalytic converter (A) from rear catalytic converter (B). (Except for Australia model)

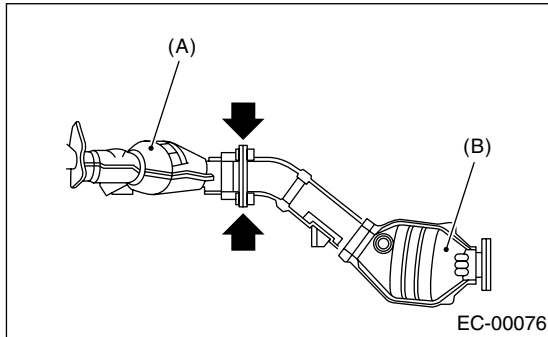

B: INSTALLATION

NOTE:

Replace the gaskets with new ones.
Install in the reverse order of removal.

C: INSPECTION

- 1) Make sure there are no exhaust leaks from connections and welds.
- 2) Make sure there are no holes or rusting.

Rear Catalytic Converter

EMISSION CONTROL (AUX. EMISSION CONTROL DEVICES)

3. Rear Catalytic Converter

A: REMOVAL

1) Remove the rear catalytic converter and center exhaust pipe as a unit. <Ref. to EX(H4DOTC)-9, REMOVAL, Center Exhaust Pipe.>

2) Separate the rear catalytic converter (B) from front catalytic converter (A). (Except for Australia model)

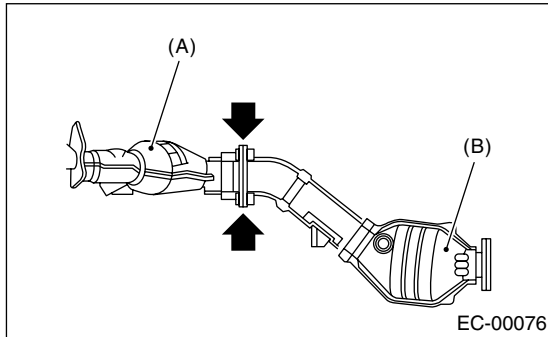

B: INSTALLATION

NOTE:

Replace the gaskets with new ones.
Install in the reverse order of removal.

C: INSPECTION

- 1) Make sure there are no exhaust leaks from connections and welds.
- 2) Make sure there are no holes or rusting.

Precatalytic Converter

EMISSION CONTROL (AUX. EMISSION CONTROL DEVICES)

4. Precatalytic Converter

A: REMOVAL

NOTE:

Precatalytic converter is equipped on models except for STi and Australia model.

Precatalytic converter (A) is built in the joint pipe. Refer to the removal of joint pipe for removal procedure. <Ref. to EX(H4DOTC)-13, REMOVAL, Joint Pipe.>

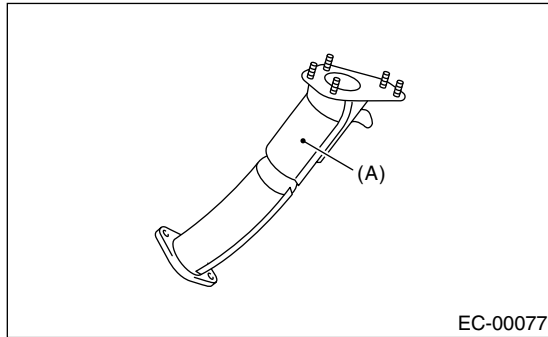

B: INSTALLATION

Install in the reverse order of removal.

C: INSPECTION

- 1) Make sure there are no exhaust leaks from connections and welds.
- 2) Make sure there are no holes or rusting.

Canister

EMISSION CONTROL (AUX. EMISSION CONTROL DEVICES)

5. Canister

A: REMOVAL

- 1) Lift-up the vehicle.
- 2) Loosen the two clamps which hold the two canister hoses, and then disconnect the three evaporation hoses from canister.

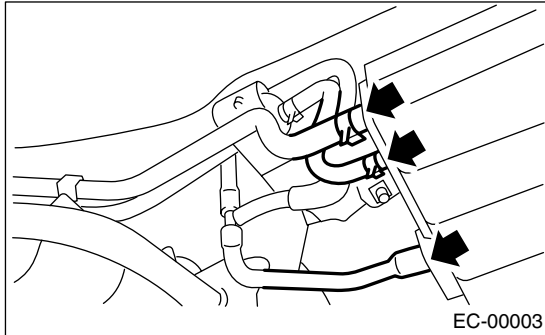

- 3) Remove the canister from body.

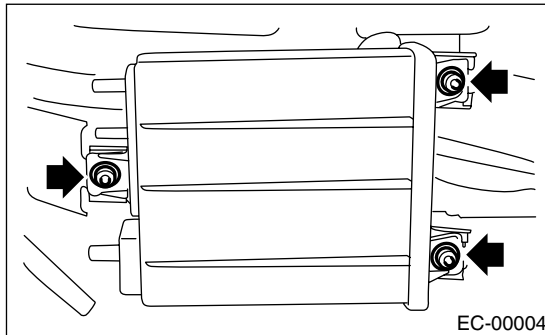

B: INSTALLATION

Install in the reverse order of removal.

Tightening torque:

23 N·m (2.3 kgf·m, 17 ft·lb)

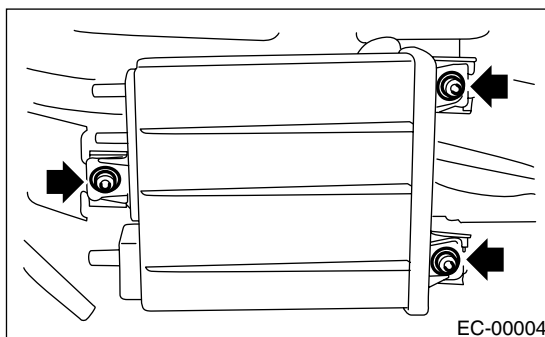

C: INSPECTION

Make sure the canister and canister hoses are not cracked or loose.

Purge Control Solenoid Valve

EMISSION CONTROL (AUX. EMISSION CONTROL DEVICES)

6. Purge Control Solenoid Valve

A: REMOVAL

1) Disconnect the ground cable from battery.

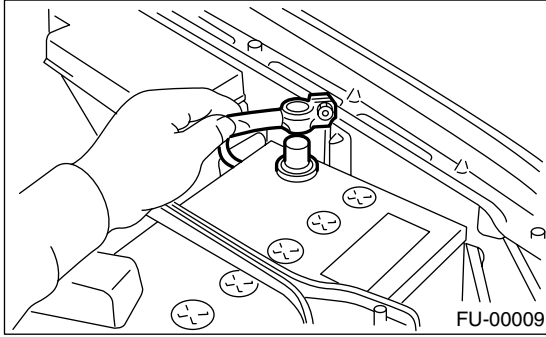

2) Disconnect the connector and hoses from purge control solenoid valve.

3) Remove the bolt which installs the purge control solenoid valve onto intake manifold.

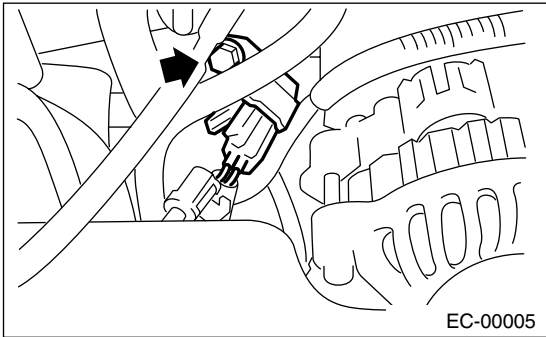

B: INSTALLATION

Install in the reverse order of removal.

Tightening torque:

19 N·m (1.9 kgf·m, 13.7 ft·lb)

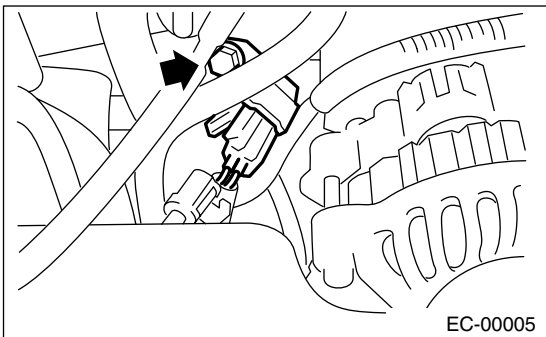

NOTE:

Connect the evaporation hoses as shown in the figure.

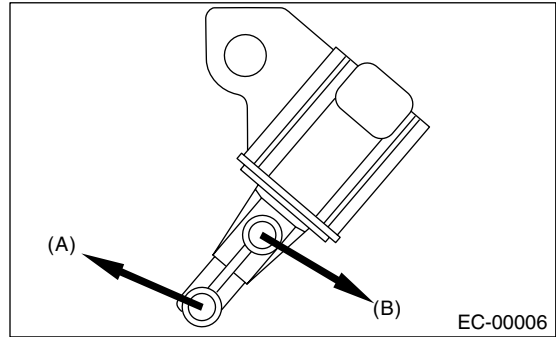

(A) To intake manifold

(B) To purge valve (Except for Australia model)
To fuel pipe (Australia model)

C: INSPECTION

Make sure the hoses are not cracked or loose.

Two-way Valve

EMISSION CONTROL (AUX. EMISSION CONTROL DEVICES)

7. Two-way Valve

A: REMOVAL

- 1) Lift-up the vehicle.
- 2) Remove the canister from body. <Ref. to EC(H4DOTC)-6, REMOVAL, Canister.>
- 3) Remove the two-way valve with bracket as a unit from body.

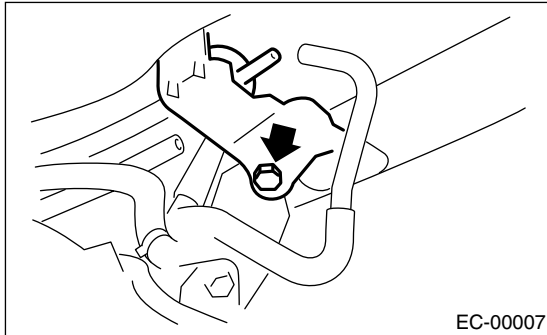

- 4) Remove the two-way valve from bracket.

B: INSTALLATION

Install in the reverse order of removal.

C: INSPECTION

Make sure that the hoses are not cracked or loose.