

BODY ELECTRICAL SYSTEM

6-2

Page

S SPECIFICATIONS AND SERVICE DATA

1. Body Electrical

W SERVICE PROCEDURE.....2

1. Precaution
2. Battery
3. Ignition Key Switch
4. Lighting
5. Front Wiper and Washer
6. Rear Wiper and Washer
7. Rear Window Defogger
8. Combination Meter
9. Radio
10. Towing Power Connector
11. Cruise Control.....2
12. Vehicle Speed Sensor 2 (Turbo model)6

11. Cruise Control

A: ADJUSTMENT

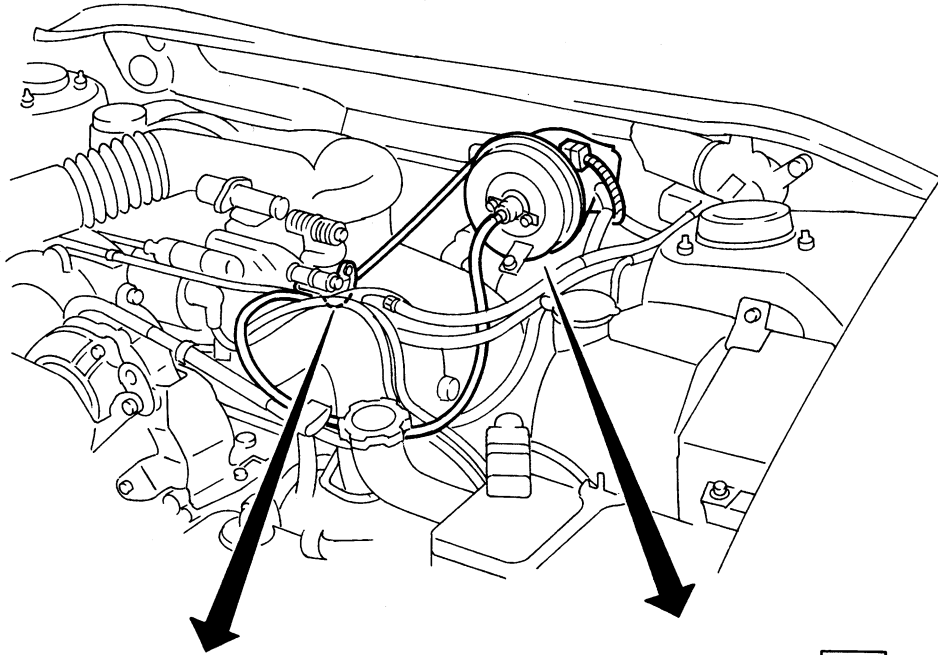

Adjust so that cable deflects
1 – 8 mm (0.04 – 0.31 in) within
the specified throttle link free
play range, and adjust the outer
end.

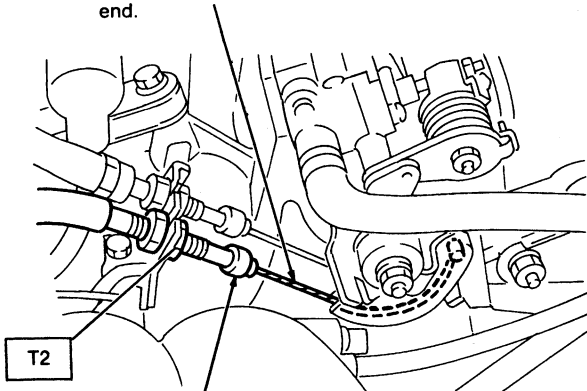

Cover must be inserted securely,
until top of cable touches cover
stopper.

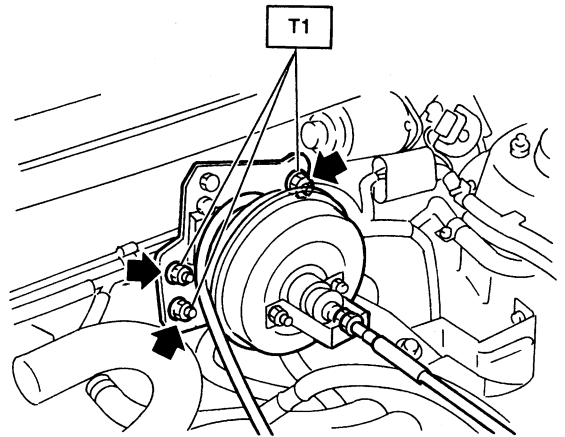

Tightening torque: N·m (kg-m, ft-lb)

T1: 5.4 – 9.3 (0.55 – 0.95, 4.0 – 6.9)

T2: 10 – 18 (1.0 – 1.8, 7 – 13)

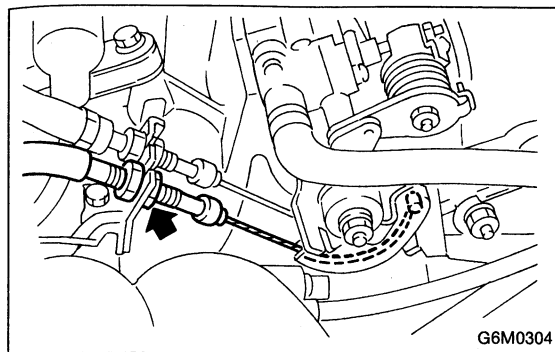

B: REMOVAL AND INSTALLATION

Remove each part as described below.
And, install in the reverse order of removal.

1. ACTUATOR

- 1) Remove the nut which secures control cable end to throttle cam, and remove control cable end.
- 2) Remove clip bands from control cable.

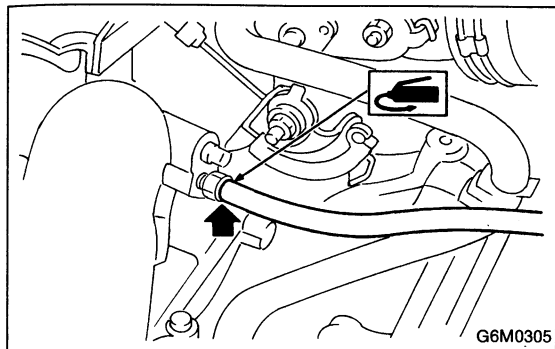

- 3) Disconnect cruise control hose from intake manifold.

CAUTION:

When inserting hose into intake manifold, apply sealant to hose.

Fluid packing:

THREE BOND 1105 or equivalent

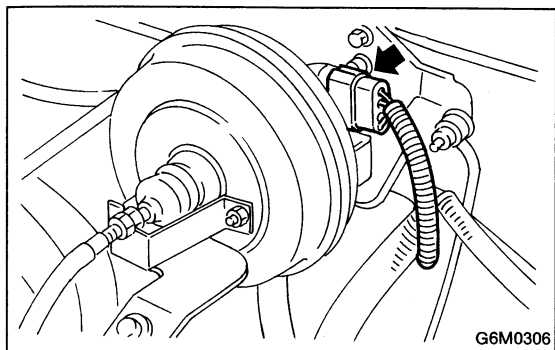

- 4) Disconnect connector from actuator.

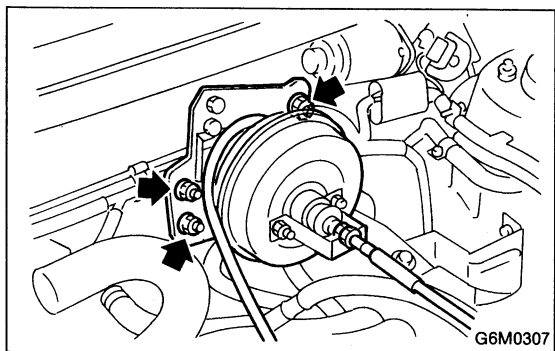

- 5) Remove actuator.

Tightening torque:

5.4 — 9.3 N·m (0.55 — 0.95 kg-m, 4.0 — 6.9 ft-lb)

CAUTION:

- Be careful not to apply excessive load to the wire cable when adjusting and/or installing; otherwise, the actuator may be deformed or damaged.
- Do not bend cable sharply with a radius less than 100 mm (3.94 in); otherwise, cable may bend permanently, resulting in poor performance.
- When installing cable, be careful not to sharply bend or pinch the inner cable; otherwise, the cable may break.

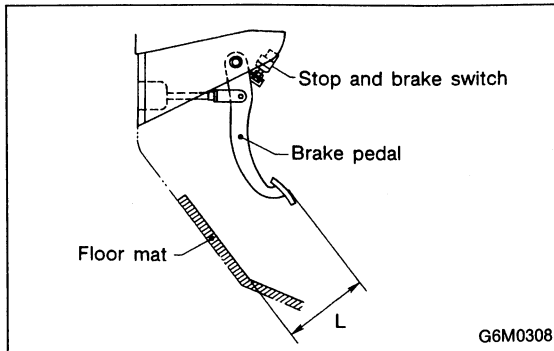

2. STOP AND BRAKE SWITCH

- 1) Disconnect stop and brake switch connector.
- 2) Remove stop and brake switch.

NOTE:

During installation, set brake pedal position by adjusting position of stop and brake switch.

Pedal position L:

125.9 mm (4.96 in)

Stop and brake switch tightening torque:

6 — 10 N·m (0.6 — 1.0 kg-m, 4.3 — 7.2 ft-lb)

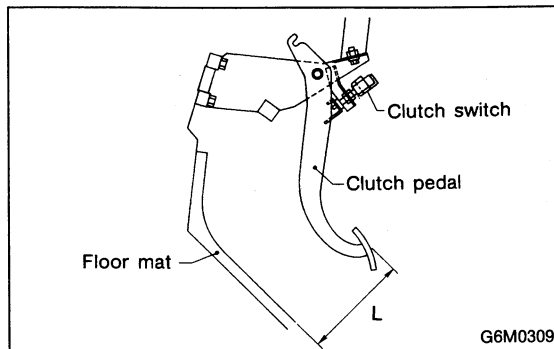

3. CLUTCH SWITCH

- 1) Disconnect clutch switch connector.
- 2) Remove clutch switch.

NOTE:

During installation, set clutch pedal position by adjusting position of clutch switch.

Pedal position L (distance between floor mat and pedal face):

142 — 150 mm (5.59 — 5.91 in)

Clutch switch tightening torque:

6 — 10 N·m (0.6 — 1.0 kg-m, 4.3 — 7.2 ft-lb)

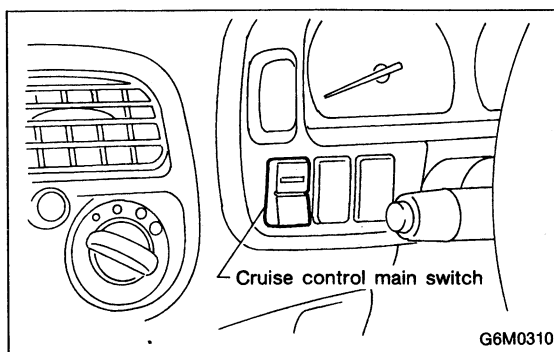

4. CRUISE CONTROL MAIN SWITCH

- 1) Remove meter visor.
- 2) Remove cruise control main switch by pushing it outward.

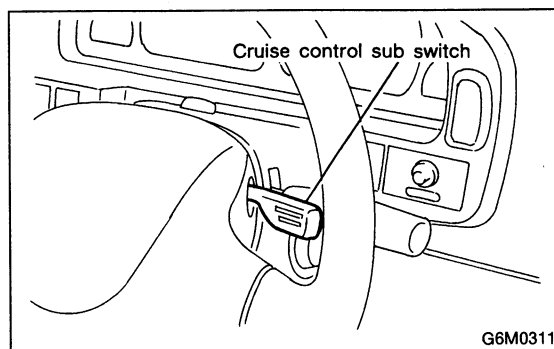

5. CRUISE CONTROL SUB SWITCH

- 1) Remove horn pad and disconnect horn switch connector.
- 2) Remove attaching screws and then, remove cruise control sub switch.

C: DRIVING TESTS

Conduct road tests by selecting a smooth, flat road or use free rollers as road test simulation.

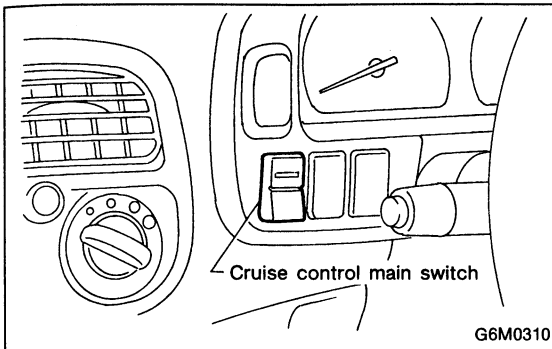
**1. CRUISE CONTROL MAIN SWITCH**

- 1) Turn ignition switch to ON.
- 2) Check that indicator light comes on when main switch is pressed (ON).
- 3) Check that indicator light goes out when main switch is pressed again (OFF).
- 4) Turn ignition switch to OFF with main switch ON (which is indicated by illumination). Turn ignition switch to ON again to ensure that indicator light remains OFF.

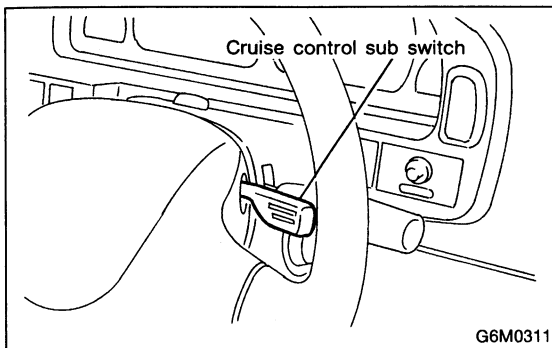
**2. CRUISE CONTROL SUB SWITCH**

- 1) Check that sub switch is properly set in "SET/ COAST" or "RESUME/ACCEL" mode.
- 2) Also check that sub switch returns to the original position when released.

3. CONSTANT SPEED TEST

- 1) Turn cruise control main switch to ON.
- 2) Drive vehicle at speed greater than 40 km/h (25 MPH).
- 3) Press sub switch to set in "SET/COAST" mode.
- 4) Ensure that vehicle is maintained at the speed set when sub switch was pressed.

4. ACCELERATION TEST

- 1) Set vehicle speed at speed greater than 35 km/h (22 MPH).
- 2) Ensure that vehicle continues to accelerate while holding sub switch in "RESUME/ACCEL" mode, and that vehicle maintains that optional speed when sub switch is released.

5. DECELERATION TEST

- 1) Set vehicle speed at optional speed greater than 40 km/h (25 MPH).
- 2) Ensure that vehicle continues to decelerate while holding sub switch in "SET/COAST" mode, and that it maintains that optional speed when sub switch is released.

NOTE:

When vehicle speed reaches the lower speed limit of 30 km/h (19 MPH) during deceleration, cruise control will be released.

12. Vehicle Speed Sensor 2 (Turbo model)

A: DESCRIPTION

1. MECHANISM

The vehicle speed sensor is a rotating type that utilizes a magnetic resistance element MRE. The MRE is a two-dimensional magnetic sensor whose resistance value varies with changes in the direction of the magnetic field. When the multi-pole ring magnet built into the sensor rotates along with the revolution of the transmission's driven gear, the direction of the magnetic field applied to the MRE cyclically changes by the same number of magnet poles, causing a cyclical change in the resistance value of the MRE. This change in the resistance value is shaped to a rectangular waveform through a built-in IC which produces it as a pulse output.

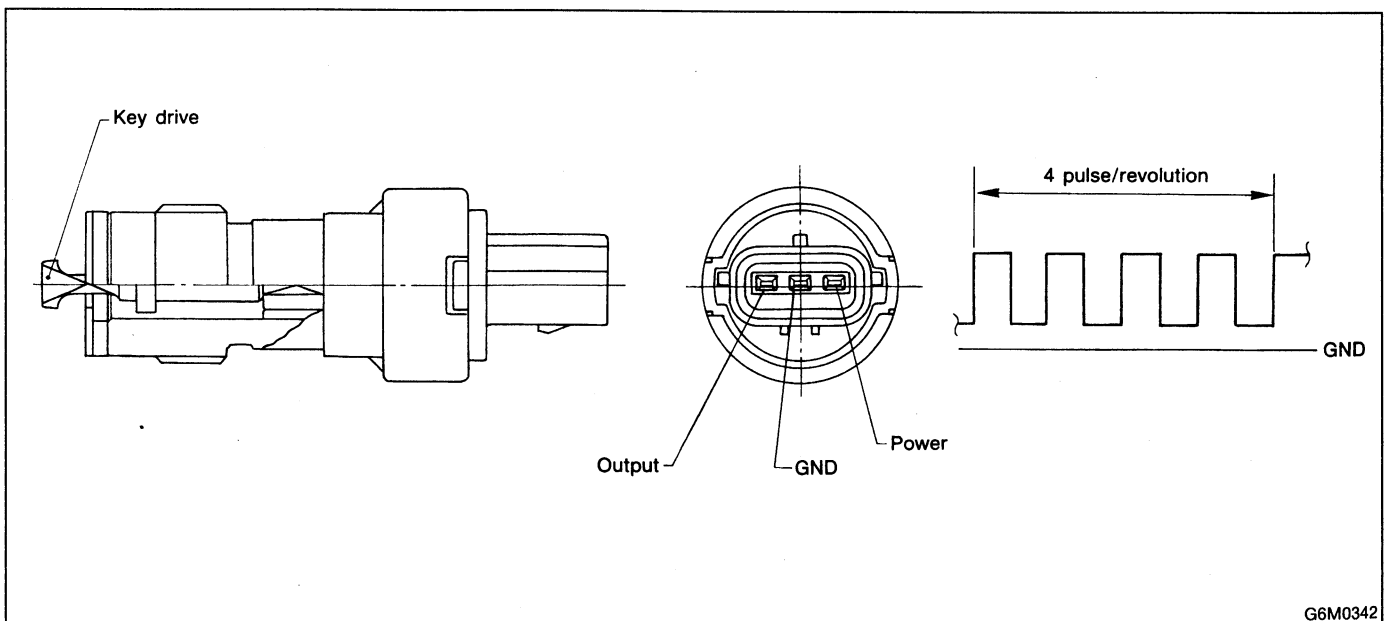

2. GENERAL PRECAUTIONS

- 1) Be careful not to drop or bump sensor as this may break built-in magnet.
- 2) Drive key is designed to separate from vehicle speed sensor. Be careful not to lose it or forget to install.
- 3) Vehicle speed sensor is installed in part (which contains bearings, etc., finished to a high degree of accuracy). Do not allow foreign matter (filings, sand, etc.) to get into it.
- 4) When checking output of vehicle speed sensor as a single unit, ensure test leads are connected to their correct terminals. Failure to do this may damage internal IC.
- 5) Discard vehicle speed sensor after removal; replace with new one.

B: REMOVAL

CAUTION:

- Be careful when removing vehicle speed sensor immediately after driving vehicle for a while as temperature around it is high.
- Before removing vehicle speed sensor, clean dirt, etc. from surrounding areas. Take care not to allow foreign matter to get into mounting hole.

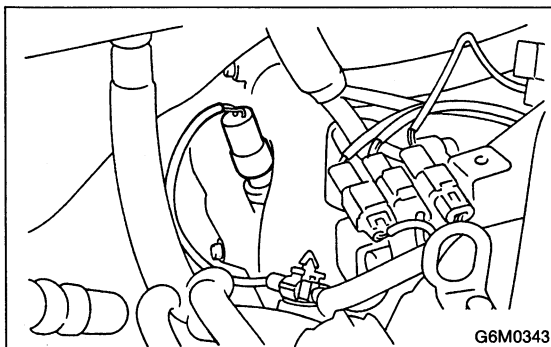

- 1) Remove collector cover.
- 2) Disconnect vehicle speed sensor connector.
- 3) Turn and remove vehicle speed sensor.
- 4) Remove key and packing.

C: INSTALLATION**CAUTION:**

- Ensure sensor mounting hole is clean and free of foreign matter.
- Apply grease to tip end of key to prevent key from falling off sensor.
- Align tip end of key with key groove on end of speedometer shaft during installation.

1) Hand tighten vehicle speed sensor 2, then tighten it using suitable tool.

Tightening torque required for sensor to reach bottom of transmission is as follows.

Tightening torque:

0.39 — 0.88 N·m (4.0 — 9.0 kg-cm, 3.5 — 7.8 in-lb)

CAUTION:

- When torque must be applied that exceeds 0.88 N·m (9.0 kg-cm, 7.8 in-lb), the key and key groove on end of speedometer may not be aligned properly. Remove the key, align it correctly and reassemble.

- Sensor threads are secured by Locktite. The reassembly must be completed within 5 minutes before Locktite dries.

2) Tighten vehicle speed sensor 2 further to specified torque.

Tightening torque:

5.9 ± 1.5 N·m (60 ± 15 kg-cm, 52 ± 13 in-lb)